



## Device Overview

The 89HPES12N3A is a member of the IDT PRECISE™ family of PCI Express® switching solutions. The PES12N3A is a 12-lane, 3-port peripheral chip that performs PCI Express packet switching with a feature set optimized for high performance applications such as servers, storage, and communications/networking. It provides connectivity and switching functions between a PCI Express upstream port and two downstream ports and supports switching between downstream ports.

## Features

- ◆ **High Performance PCI Express Switch**
  - Twelve 2.5Gbps PCI Express lanes
  - Three switch ports
  - Upstream port configurable up to x4
  - Downstream ports configurable up to x4
  - Low-latency cut-through switch architecture
  - Support for Max Payload Sizes up to 2048 bytes
  - One virtual channel
  - Eight traffic classes
  - PCI Express Base Specification Revision 1.1 compliant
- ◆ **Flexible Architecture with Numerous Configuration Options**
  - Automatic per port link width negotiation to x4, x2 or x1
  - Automatic lane reversal on all ports
  - Automatic polarity inversion on all lanes
  - Ability to load device configuration from serial EEPROM
- ◆ **Legacy Support**
  - PCI compatible INTx emulation
  - Bus locking
- ◆ **Highly Integrated Solution**
  - Requires no external components
  - Incorporates on-chip internal memory for packet buffering and queuing
  - Integrates twelve 2.5 Gbps embedded SerDes with 8B/10B encoder/decoder (no separate transceivers needed)
- ◆ **Reliability, Availability, and Serviceability (RAS) Features**
  - Supports ECRC and Advanced Error Reporting
  - Internal end-to-end parity protection on all TLPs ensures data integrity even in systems that do not implement end-to-end CRC (ECRC)
  - Supports PCI Express Native Hot-Plug, Hot-Swap capable I/O
  - Compatible with Hot-Plug I/O expanders used on PC and server motherboards

## Block Diagram

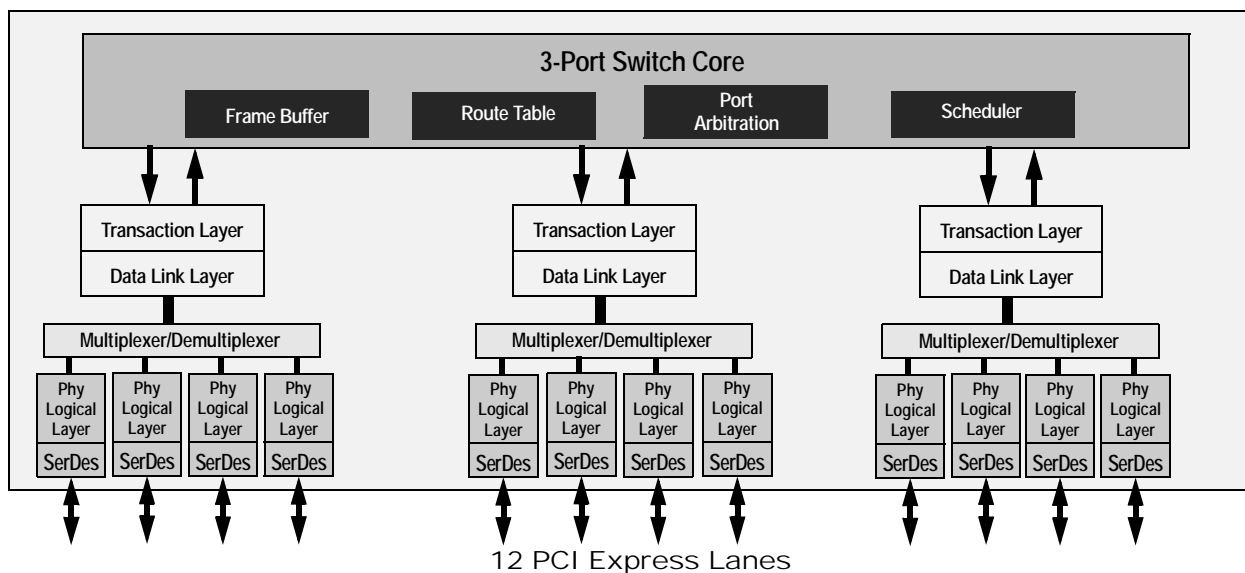

Figure 1 Internal Block Diagram

- ◆ **Power Management**
  - Utilizes advanced low-power design techniques to achieve low typical power consumption
  - Supports PCI Power Management Interface specification (PCI-PM 1.1)
    - Supports device power management states: D0, D3<sub>hot</sub> and D3<sub>cold</sub>
  - Unused SerDes are disabled
- ◆ **Testability and Debug Features**
  - Ability to read and write any internal register via the SMBus
- ◆ **Eight General Purpose Input/Output Pins**
  - Each pin may be individually configured as an input or output
  - Each pin may be individually configured as an interrupt input
  - Some pins have selectable alternate functions
- ◆ **Packaged in 19x19mm 324-ball BGA with 1mm ball spacing**

**Product Description**

Utilizing standard PCI Express interconnect, the PES12N3A provides the most efficient I/O connectivity solution for applications requiring high throughput, low latency, and simple board layout with a minimum number of board layers. It provides 6 GBps (48 Gbps) of aggregated, full-duplex switching capacity through 12 integrated serial lanes, using proven and robust IDT technology. Each lane provides 2.5 Gbps of bandwidth in both directions and is fully compliant with PCI Express Base specification revision 1.1.

**SMBus Interface**

The PES12N3A contains two SMBus interfaces. The slave interface provides full access to the configuration registers in the PES12N3A, allowing every configuration register in the device to be read or written by an external agent. The master interface allows the default configuration register values of the PES12N3A to be overridden following a reset with values programmed in an external serial EEPROM. The master interface is also used by an external Hot-Plug I/O expander.

Six pins make up each of the two SMBus interfaces. These pins consist of an SMBus clock pin, an SMBus data pin, and 4 SMBus address pins. In the slave interface, these address pins allow the SMBus address to which the device responds to be configured. In the master interface, these address pins allow the SMBus address of the serial configuration EEPROM from which data is loaded to be configured. The SMBus address is set up on negation of PERSTN by sampling the corresponding address pins. When the pins are sampled, the resulting address is assigned as shown in Table 1.

Bit	Slave SMBus Address	Master SMBus Address
1	SSMBADDR[1]	MSMBADDR[1]
2	SSMBADDR[2]	MSMBADDR[2]

Table 1 Master and Slave SMBus Address Assignment

Bit	Slave SMBus Address	Master SMBus Address
3	SSMBADDR[3]	MSMBADDR[3]
4	0	MSMBADDR[4]
5	SSMBADDR[5]	1
6	1	0
7	1	1

Table 1 Master and Slave SMBus Address Assignment

As shown in Figure 2, the master and slave SMBuses may be used in a unified or split configuration. In the unified configuration, shown in Figure 2(a), the master and slave SMBuses are tied together and the PES12N3A acts both as a SMBus master as well as a SMBus slave on this bus. This requires that the SMBus master or processor that has access to PES12N3A registers supports SMBus arbitration. In some systems, this SMBus master interface may be implemented using general purpose I/O pins on a processor or micro controller, and may not support SMBus arbitration. To support these systems, the PES12N3A may be configured to operate in a split configuration as shown in Figure 2(b).

In the split configuration, the master and slave SMBuses operate as two independent buses and thus multi-master arbitration is never required. The PES12N3A supports reading and writing of the serial EEPROM on the master SMBus via the slave SMBus, allowing in system programming of the serial EEPROM.

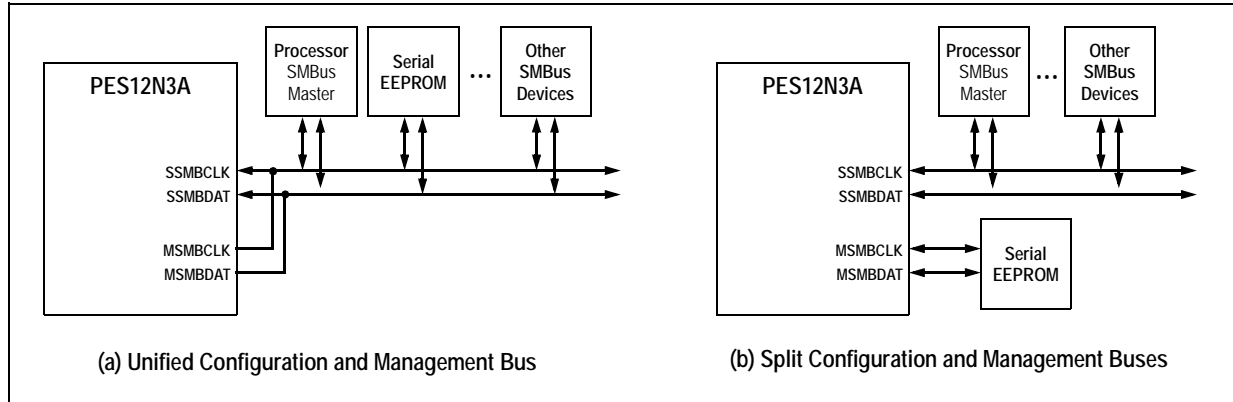

Figure 2 SMBus Interface Configuration Examples

### Hot-Plug Interface

The PES12N3A supports PCI Express Hot-Plug on each downstream port. To reduce the number of pins required on the device, the PES12N3A utilizes an external I/O expander, such as that used on PC motherboards, connected to the SMBus master interface. Following reset and configuration, whenever the state of a Hot-Plug output needs to be modified, the PES12N3A generates an SMBus transaction to the I/O expander with the new value of all of the outputs. Whenever a Hot-Plug input changes, the I/O expander generates an interrupt which is received on the IOEXPINTN input pin (alternate function of GPIO) of the PES12N3A. In response to an I/O expander interrupt, the PES12N3A generates an SMBus transaction to read the state of all of the Hot-Plug inputs from the I/O expander.

### General Purpose Input/Output

The PES12N3A provides eight General Purpose Input/Output (GPIO) pins that may be used by the system designer as bit I/O ports. Each GPIO pin may be configured independently as an input or output through software control. Some GPIO pins are shared with other on-chip functions. These alternate functions may be enabled via software, SMBus slave interface, or serial configuration EEPROM.

The PES12N3A is based on a flexible and efficient layered architecture. The PCI Express layer consists of SerDes, Physical, Data Link and Transaction layers in compliance with PCI Express Base specification Revision 1.1. The PES12N3A can operate either as a store and forward or cut-through switch and is designed to switch memory and I/O transactions. It supports eight Traffic Classes (TCs) and one Virtual Channel (VC) with sophisticated resource management to enable efficient switching and I/O connectivity for servers, storage, and embedded applications.

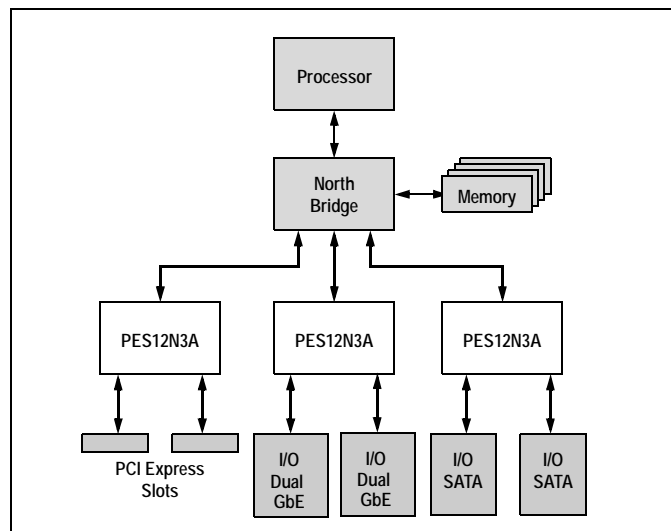

Figure 3 I/O Expansion Application

## Pin Description

The following tables list the functions of the pins provided on the PES12N3A. Some of the functions listed may be multiplexed onto the same pin. The active polarity of a signal is defined using a suffix. Signals ending with an "N" are defined as being active, or asserted, when at a logic zero (low) level. All other signals (including clocks, buses, and select lines) will be interpreted as being active, or asserted, when at a logic one (high) level.

**Note:** In the PES12N3A, the two downstream ports are labeled port 2 and port 4.

Signal	Type	Name/Description
PE0RP[3:0] PE0RN[3:0]	I	<b>PCI Express Port 0 Serial Data Receive.</b> Differential PCI Express receive pairs for port 0.
PE0TP[3:0] PE0TN[3:0]	O	<b>PCI Express Port 0 Serial Data Transmit.</b> Differential PCI Express transmit pairs for port 0.
PE2RP[3:0] PE2RN[3:0]	I	<b>PCI Express Port 2 Serial Data Receive.</b> Differential PCI Express receive pairs for port 2.
PE2TP[3:0] PE2TN[3:0]	O	<b>PCI Express Port 2 Serial Data Transmit.</b> Differential PCI Express transmit pairs for port 2.
PE4RP[3:0] PE4RN[3:0]	I	<b>PCI Express Port 4 Serial Data Receive.</b> Differential PCI Express receive pairs for port 4.
PE4TP[3:0] PE4TN[3:0]	O	<b>PCI Express Port 4 Serial Data Transmit.</b> Differential PCI Express transmit pairs for port 4.
PEREFCLKP[2:1] PEREFCLKN[2:1]	I	<b>PCI Express Reference Clock.</b> Differential reference clock pair input. This clock is used as the reference clock by on-chip PLLs to generate the clocks required for the system logic and on-chip SerDes. The frequency of the differential reference clock is determined by the REFCLKM signal.
REFCLKM	I	<b>PCI Express Reference Clock Mode Select.</b> This signal selects the frequency of the reference clock input. 0x0 - 100 MHz 0x1 - 125 MHz

Table 2 PCI Express Interface Pins

Signal	Type	Name/Description
MSMBADDR[4:1]	I	<b>Master SMBus Address.</b> These pins determine the SMBus address of the serial EEPROM from which configuration information is loaded.
MSMBCLK	I/O	<b>Master SMBus Clock.</b> This bidirectional signal is used to synchronize transfers on the master SMBus. It is active and generating the clock only when the EEPROM or I/O Expanders are being accessed.
MSMBDAT	I/O	<b>Master SMBus Data.</b> This bidirectional signal is used for data on the master SMBus.
SSMBADDR[5:3:1]	I	<b>Slave SMBus Address.</b> These pins determine the SMBus address to which the slave SMBus interface responds.
SSMBCLK	I/O	<b>Slave SMBus Clock.</b> This bidirectional signal is used to synchronize transfers on the slave SMBus.
SSMBDAT	I/O	<b>Slave SMBus Data.</b> This bidirectional signal is used for data on the slave SMBus.

Table 3 SMBus Interface Pins

Signal	Type	Name/Description
GPIO[0]	I/O	<b>General Purpose I/O.</b> This pin can be configured as a general purpose I/O pin. Alternate function pin name: P2RSTN Alternate function pin type: Output Alternate function: Reset output for downstream port 2
GPIO[1]	I/O	<b>General Purpose I/O.</b> This pin can be configured as a general purpose I/O pin. Alternate function pin name: P4RSTN Alternate function pin type: Output Alternate function: Reset output for downstream port 4
GPIO[2]	I/O	<b>General Purpose I/O.</b> This pin can be configured as a general purpose I/O pin. Alternate function pin name: IOEXPINTN0 Alternate function pin type: Input Alternate function: I/O Expander interrupt 0 input
GPIO[3]	I/O	<b>General Purpose I/O.</b> This pin can be configured as a general purpose I/O pin.
GPIO[4]	I/O	<b>General Purpose I/O.</b> This pin can be configured as a general purpose I/O pin. Alternate function pin name: IOEXPINTN2 Alternate function pin type: Input Alternate function: I/O Expander interrupt 2 input
GPIO[5]	I/O	<b>General Purpose I/O.</b> This pin can be configured as a general purpose I/O pin.
GPIO[6]	I/O	<b>General Purpose I/O.</b> This pin can be configured as a general purpose I/O pin.
GPIO[7]	I/O	<b>General Purpose I/O.</b> This pin can be configured as a general purpose I/O pin. Alternate function pin name: GPEN Alternate function pin type: Output Alternate function: General Purpose Event (GPE) output

Table 4 General Purpose I/O Pins

Signal	Type	Name/Description
CCLKDS	I	<b>Common Clock Downstream.</b> When the CCLKDS pin is asserted, it indicates that a common clock is being used between the downstream device and the downstream port.
CCLKUS	I	<b>Common Clock Upstream.</b> When the CCLKUS pin is asserted, it indicates that a common clock is being used between the upstream device and the upstream port.
MSMBSMODE	I	<b>Master SMBus Slow Mode.</b> The assertion of this pin indicates that the master SMBus should operate at 100 KHz instead of 400 KHz. This value may not be overridden.

Table 5 System Pins (Part 1 of 2)

Signal	Type	Name/Description
PERSTN	I	<b>Fundamental Reset.</b> Assertion of this signal resets all logic inside the PES12N3A and initiates a PCI Express fundamental reset.
RSTHALT	I	<b>Reset Halt.</b> When this signal is asserted during a PCI Express fundamental reset, the PES12N3A executes the reset procedure and remains in a reset state with the Master and Slave SMBuses active. This allows software to read and write registers internal to the device before normal device operation begins. The device exits the reset state when the RSTHALT bit is cleared in the SWCTL register by an SMBus master.
SWMODE[3:0]	I	<b>Switch Mode.</b> These configuration pins determine the PES12N3A switch operating mode. 0x0 - Normal switch mode 0x1 - Normal switch mode with Serial EEPROM initialization 0x2 - through 0xF Reserved

Table 5 System Pins (Part 2 of 2)

Signal	Type	Name/Description
JTAG_TCK	I	<b>JTAG Clock.</b> This is an input test clock used to clock the shifting of data into or out of the boundary scan logic or JTAG Controller. JTAG_TCK is independent of the system clock with a nominal 50% duty cycle.
JTAG_TDI	I	<b>JTAG Data Input.</b> This is the serial data input to the boundary scan logic or JTAG Controller.
JTAG_TDO	O	<b>JTAG Data Output.</b> This is the serial data shifted out from the boundary scan logic or JTAG Controller. When no data is being shifted out, this signal is tri-stated.
JTAG_TMS	I	<b>JTAG Mode.</b> The value on this signal controls the test mode select of the boundary scan logic or JTAG Controller.
JTAG_TRST_N	I	<b>JTAG Reset.</b> This active low signal asynchronously resets the boundary scan logic and JTAG TAP Controller. An external pull-up on the board is recommended to meet the JTAG specification in cases where the tester can access this signal. However, for systems running in functional mode, one of the following should occur: 1) actively drive this signal low with control logic 2) statically drive this signal low with an external pull-down on the board

Table 6 Test Pins

Signal	Type	Name/Description
V <sub>DD</sub> CORE	I	Core V <sub>DD</sub> . Power supply for core logic.
V <sub>DD</sub> IO	I	I/O V <sub>DD</sub> . LVTTTL I/O buffer power supply.
V <sub>DD</sub> PE	I	PCI Express Digital Power. PCI Express digital power used by the digital power of the SerDes.

Table 7 Power and Ground Pins

Signal	Type	Name/Description
V <sub>DD</sub> APE	I	PCI Express Analog Power. PCI Express analog power used by the PLL and bias generator.
V <sub>TT</sub> PE	I	PCI Express Termination Power.
V <sub>SS</sub>	I	Ground.

Table 7 Power and Ground Pins

## Pin Characteristics

**Note:** Some input pads of the PES12N3A do not contain internal pull-ups or pull-downs. Unused inputs should be tied off to appropriate levels. This is especially critical for unused control signal inputs which, if left floating, could adversely affect operation. Also, any input pin left floating can cause a slight increase in power consumption.

Function	Pin Name	Type	Buffer	I/O Type	Internal Resistor <sup>1</sup>	Notes
PCI Express Interface	PE0RN[3:0]	I	CML	Serial link		
	PE0RP[3:0]	I				
	PE0TN[3:0]	O				
	PE0TP[3:0]	O				
	PE2RN[3:0]	I				
	PE2RP[3:0]	I				
	PE2TN[3:0]	O				
	PE2TP[3:0]	O				
	PE4RN[3:0]	I				
	PE4RP[3:0]	I				
	PE4TN[3:0]	O				
	PE4TP[3:0]	O				
	PEREFCLKN[2:1]	I	LVPECL/ CML	Diff. Clock Input		Refer to Table 9
PEREFCLKP[2:1]	I					
	REFCLKM	I	LVTTTL	Input	pull-down	
SMBus	MSMBADDR[4:1]	I	LVTTTL	Input	pull-up	
	MSMBCLK	I/O		STI <sup>2</sup>		pull-up on board
	MSMBDAT	I/O		STI		pull-up on board
	SSMBADDR[5,3:1]	I		Input	pull-up	
	SSMBCLK	I/O		STI		pull-up on board
	SSMBDAT	I/O		STI		pull-up on board
General Purpose I/O	GPIO[7:0]	I/O	LVTTTL	High Drive	pull-up	
System Pins	CCLKDS	I	LVTTTL	Input	pull-up	
	CCLKUS	I			pull-up	
	MSMBSMODE	I			pull-down	
	PERSTN	I				
	RSTHALT	I			pull-down	
	SWMODE[3:0]	I			pull-down	

Table 8 Pin Characteristics (Part 1 of 2)

Function	Pin Name	Type	Buffer	I/O Type	Internal Resistor <sup>1</sup>	Notes
JTAG	JTAG_TCK	I	LVTTTL	STI	pull-up	
	JTAG_TDI	I		STI	pull-up	
	JTAG_TDO	O				
	JTAG_TMS	I		STI	pull-up	
	JTAG_TRST_N	I		STI	pull-up	External pull-down

Table 8 Pin Characteristics (Part 2 of 2)

<sup>1</sup> Internal resistor values under typical operating conditions are 54K  $\Omega$  for pull-up and 251K  $\Omega$  for pull-down.

<sup>2</sup> Schmitt Trigger Input (STI).

# Logic Diagram — PES12N3A

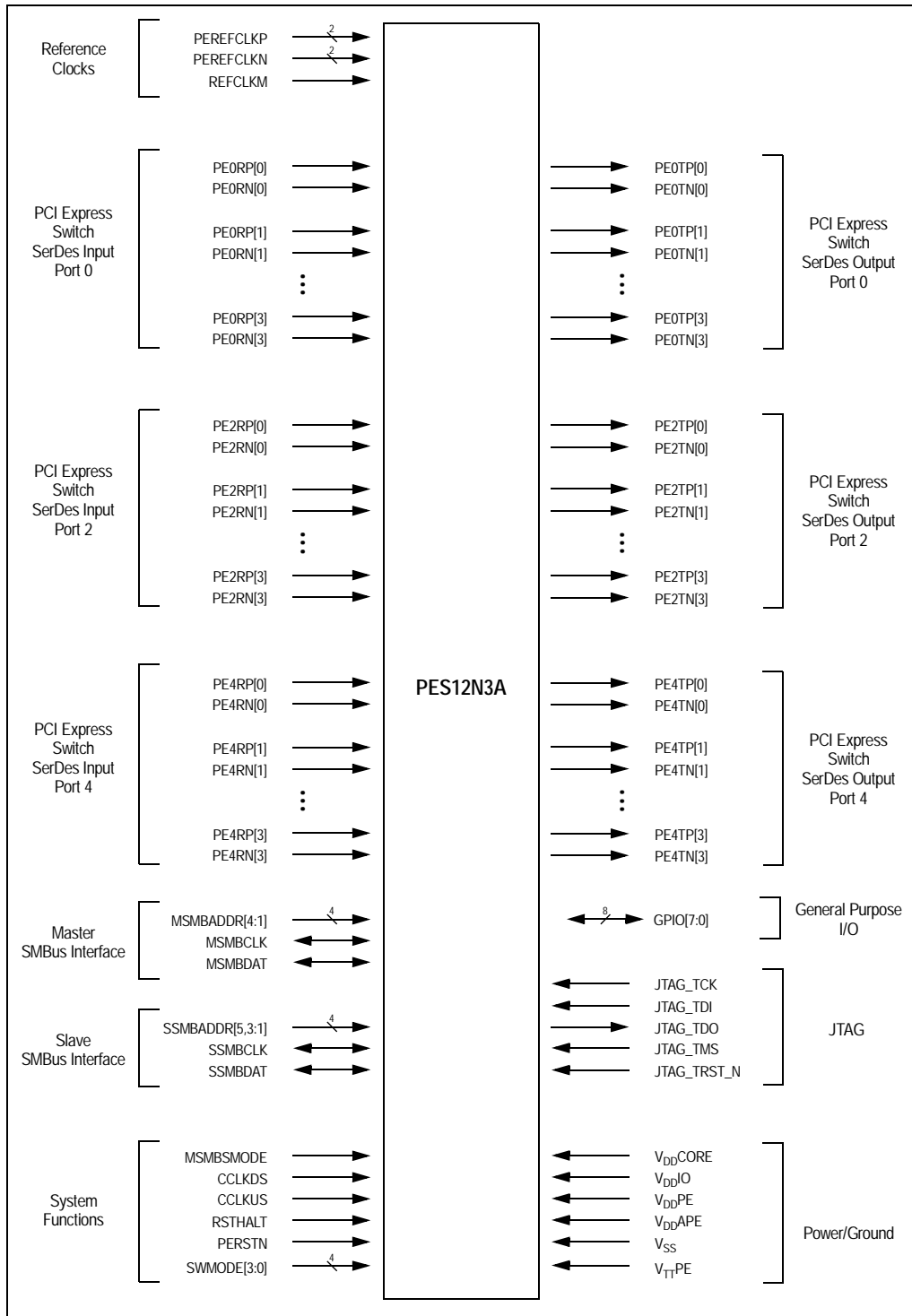

Figure 4 PES12N3A Logic Diagram

## System Clock Parameters

Values based on systems running at recommended supply voltages and operating temperatures, as shown in Tables 13 and 14.

Parameter	Description	Min	Typical	Max	Unit
Refclk <sub>FREQ</sub>	Input reference clock frequency range	100		125 <sup>1</sup>	MHz
Refclk <sub>DC</sub> <sup>2</sup>	Duty cycle of input clock	40	50	60	%
T <sub>R</sub> , T <sub>F</sub>	Rise/Fall time of input clocks			0.2*RCUI	RCUI <sup>3</sup>
V <sub>SW</sub>	Differential input voltage swing <sup>4</sup>	0.6		1.6	V
T <sub>jitter</sub>	Input clock jitter (cycle-to-cycle)			125	ps

**Table 9 Input Clock Requirements**

<sup>1</sup> The input clock frequency will be either 100 or 125 MHz depending on signal REFCLKM.

<sup>2</sup> ClkIn must be AC coupled. Use 0.01 — 0.1 μF ceramic capacitors.

<sup>3</sup> RCUI (Reference Clock Unit Interval) refers to the reference clock period.

<sup>4</sup> AC coupling required.

## AC Timing Characteristics

Parameter	Description	Min <sup>1</sup>	Typical <sup>1</sup>	Max <sup>1</sup>	Units
<b>PCIe Transmit</b>					
UI	Unit Interval	399.88	400	400.12	ps
T <sub>TX-EYE</sub>	Minimum Tx Eye Width	0.7	.9		UI
T <sub>TX-EYE-MEDIAN-to-MAX-JITTER</sub>	Maximum time between the jitter median and maximum deviation from the median			0.15	UI
T <sub>TX-RISE</sub> , T <sub>TX-FALL</sub>	D+ / D- Tx output rise/fall time	50	90		ps
T <sub>TX-IDLE-MIN</sub>	Minimum time in idle	50			UI
T <sub>TX-IDLE-SET-TO-IDLE</sub>	Maximum time to transition to a valid Idle after sending an Idle ordered set			20	UI
T <sub>TX-IDLE-TO-DIFF-DATA</sub>	Maximum time to transition from valid idle to diff data			20	UI
T <sub>TX-SKEW</sub>	Transmitter data skew between any 2 lanes		500	1300	ps
<b>PCIe Receive</b>					
UI	Unit Interval	399.88	400	400.12	ps
T <sub>RX-EYE (with jitter)</sub>	Minimum Receiver Eye Width (jitter tolerance)	0.4			UI
T <sub>RX-EYE-MEDIUM TO MAX JITTER</sub>	Max time between jitter median & max deviation			0.3	UI
T <sub>RX-IDLE-DET-DIFF-ENTER TIME</sub>	Unexpected Idle Enter Detect Threshold Integration Time			10	ms
T <sub>RX-SKEW</sub>	Lane to lane input skew			20	ns

**Table 10 PCIe AC Timing Characteristics**

<sup>1</sup> Minimum, Typical, and Maximum values meet the requirements under PCI Specification 1.1

Signal	Symbol	Reference Edge	Min	Max	Unit	Timing Diagram Reference
<b>GPIO</b>						
GPIO[7:0] <sup>1</sup>	Tpw_13b <sup>2</sup>	None	50	—	ns	

**Table 11 GPIO AC Timing Characteristics**

<sup>1</sup> GPIO signals must meet the setup and hold times if they are synchronous or the minimum pulse width if they are asynchronous.

<sup>2</sup> The values for this symbol were determined by calculation, not by testing.

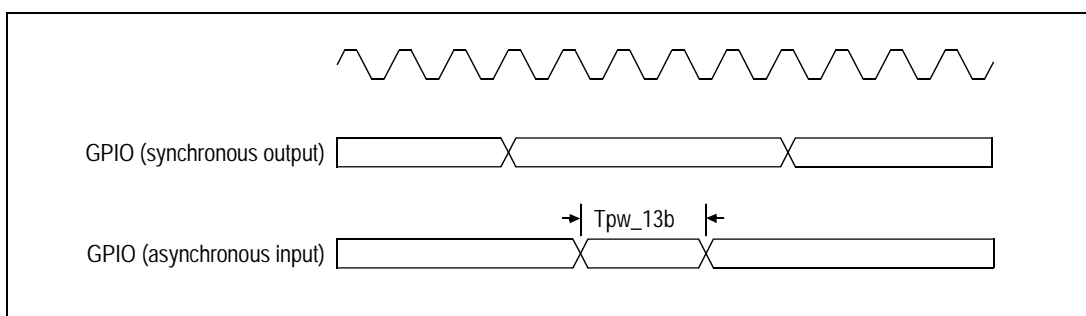

Signal	Symbol	Reference Edge	Min	Max	Unit	Timing Diagram Reference
<b>JTAG</b>						
JTAG_TCK	Tper_16a	none	50.0	—	ns	See Figure 5.
	Thigh_16a, Tlow_16a		10.0	25.0	ns	
JTAG_TMS <sup>1</sup> , JTAG_TDI	Tsu_16b	JTAG_TCK rising	2.4	—	ns	
	Thld_16b		1.0	—	ns	
JTAG_TDO	Tdo_16c	JTAG_TCK falling	—	20	ns	
	Tdz_16c <sup>2</sup>		—	20	ns	
JTAG_TRST_N	Tpw_16d <sup>2</sup>	none	25.0	—	ns	

**Table 12 JTAG AC Timing Characteristics**

<sup>1</sup> The JTAG specification, IEEE 1149.1, recommends that JTAG\_TMS should be held at 1 while the signal applied at JTAG\_TRST\_N changes from 0 to 1. Otherwise, a race may occur if JTAG\_TRST\_N is deasserted (going from low to high) on a rising edge of JTAG\_TCK when JTAG\_TMS is low, because the TAP controller might go to either the Run-Test/Idle state or stay in the Test-Logic-Reset state.

<sup>2</sup> The values for this symbol were determined by calculation, not by testing.

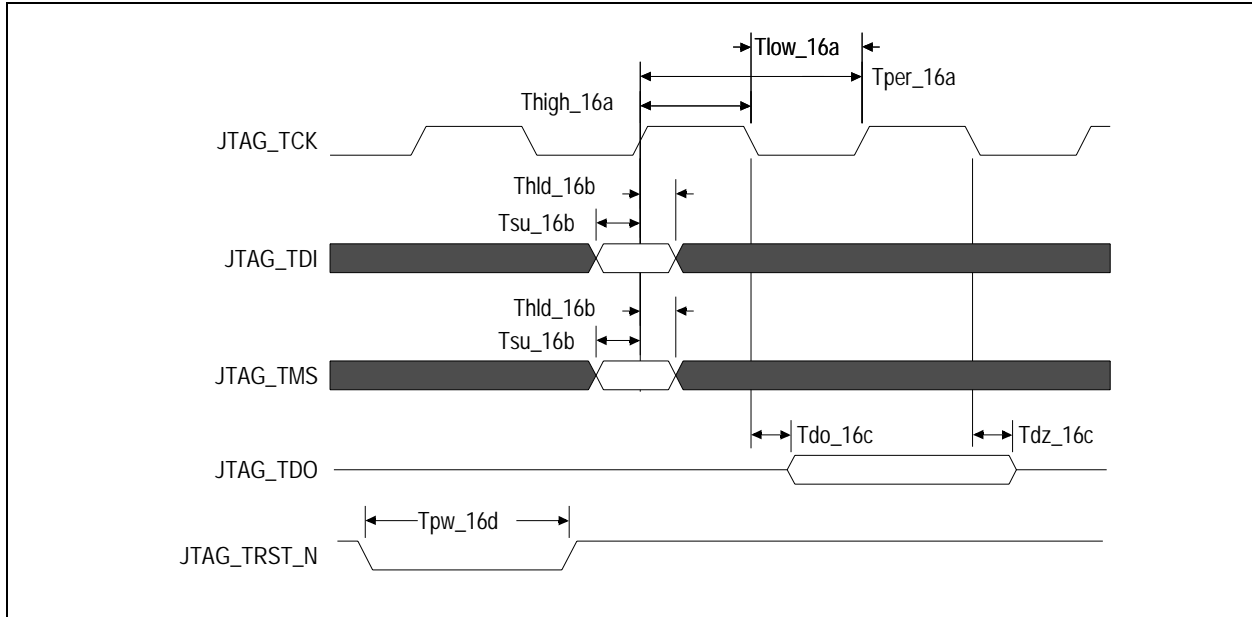

Figure 5 JTAG AC Timing Waveform

## Recommended Operating Supply Voltages

Symbol	Parameter	Minimum	Typical	Maximum	Unit
V <sub>DD</sub> CORE	Internal logic supply	0.9	1.0	1.1	V
V <sub>DD</sub> I/O	I/O supply except for SerDes LVPECL/CML	3.0	3.3	3.6	V
V <sub>DD</sub> PE	PCI Express Digital Power	0.9	1.0	1.1	V
V <sub>DD</sub> APE	PCI Express Analog Power	0.9	1.0	1.1	V
V <sub>TT</sub> PE	PCI Express Serial Data Transmit Termination Voltage	1.425	1.5	1.575	V
V <sub>SS</sub>	Common ground	0	0	0	V

Table 13 PES12N3A Operating Voltages

## Power-Up Sequence

This section describes the sequence in which various voltages must be applied to the part during power-up to ensure proper functionality. For the PES12N3A, the power-up sequence must be as follows:

1. V<sub>DD</sub>I/O — 3.3V
2. V<sub>DD</sub>Core, V<sub>DD</sub>PE, V<sub>DD</sub>APE — 1.0V
3. V<sub>TT</sub>PE — 1.5V

When powering up, each voltage level must ramp and stabilize prior to applying the next voltage in the sequence to ensure internal latch-up issues are avoided. There are no maximum time limitations in ramping to valid power levels. The power-down sequence must be in the reverse order of the power-up sequence.

## Recommended Operating Temperature

Grade	Temperature
Commercial	0°C to +70°C Ambient

Table 14 PES12N3A Operating Temperatures

## Power Consumption

Typical power is measured under the following conditions: 25°C Ambient, 35% total link usage on all ports, typical voltages defined in Table 13 (and also listed below).

Maximum power is measured under the following conditions: 70°C Ambient, 85% total link usage on all ports, maximum voltages defined in Table 13 (and also listed below).

Number of active Lanes per Port		Core Supply		PCIe Digital Supply		PCIe Analog Supply		PCIe Termination Supply		I/O Supply		Total	
		Typ 1.0V	Max 1.1V	Typ 1.0V	Max 1.1V	Typ 1.0V	Max 1.1V	Typ 1.5V	Max 1.575V	Typ 3.3V	Max 3.6V	Typ Power	Max Power
4/4/4	mA	723	928	578	693	223	251	291	345	1	1	1.96W	2.6W
	Watts	0.72	1.02	0.58	0.76	0.22	0.28	0.44	0.54	0.004	0.004		
4/1/1	mA	618	746	398	458	207	223	142	160	1	1	1.44W	1.8W
	Watts	0.62	0.82	0.4	0.5	0.21	0.25	0.21	0.25	0.003	0.003		

Table 15 PES12N3A Power Consumption

## Thermal Considerations

This section describes thermal considerations for the PES12N3A (19mm<sup>2</sup> BCG324 package). The data in Table 16 below contains information that is relevant to the thermal performance of the PES12N3A switch.

Symbol	Parameter	Value	Units	Conditions
$T_{J(max)}$	Junction Temperature	125	°C	Maximum
$T_{A(max)}$	Ambient Temperature	70	°C	Maximum for commercial-rated products
$\theta_{JA(effective)}$	Effective Thermal Resistance, Junction-to-Ambient	11.9	°C/W	Zero air flow
		9.9	°C/W	1 m/S air flow
		9.3	°C/W	2 m/S air flow
P	Power Dissipation of the Device	2.6	Watts	Maximum

Table 16 Thermal Specifications for PES12N3A, 19x19 mm BCG324 Package

**Note:** The parameter  $\theta_{JA(ef)}$  is not the *absolute* thermal resistance for the package as defined by JEDEC (JESD-51). Because resistance can vary with the number of board layers, size of the board, and airflow,  $\theta_{JA(ef)}$  is the *effective* thermal resistance. The values for effective  $\theta_{JA}$  given above are based on a 10-layer, standard height, full length (4.3"x12.2") PCIe add-in card.

## Heat Sink

Table 17 lists heat sink requirements for the PES12N3A under three common usage scenarios. As shown in this table, a heat sink is not required in most cases.

Air Flow	Board Size	Board Layers	Heat Sink Requirement
Zero	4.3"x12.2" (standard height, full length form factor) or larger	4 or more	No heat sink required
Zero	Any	6 or more	No heat sink required
1 m/S or more	Any	Any	No heat sink required

Table 17 Heat Sink Requirements Based on Air Flow and Board Characteristics

## Thermal Usage Examples

The junction-to-ambient thermal resistance is a measure of a device's ability to dissipate heat from the die to its surroundings in the absence of a heat sink. The general formula to determine  $\theta_{JA}$  is:

$$\theta_{JA} = (T_J - T_A)/P$$

Thermal reliability of a device is generally assured when the actual value of  $T_J$  in the specific system environment being considered is less than the maximum  $T_J$  specified for the device. Using an ambient temperature of 70°C and assuming a system with 1m/S airflow, the actual value of  $T_J$  is:

$$T_{J(actual)} = T_A + P * \theta_{JA(eff)} = 70^\circ C + 2.6W * 9.9W/^\circ C = 96^\circ C$$

The actual  $T_J$  of 96°C is well below the maximum  $T_J$  of 125°C specified for the device (shown in Table 16). Therefore, no heat sink is needed in this scenario. The formula is also useful from a system design perspective. It can be used to determine if a heat sink should be added to the device based on some desired value of  $T_J$ . For example, if for reliability purposes the desired  $T_J$  is 100°C, then the maximum allowable  $T_A$  is:

$$T_{A(allowed)} = T_{J(desired)} - (P * \theta_{JA(effective)})$$

$$T_{A(allowed)} = 100^\circ C - (2.6W * 9.9W/^\circ C) = 100^\circ C - 26^\circ C = 74^\circ C$$

An appropriate level of increased air flow and/or a heat sink can be added to achieve this lower ambient temperature. Please contact [ssdhelp@idt.com](mailto:ssdhelp@idt.com) for further assistance.

## DC Electrical Characteristics

Values based on systems running at recommended supply voltages, as shown in Table 13.

Note: See Table 8, Pin Characteristics, for a complete I/O listing.

I/O Type	Parameter	Description	Min <sup>1</sup>	Typ <sup>1</sup>	Max <sup>1</sup>	Unit	Conditions
Serial Link	<b>PCIe Transmit</b>						
	V <sub>TX-DIFFp-p</sub>	Differential peak-to-peak output voltage	800		1200	mV	
	V <sub>TX-DE-RATIO</sub>	De-emphasized differential output voltage	-3		-4	dB	
	V <sub>TX-DC-CM</sub>	DC Common mode voltage	-0.1	1	3.7	V	
	V <sub>TX-CM-ACP</sub>	RMS AC peak common mode output voltage			20	mV	
	V <sub>TX-CM-DC-active-idle-delta</sub>	Abs delta of DC common mode voltage between L0 and idle			100	mV	
	V <sub>TX-CM-DC-line-delta</sub>	Abs delta of DC common mode voltage between D+ and D-			25	mV	
	V <sub>TX-Idle-DiffP</sub>	Electrical idle diff peak output			20	mV	
	V <sub>TX-RCV-Detect</sub>	Voltage change during receiver detection			600	mV	
	RL <sub>TX-DIFF</sub>	Transmitter Differential Return loss	12			dB	
	RL <sub>TX-CM</sub>	Transmitter Common Mode Return loss	6			dB	
	Z <sub>TX-DEFF-DC</sub>	DC Differential TX impedance	80	100	120	Ω	
	Z <sub>OSE</sub>	Single ended TX Impedance	40	50	60	Ω	
	Transmitter Eye Diagram	TX Eye Height (De-emphasized bits)	505	650		mV	
	Transmitter Eye Diagram	TX Eye Height (Transition bits)	800	950		mV	
	<b>PCIe Receive</b>						
	V <sub>RX-DIFFp-p</sub>	Differential input voltage (peak-to-peak)	175		1200	mV	
	V <sub>RX-CM-AC</sub>	Receiver common-mode voltage for AC coupling			150	mV	
	RL <sub>RX-DIFF</sub>	Receiver Differential Return Loss	15			dB	
	RL <sub>RX-CM</sub>	Receiver Common Mode Return Loss	6			dB	
Z <sub>RX-DIFF-DC</sub>	Differential input impedance (DC)	80	100	120	Ω		
Z <sub>RX-COMM-DC</sub>	Single-ended input impedance	40	50	60	Ω		
Z <sub>RX-COMM-HIGH-Z-DC</sub>	Powered down input common mode impedance (DC)	200k	350k		Ω		
V <sub>RX-IDLE-DET-DIFFp-p</sub>	Electrical idle detect threshold	65		175	mV		
<b>PCIe REFCLK</b>							
	C <sub>IN</sub>	Input Capacitance	1.5	—		pF	

Table 18 DC Electrical Characteristics (Part 1 of 2)

I/O Type	Parameter	Description	Min <sup>1</sup>	Typ <sup>1</sup>	Max <sup>1</sup>	Unit	Conditions
<b>Other I/Os</b>							
LOW Drive Output	I <sub>OL</sub>		—	2.5	—	mA	V <sub>OL</sub> = 0.4v
	I <sub>OH</sub>		—	-5.5	—	mA	V <sub>OH</sub> = 1.5V
High Drive Output	I <sub>OL</sub>		—	12.0	—	mA	V <sub>OL</sub> = 0.4v
	I <sub>OH</sub>		—	-20.0	—	mA	V <sub>OH</sub> = 1.5V
Schmitt Trigger Input (STI)	V <sub>IL</sub>		-0.3	—	0.8	V	—
	V <sub>IH</sub>		2.0	—	V <sub>DD</sub> I/O + 0.5	V	—
Input	V <sub>IL</sub>		-0.3	—	0.8	V	—
	V <sub>IH</sub>		2.0	—	V <sub>DD</sub> I/O + 0.5	V	—
Capacitance	C <sub>IN</sub>		—	—	8.5	pF	—
Leakage	Inputs		—	—	± 10	μA	V <sub>DD</sub> I/O (max)
	I/O <sub>LEAK</sub> w/o Pull-ups/downs		—	—	± 10	μA	V <sub>DD</sub> I/O (max)
	I/O <sub>LEAK</sub> WITH Pull-ups/downs		—	—	± 80	μA	V <sub>DD</sub> I/O (max)

Table 18 DC Electrical Characteristics (Part 2 of 2)

<sup>1</sup>: Minimum, Typical, and Maximum values meet the requirements under PCI Specification 1.0a.

## Package Pinout — 324-BGA Signal Pinout for PES12N3A

The following table lists the pin numbers and signal names for the PES12N3A device.

Pin	Function	Alt	Pin	Function	Alt	Pin	Function	Alt	Pin	Function	Alt
A1	V <sub>SS</sub>		E10	V <sub>DD</sub> PE		K1	V <sub>DD</sub> CORE		P10	V <sub>DD</sub> IO	
A2	V <sub>SS</sub>		E11	V <sub>SS</sub>		K2	V <sub>SS</sub>		P11	V <sub>DD</sub> IO	
A3	PE0RP03		E12	V <sub>DD</sub> PE		K3	V <sub>TT</sub> PE		P12	V <sub>DD</sub> IO	
A4	V <sub>DD</sub> CORE		E13	V <sub>SS</sub>		K4	V <sub>DD</sub> CORE		P13	V <sub>DD</sub> IO	
A5	PE0TN03		E14	V <sub>DD</sub> CORE		K5	V <sub>DD</sub> PE		P14	V <sub>DD</sub> IO	
A6	V <sub>DD</sub> CORE		E15	V <sub>DD</sub> APE		K6	V <sub>SS</sub>		P15	V <sub>SS</sub>	
A7	PE0TP02		E16	V <sub>SS</sub>		K7	V <sub>SS</sub>		P16	V <sub>TT</sub> PE	
A8	V <sub>DD</sub> CORE		E17	PE4TP03		K8	V <sub>SS</sub>		P17	V <sub>SS</sub>	
A9	PE0RN02		E18	PE4TN03		K9	V <sub>SS</sub>		P18	V <sub>DD</sub> CORE	
A10	V <sub>DD</sub> CORE		F1	V <sub>DD</sub> CORE		K10	V <sub>SS</sub>		R1	PE2TN03	
A11	PE0RP01		F2	V <sub>SS</sub>		K11	V <sub>SS</sub>		R2	PE2TP03	
A12	V <sub>DD</sub> CORE		F3	V <sub>DD</sub> CORE		K12	V <sub>SS</sub>		R3	V <sub>SS</sub>	
A13	PE0TP01		F4	V <sub>DD</sub> APE		K13	V <sub>SS</sub>		R4	V <sub>DD</sub> IO	
A14	V <sub>DD</sub> CORE		F5	V <sub>SS</sub>		K14	V <sub>SS</sub>		R5	V <sub>SS</sub>	
A15	V <sub>DD</sub> CORE		F6	V <sub>DD</sub> CORE		K15	V <sub>DD</sub> PE		R6	V <sub>DD</sub> CORE	
A16	PE0TN00		F7	V <sub>SS</sub>		K16	V <sub>TT</sub> PE		R7	MSMBDAT	
A17	V <sub>SS</sub>		F8	V <sub>DD</sub> CORE		K17	V <sub>SS</sub>		R8	SSMBADDR_5	
A18	V <sub>SS</sub>		F9	V <sub>SS</sub>		K18	V <sub>DD</sub> CORE		R9	NC	
B1	V <sub>DD</sub> CORE		F10	V <sub>DD</sub> CORE		L1	PE2RN02		R10	SWMODE_2	
B2	V <sub>DD</sub> CORE		F11	V <sub>SS</sub>		L2	PE2RP02		R11	RSTHALT	
B3	PE0RN03		F12	V <sub>SS</sub>		L3	V <sub>SS</sub>		R12	GPIO_04	1
B4	V <sub>SS</sub>		F13	V <sub>DD</sub> PE		L4	V <sub>DD</sub> PE		R13	V <sub>DD</sub> CORE	
B5	PE0TP03		F14	V <sub>SS</sub>		L5	V <sub>SS</sub>		R14	V <sub>SS</sub>	
B6	V <sub>SS</sub>		F15	V <sub>DD</sub> IO		L6	V <sub>DD</sub> CORE		R15	V <sub>DD</sub> IO	
B7	PE0TN02		F16	V <sub>SS</sub>		L7	V <sub>DD</sub> CORE		R16	V <sub>SS</sub>	
B8	V <sub>SS</sub>		F17	V <sub>SS</sub>		L8	V <sub>DD</sub> CORE		R17	PE4TP00	
B9	PE0RP02		F18	V <sub>DD</sub> CORE		L9	V <sub>DD</sub> CORE		R18	PE4TN00	
B10	V <sub>SS</sub>		G1	PE2TP01		L10	V <sub>DD</sub> CORE		T1	V <sub>DD</sub> CORE	
B11	PE0RN01		G2	PE2TN01		L11	V <sub>DD</sub> CORE		T2	V <sub>SS</sub>	
B12	V <sub>SS</sub>		G3	V <sub>SS</sub>		L12	V <sub>DD</sub> CORE		T3	V <sub>SS</sub>	
B13	PE0TN01		G4	V <sub>DD</sub> PE		L13	V <sub>DD</sub> CORE		T4	JTAG_TCK	
B14	V <sub>SS</sub>		G5	V <sub>DD</sub> APE		L14	V <sub>SS</sub>		T5	JTAG_TDO	
B15	V <sub>SS</sub>		G6	V <sub>SS</sub>		L15	V <sub>DD</sub> PE		T6	MSMBADDR_1	
B16	PE0TP00		G7	V <sub>SS</sub>		L16	V <sub>SS</sub>		T7	MSMBCLK	

Table 19 PES12N3A 324-pin Signal Pin-Out (Part 1 of 3)

Pin	Function	Alt	Pin	Function	Alt	Pin	Function	Alt	Pin	Function	Alt
B17	V <sub>DD</sub> CORE		G8	V <sub>DD</sub> IO		L17	PE4RP01		T8	SSMBADDR_2	
B18	V <sub>DD</sub> CORE		G9	V <sub>SS</sub>		L18	PE4RN01		T9	CCLKDS	
C1	PE2RP00		G10	V <sub>DD</sub> IO		M1	V <sub>DD</sub> CORE		T10	SWMODE_1	
C2	PE2RN00		G11	V <sub>SS</sub>		M2	V <sub>SS</sub>		T11	PERSTN	
C3	V <sub>SS</sub>		G12	V <sub>DD</sub> CORE		M3	V <sub>SS</sub>		T12	GPIO_03	
C4	V <sub>DD</sub> CORE		G13	V <sub>SS</sub>		M4	V <sub>DD</sub> APE		T13	GPIO_07	1
C5	V <sub>SS</sub>		G14	V <sub>DD</sub> APE		M5	V <sub>SS</sub>		T14	V <sub>SS</sub>	
C6	V <sub>TT</sub> PE		G15	V <sub>DD</sub> PE		M6	V <sub>DD</sub> CORE		T15	REFCLKM	
C7	V <sub>SS</sub>		G16	V <sub>SS</sub>		M7	V <sub>SS</sub>		T16	V <sub>SS</sub>	
C8	V <sub>TT</sub> PE		G17	PE4TN02		M8	V <sub>SS</sub>		T17	V <sub>SS</sub>	
C9	V <sub>SS</sub>		G18	PE4TP02		M9	V <sub>DD</sub> CORE		T18	V <sub>DD</sub> CORE	
C10	V <sub>TT</sub> PE		H1	V <sub>DD</sub> CORE		M10	V <sub>DD</sub> CORE		U1	PE2RP03	
C11	V <sub>SS</sub>		H2	V <sub>SS</sub>		M11	V <sub>SS</sub>		U2	PE2RN03	
C12	V <sub>TT</sub> PE		H3	V <sub>TT</sub> PE		M12	V <sub>SS</sub>		U3	V <sub>SS</sub>	
C13	V <sub>DD</sub> CORE		H4	V <sub>DD</sub> APE		M13	V <sub>DD</sub> CORE		U4	JTAG_TDI	
C14	PE0RP00		H5	V <sub>SS</sub>		M14	V <sub>SS</sub>		U5	JTAG_TMS	
C15	PE0RN00		H6	V <sub>SS</sub>		M15	V <sub>DD</sub> APE		U6	MSMBADDR_2	
C16	V <sub>DD</sub> CORE		H7	V <sub>DD</sub> CORE		M16	V <sub>SS</sub>		U7	MSMBADDR_4	
C17	PE4RN03		H8	V <sub>SS</sub>		M17	V <sub>SS</sub>		U8	SSMBADDR_3	
C18	PE4RP03		H9	V <sub>DD</sub> CORE		M18	V <sub>DD</sub> CORE		U9	CCLKUS	
D1	V <sub>DD</sub> CORE		H10	V <sub>DD</sub> CORE		N1	PE2TP02		U10	SWMODE_0	
D2	V <sub>SS</sub>		H11	V <sub>SS</sub>		N2	PE2TN02		U11	NC	
D3	V <sub>SS</sub>		H12	V <sub>DD</sub> CORE		N3	V <sub>TT</sub> PE		U12	GPIO_00	1
D4	V <sub>DD</sub> CORE		H13	V <sub>SS</sub>		N4	V <sub>DD</sub> APE		U13	GPIO_02	1
D5	V <sub>SS</sub>		H14	V <sub>DD</sub> APE		N5	V <sub>SS</sub>		U14	GPIO_06	
D6	V <sub>DD</sub> APE		H15	V <sub>DD</sub> PE		N6	V <sub>SS</sub>		U15	MSMBSMODE	
D7	V <sub>SS</sub>		H16	V <sub>TT</sub> PE		N7	V <sub>SS</sub>		U16	V <sub>SS</sub>	
D8	V <sub>DD</sub> APE		H17	V <sub>SS</sub>		N8	V <sub>SS</sub>		U17	PE4RN00	
D9	V <sub>SS</sub>		H18	V <sub>DD</sub> CORE		N9	V <sub>SS</sub>		U18	PE4RP00	
D10	V <sub>DD</sub> APE		J1	PE2RP01		N10	V <sub>SS</sub>		V1	V <sub>DD</sub> CORE	
D11	V <sub>SS</sub>		J2	PE2RN01		N11	V <sub>SS</sub>		V2	V <sub>SS</sub>	
D12	V <sub>DD</sub> APE		J3	V <sub>SS</sub>		N12	V <sub>SS</sub>		V3	PEREFCLKP1	
D13	V <sub>SS</sub>		J4	V <sub>DD</sub> PE		N13	V <sub>SS</sub>		V4	PEREFCLKN1	
D14	V <sub>DD</sub> CORE		J5	V <sub>SS</sub>		N14	V <sub>SS</sub>		V5	JTAG_TRST_N	
D15	V <sub>SS</sub>		J6	V <sub>DD</sub> CORE		N15	V <sub>DD</sub> APE		V6	MSMBADDR_3	
D16	V <sub>SS</sub>		J7	V <sub>SS</sub>		N16	V <sub>TT</sub> PE		V7	SSMBADDR_1	
D17	V <sub>SS</sub>		J8	V <sub>SS</sub>		N17	PE4TN01		V8	SSMBCLK	

Table 19 PES12N3A 324-pin Signal Pin-Out (Part 2 of 3)

Pin	Function	Alt	Pin	Function	Alt	Pin	Function	Alt	Pin	Function	Alt
D18	V <sub>DD</sub> CORE		J9	V <sub>DD</sub> CORE		N18	PE4TP01		V9	SSMBDAT	
E1	PE2TN00		J10	V <sub>DD</sub> CORE		P1	V <sub>DD</sub> CORE		V10	NC	
E2	PE2TP00		J11	V <sub>SS</sub>		P2	V <sub>SS</sub>		V11	SWMODE_3	
E3	V <sub>DD</sub> CORE		J12	V <sub>SS</sub>		P3	V <sub>TT</sub> PE		V12	V <sub>DD</sub> IO	
E4	V <sub>SS</sub>		J13	V <sub>DD</sub> CORE		P4	V <sub>SS</sub>		V13	GPIO_01	1
E5	V <sub>DD</sub> CORE		J14	V <sub>SS</sub>		P5	V <sub>DD</sub> IO		V14	GPIO_05	
E6	V <sub>SS</sub>		J15	V <sub>DD</sub> CORE		P6	V <sub>DD</sub> IO		V15	PEREFCLKP2	
E7	V <sub>SS</sub>		J16	V <sub>SS</sub>		P7	V <sub>DD</sub> IO		V16	PEREFCLKN2	
E8	V <sub>DD</sub> PE		J17	PE4RP02		P8	V <sub>DD</sub> IO		V17	V <sub>SS</sub>	
E9	V <sub>SS</sub>		J18	PE4RN02		P9	V <sub>DD</sub> IO		V18	V <sub>DD</sub> CORE	

Table 19 PES12N3A 324-pin Signal Pin-Out (Part 3 of 3)

### Alternate Signal Functions

Pin	GPIO	Alternate
U12	GPIO_00	P2RSTN
V13	GPIO_01	P4RSTN
U13	GPIO_02	IOEXPINTN0
R12	GPIO_04	IOEXPINTN2
T13	GPIO_07	GPEN

Table 20 PES12N3A Alternate Signal Functions

Power Pins

V <sub>DD</sub> Core	V <sub>DD</sub> Core	V <sub>DD</sub> Core	V <sub>DD</sub> IO	V <sub>DD</sub> PE	V <sub>DD</sub> APE	V <sub>TT</sub> PE
A4	F3	L8	F15	E8	D6	C6
A6	F6	L9	G8	E10	D8	C8
A8	F8	L10	G10	E12	D10	C10
A10	F10	L11	P5	F13	D12	C12
A12	F18	L12	P6	G4	E15	H3
A14	G12	L13	P7	G15	F4	H16
A15	H1	M1	P8	H15	G5	K3
B1	H7	M6	P9	J4	G14	K16
B2	H9	M9	P10	K5	H4	N3
B17	H10	M10	P11	K15	H14	N16
B18	H12	M13	P12	L4	M4	P3
C4	H18	M18	P13	L15	M15	P16
C13	J6	P1	P14		N4	
C16	J9	P18	R4		N15	
D1	J10	R6	R15			
D4	J13	R13	V12			
D14	J15	T1				
D18	K1	T18				
E3	K4	V1				
E5	K18	V18				
E14	L6					
F1	L7					

Table 21 PES12N3A Power Pins

## Ground Pins

V <sub>SS</sub>	V <sub>SS</sub>	V <sub>SS</sub>	V <sub>SS</sub>	V <sub>SS</sub>
A1	D15	G11	K10	N8
A2	D16	G13	K11	N9
A17	D17	G16	K12	N10
A18	E4	H2	K13	N11
B4	E6	H5	K14	N12
B6	E7	H6	K17	N13
B8	E9	H8	L3	N14
B10	E11	H11	L5	P2
B12	E13	H13	L14	P4
B14	E16	H17	L16	P15
B15	F2	J3	M2	P17
C3	F5	J5	M3	R3
C5	F7	J7	M5	R5
C7	F9	J8	M7	R14
C9	F11	J11	M8	R16
C11	F12	J12	M11	T2
D2	F14	J14	M12	T3
D3	F16	J16	M14	T14
D5	F17	K2	M16	T16
D7	G3	K6	M17	T17
D9	G6	K7	N5	U3
D11	G7	K8	N6	U16
D13	G9	K9	N7	V2
				V17

Table 22 PES12N3A Ground Pins

## Signals Listed Alphabetically

Signal Name	I/O Type	Location	Signal Category	
CCLKDS	I	T9	System	
CCLKUS	I	U9		
GPIO_00	I/O	U12	General Purpose Input/Output	
GPIO_01	I/O	V13		
GPIO_02	I/O	U13		
GPIO_03	I/O	T12		
GPIO_04	I/O	R12		
GPIO_05	I/O	V14		
GPIO_06	I/O	U14		
GPIO_07	I/O	T13		
JTAG_TCK	I	T4		JTAG
JTAG_TDI	I	U4		
JTAG_TDO	O	T5		
JTAG_TMS	I	U5		
JTAG_TRST_N	I	V5		
MSMBADDR_1	I	T6	SMBus	
MSMBADDR_2	I	U6		
MSMBADDR_3	I	V6		
MSMBADDR_4	I	U7		
MSMBCLK	I/O	T7		
MSMBDAT	I/O	R7		
MSMBSMODE	I	U15	System	
NC		R9	PCI Express	
NC		U11		
NC		V10		
PE0RN00	I	C15		
PE0RN01	I	B11		
PE0RN02	I	A9		
PE0RN03	I	B3		
PE0RP00	I	C14		
PE0RP01	I	A11		
PE0RP02	I	B9		
PE0RP03	I	A3		
PE0TN00	O	A16		

Table 23 PES12N3A Alphabetical Signal List (Part 1 of 3)

Signal Name	I/O Type	Location	Signal Category
PE0TN01	O	B13	PCI Express (cont.)
PE0TN02	O	B7	
PE0TN03	O	A5	
PE0TP00	O	B16	
PE0TP01	O	A13	
PE0TP02	O	A7	
PE0TP03	O	B5	
PE2RN00	I	C2	
PE2RN01	I	J2	
PE2RN02	I	L1	
PE2RN03	I	U2	
PE2RP00	I	C1	
PE2RP01	I	J1	
PE2RP02	I	L2	
PE2RP03	I	U1	
PE2TN00	O	E1	
PE2TN01	O	G2	
PE2TN02	O	N2	
PE2TN03	O	R1	
PE2TP00	O	E2	
PE2TP01	O	G1	
PE2TP02	O	N1	
PE2TP03	O	R2	
PE4RN00	I	U17	
PE4RN01	I	L18	
PE4RN02	I	J18	
PE4RN03	I	C17	
PE4RP00	I	U18	
PE4RP01	I	L17	
PE4RP02	I	J17	
PE4RP03	I	C18	
PE4TN00	O	R18	
PE4TN01	O	N17	
PE4TN02	O	G17	
PE4TN03	O	E18	
PE4TP00	O	R17	

Table 23 PES12N3A Alphabetical Signal List (Part 2 of 3)

Signal Name	I/O Type	Location	Signal Category
PE4TP01	O	N18	PCI Express (cont.)
PE4TP02	O	G18	
PE4TP03	O	E17	
PEREFCLKN1	I	V4	
PEREFCLKN2	I	V16	
PEREFCLKP1	I	V3	
PEREFCLKP2	I	V15	
PERSTN	I	T11	System
REFCLKM	I	T15	PCI Express
RSTHALT	I	R11	System
SSMBADDR_1	I	V7	SMBus
SSMBADDR_2	I	T8	
SSMBADDR_3	I	U8	
SSMBADDR_5	I	R8	
SSMBCLK	I/O	V8	SMBus
SSMBDAT	I/O	V9	
SWMODE_0	I	U10	System
SWMODE_1	I	T10	
SWMODE_2	I	R10	
SWMODE_3	I	V11	
V <sub>DD</sub> CORE, V <sub>DD</sub> APE, V <sub>DD</sub> IO, V <sub>DD</sub> PE, V <sub>TT</sub> PE	See Table 21 for a listing of power pins.		
V <sub>SS</sub>	See Table 22 for a listing of ground pins.		

Table 23 PES12N3A Alphabetical Signal List (Part 3 of 3)

# PES12N3A Pinout — Top View

	1	2	3	4	5	6	7	8	9	10	11	12	13	14	15	16	17	18
A																		
B																		
C																		
D																		
E																		
F																		
G																		
H																		
J																		
K																		
L																		
M																		
N																		
P																		
R																		
T																		
U																		
V																		

	$V_{DD}Core$ (Power)		$V_{TTPE}$ (Power)		Vss (Ground)		Signals
	$V_{DD}I/O$ (Power)		$V_{DDPE}$ (Power)				No Connection
			$V_{DDAPE}$ (Power)				

# PES12N3A Package Drawing — 324-Pin BC324/BCG324

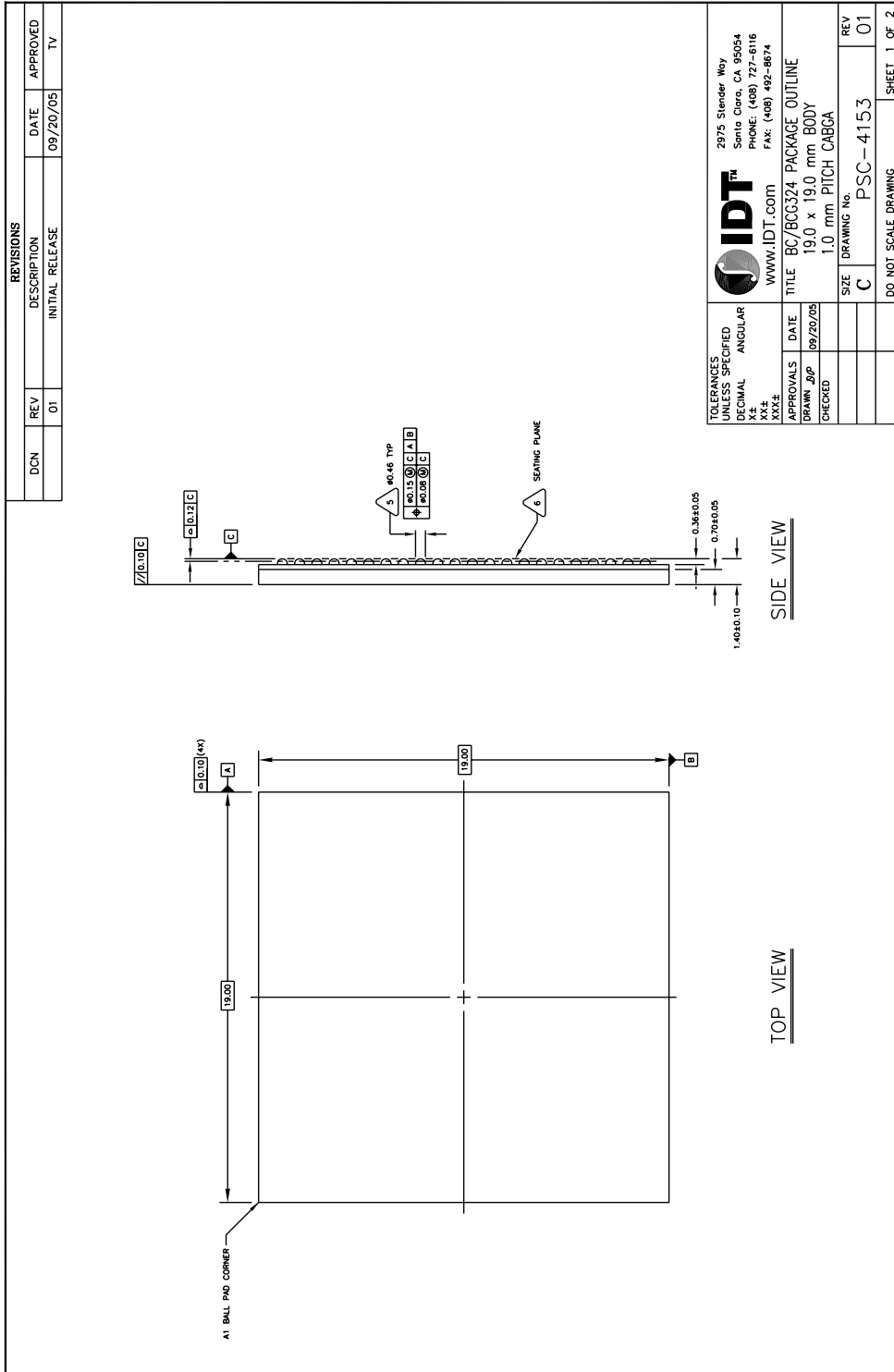

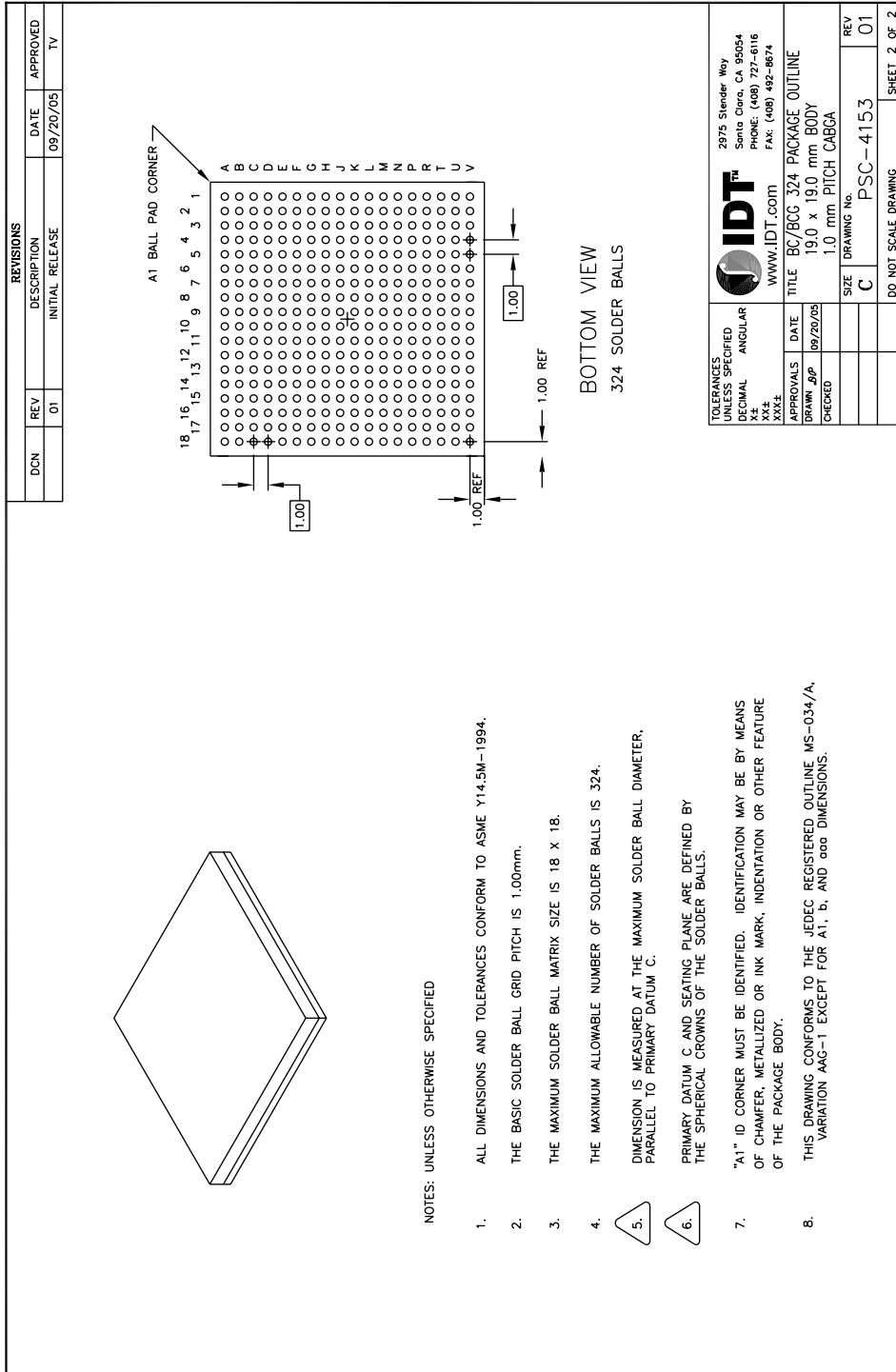

TOLERANCES UNLESS SPECIFIED DECIMAL ANGULAR	<b>IDT™</b>	2975 Slender Way	Santa Clara, CA 95054
XXX	www.IDT.com	PHONE: (408) 727-6116	
XXXX		FAK: (408) 492-8674	
APPROVALS	DATE	TITLE BC/BCG 324 PACKAGE OUTLINE	
DRAWN JJP	09/20/05	19.0 x 19.0 mm BODY	
CHECKED		1.0 mm PITCH CABGA	
	SIZE	DRAWING No.	REV
	C	PSC-4153	01
	DO NOT SCALE DRAWING		SHEET 2 OF 2

## Revision History

February 8, 2007: Initial publication.

April 4, 2007: In Table 3, revised description for MSMBCLK signal.

## Ordering Information

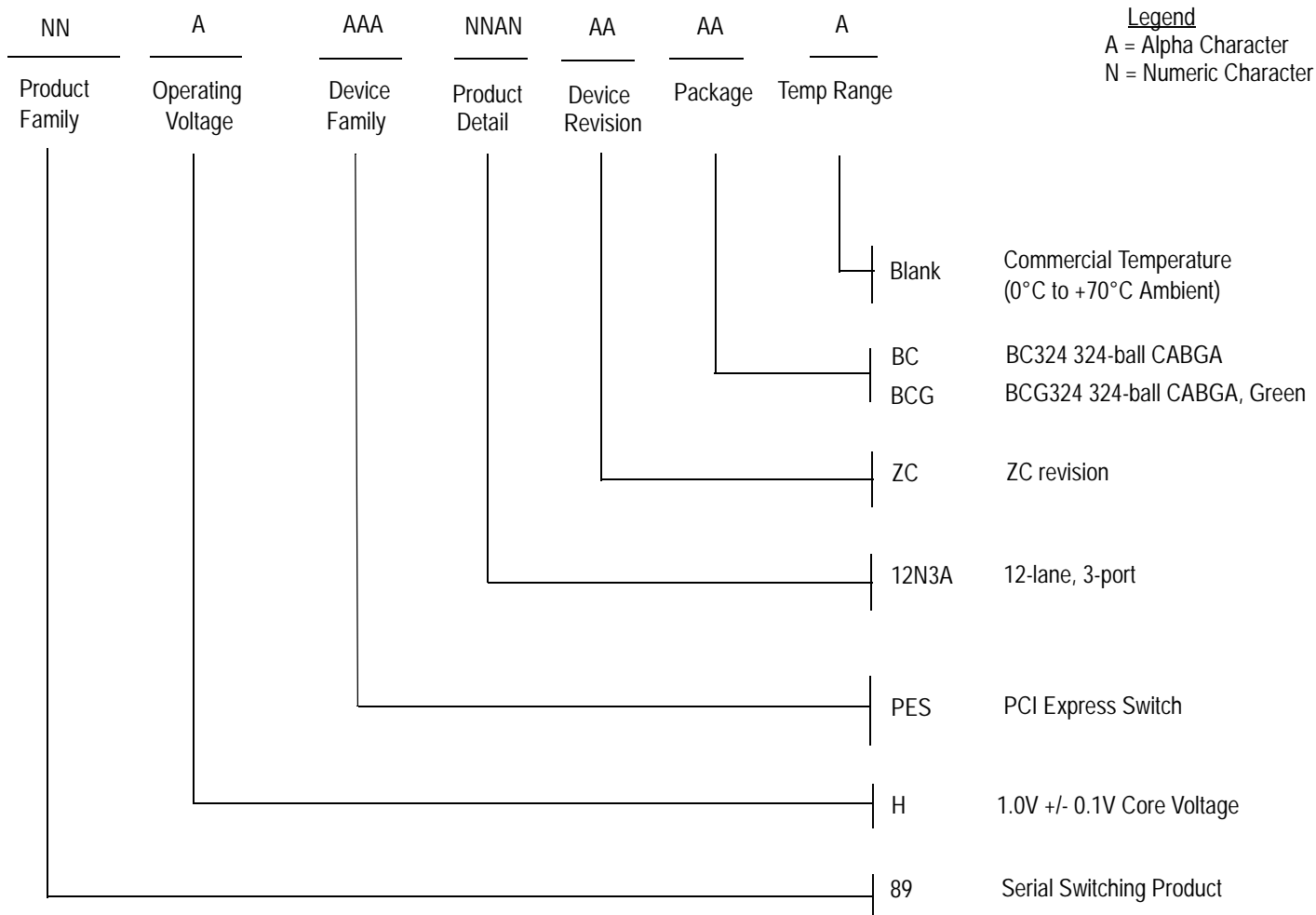

**Legend**

A = Alpha Character  
N = Numeric Character

### Valid Combinations

- 89HPES12N3AZCBC 324-pin BC324 package, Commercial Temperature
- 89HPES12N3AZCBCG 324-pin Green BC324 package, Commercial Temperature



**CORPORATE HEADQUARTERS**  
6024 Silver Creek Valley Road  
San Jose, CA 95138

**for SALES:**  
800-345-7015 or 408-284-8200  
fax: 408-284-2775  
[www.idt.com](http://www.idt.com)

**for Tech Support:**  
email: [ssdhelp@idt.com](mailto:ssdhelp@idt.com)  
phone: 408-284-8208