

## TWO-CHANNEL, 20-BIT, AC '97 2.3 CODECS WITH STEREO MICROPHONE AND MIC/JACK SENSING

## STAC9766/67

### FEATURES

- *For Rev. CC1 parts and beyond*
- High performance  $\Sigma\Delta$  technology
- AC '97 Rev 2.3 Complaint
- 20-bit full duplex stereo ADC & DACs
- Independent sample rates for ADC & DACs
- 5-Wire AC-Link protocol compliance
- 20-bit SPDIF Output
- Full Stereo Microphone Pre-Amp
- Internal Jack Sensing on Headphone & Line\_Out
- Internal Microphone Input Sensing
- Digital PC Beep Option
- Extended AC '97 2.3 Paging Registers
- Digital-ready status
- General purpose I/O
- Crystal Elimination Circuit
- Headphone drive capability (50 mW)
- 0dB, 10dB, 20dB and 30dB microphone boost capability
- +3.3 V (STAC9767) and +5 V (STAC9766) analog power supply options
- Pin compatible with STAC9700/21/56
- 100% compatible with STAC9750/52
- IDT Surround (SS3D) Stereo Enhancement
- Energy saving dynamic power modes
- Multi-Codec option (Intel AC '97 rev 2.3)
- Six analog line-level inputs
- 103dB SNR LINE-LINE

### DESCRIPTION

IDT's STAC9766/67 (Revision CC1 and beyond) are general purpose 20-bit, full duplex, audio CODECs conforming to the analog component specification of AC '97 (Audio Codec 97 Component Specification Rev. 2.3). The STAC9766/67 incorporates IDT's proprietary  $\Sigma\Delta$  technology. The AC '97 CODEC is designed to achieve a DAC SNR in excess of 103dB. The DACs, ADCs and mixer are integrated with analog I/Os, which include four analog line-level stereo inputs, two analog line-level mono inputs, two stereo outputs, and one mono output channel. The

STAC9766/67 includes digital input/output capability for support of modern PC systems with an output that supports the SPDIF format. The STAC9766/67 is a standard 2-channel stereo CODEC. With IDT's headphone drive capability, headphones can be driven with or without an external amplifier.

The STAC9766/67 may be used as a secondary CODEC, with the STAC9700/21/56/08/84/50/52 as the primary, in a multiple CODEC configuration conforming to the AC '97 Rev. 2.3 specification. This configuration can provide the true six-channel, AC-3 playback required for DVD applications. The STAC9766/67 communicates via the five-wire AC-Link to any digital component of AC '97, providing flexibility in the audio system design. Packaged in an AC '97 compliant 48-pin TQFP, the STAC9766/67 can be placed on the motherboard, daughter boards, PCI, AMR, CNR, MDC or ACR cards.

The STAC9766/67 provides variable sample rate Digital-to-Analog (DA) and Analog-to-Digital (AD) conversion, mixing and analog processing.

Supported audio sample rates include 48 kHz, 44.1 kHz, 32 kHz, 22.05 kHz, 16 kHz, 11.025 kHz, and 8 kHz; additional rates are supported in the STAC9766/67 soft audio drivers. All ADCs and DACs operate at 20-bit resolution.

Two 20-bit DACs convert the digital stereo PCM-out content to audio. The MIXER block combines the PCM\_OUT with any analog sources, to drive the LINE\_OUT and HP\_OUT outputs. The MONO\_OUT delivers either microphone only or a mono mix of sources from the MIXER. The stereo, variable-sample-rate, 20-bit ADCs provide record capability for any mix of mono or stereo sources, and deliver a digital stereo PCM-in signal back to the AC-Link. The microphone input and mono mix input can be recorded simultaneously, thus allowing for an all digital output in support of the digital ready initiative. For a digital ready record path, the microphone is connected to the left channel ADC while the mono output of the stereo mixer is connected to right channel ADC.

The STAC9766/67 includes *full Stereo Microphone Pre-Amp* support and can be used with the 10dB, 20dB and 30dB Microphone Boost options. This integration allows for additional cost savings and options.

## DESCRIPTION (CONTINUED)

The STAC9766/67 includes jack sensing on the Headphone and Line\_Out. The STAC9766/67 jack sense can detect the presence of devices on the Headphone and Line Outputs and on both Microphone inputs. With proprietary IDT current and impedance-sensing techniques, the impedance load on the Headphone and Line Outputs can also be detected. The GPIOs on the STAC9766/67 remain available for advanced configurations, unlike previous jack sense implementations.

The STAC9766/67 implementation of jack sense uses the Extended Paging Registers defined by the AC '97 2.3 Specification. This allows for additional registry space to hold the identification information about the CODEC, the jack sensing details and results, and the external surroundings of the CODEC. The information within the Extended Paging Registers will allow for the automatic configuration of the audio subsystem without end-user intervention. For example, the BIOS can populate the Extended Paging Registers with valuable information for both the audio driver and the operating system, such as gain and attenuation stages, input population and input phase. With this input information, the IDT driver will automatically provide to the Volume Control Panel only the volume sliders that are implemented in the system, thus improving the end-user's experience with the PC.

The information in the Extended Paging Registers will also allow for automatic configuration of microphone inputs, the ability to switch between SPDIF and analog outputs, the routing of the master volume slider to the proper physical output and SoftEQ configurations. The fully parametric IDT SoftEQ can be initiated upon jack insertion and sensed impedance levels.

The STAC9766/67 also offers two styles of PC BEEP; Analog and Digital. The digital PC Beep is a new feature added to the AC '97 Specification Rev 2.3.

The STAC9766/67 is designed primarily to support stereo (2-speaker) audio. True AC-3 playback can be achieved for 6-speaker applications by taking advantage of the multi-CODEC option available in the STAC9766/67 to support two or three CODECs in an AC '97 architecture. Additionally, the STAC9766/67 provides for a stereo enhancement feature, IDT Surround 3D (SS3D). SS3D provides the listener with several options for improved speaker separation beyond the normal 2 or 4-speaker arrangements.

The STAC9766/67 can be SoundBlaster® and Windows Sound System® compatible with IDT's WDM driver for Windows 98/2K/ME/XP. SoundBlaster is a registered trademark of Creative Labs. Windows is a registered trademark of Microsoft Corporation.

## KEY SPECIFICATIONS

- Analog LINE\_OUT SNR: 103 dB
- Digital DAC SNR: 95 dB
- Digital ADC SNR: 85 dB
- Full-scale Total Harmonic Distortion: 0.002%
- Crosstalk between Input Channels: -70 dB
- Spurious Tone Rejection: 100 dB

## RELATED MATERIALS

- Data Sheet
- Reference Designs

Figure 1. STAC9766/67 Block Diagram

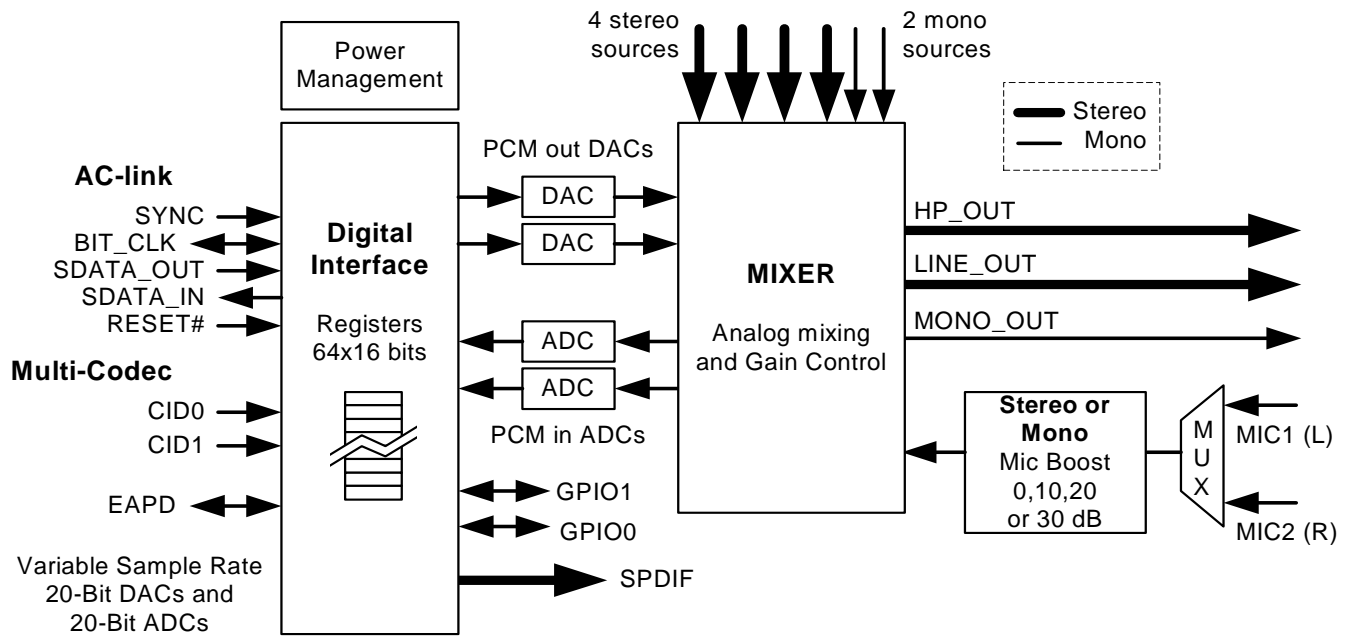

Figure 2. STAC9766 2-Channel Mixer Functional Diagram

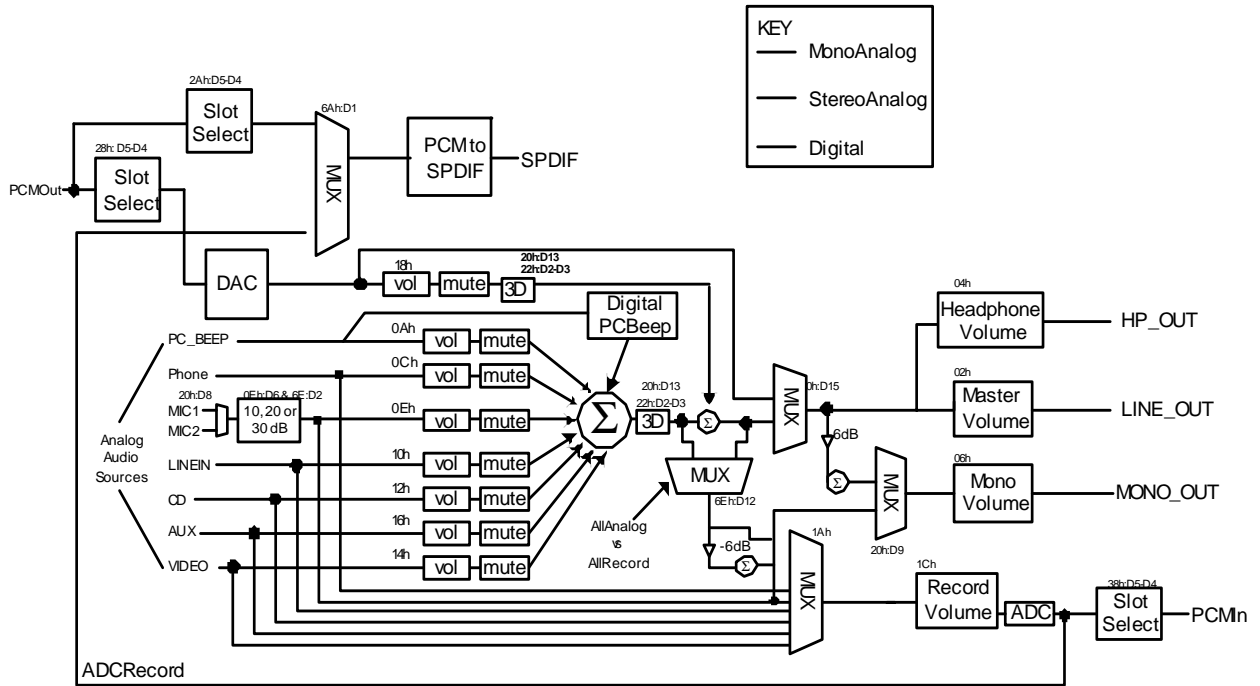

Figure 3. STAC9767 2-Channel Mixer Functional Diagram

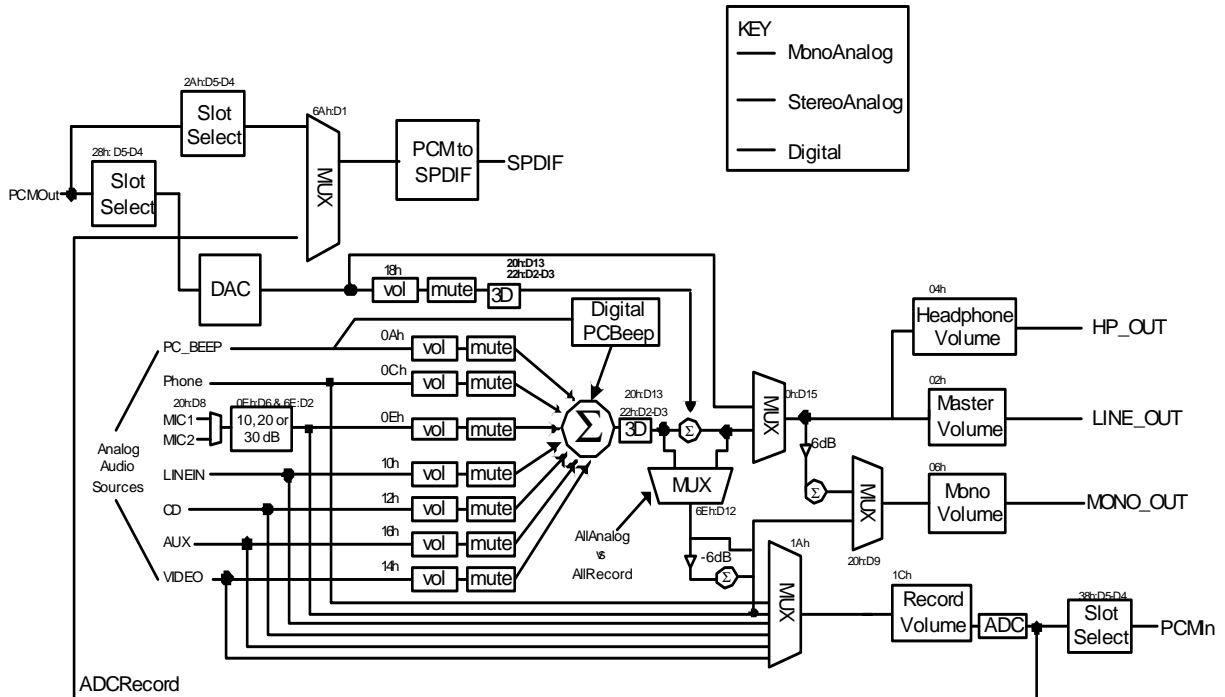
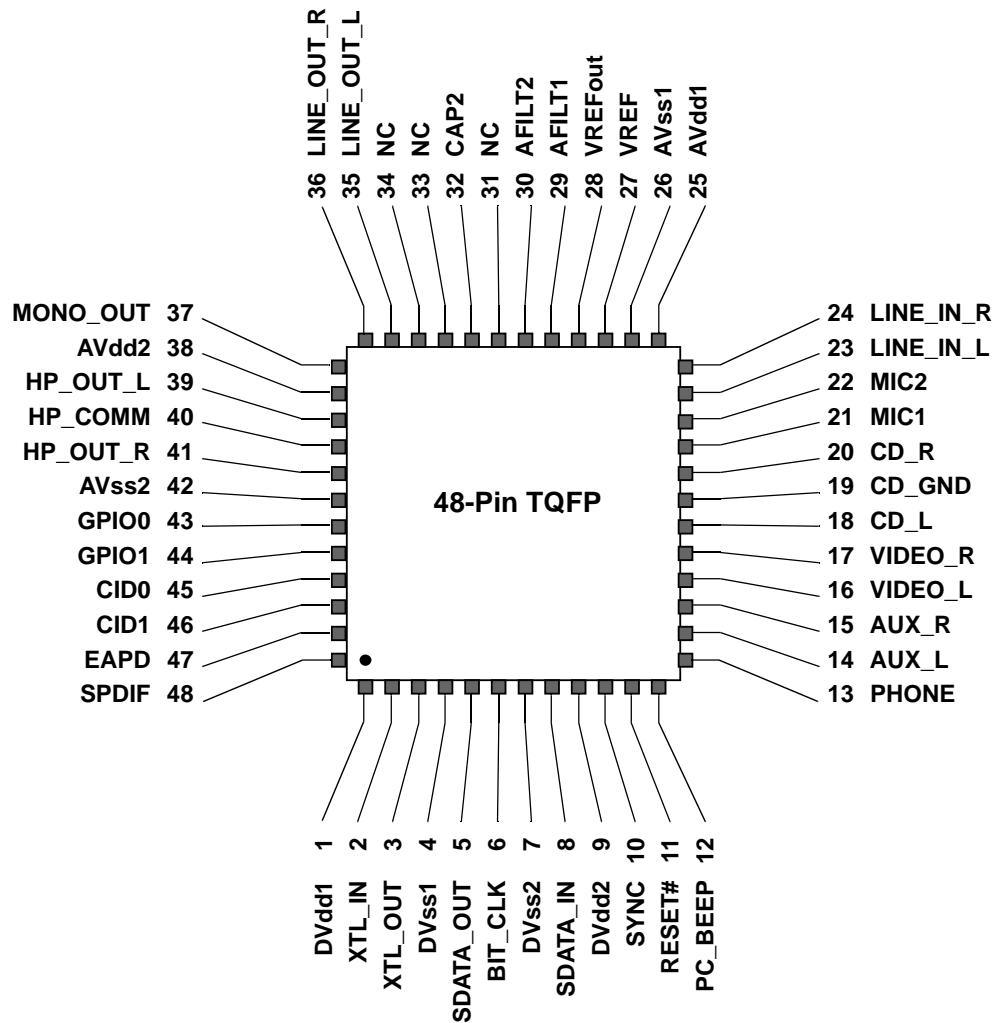

Figure 4. STAC9766/67 Pin Description Drawing



## ORDERING INFORMATION

Part Number	Package	Temp Range	Supply Range
STAC9766T	48-pin TQFP; 7mm x 7mm x 1.4mm	0° C to +70° C	DVdd = 3.3 V, AVdd = 5.0 V
STAC9767T	48-pin TQFP; 7mm x 7mm x 1.4mm	0° C to +70° C	DVdd = 3.3 V, AVdd = 3.3 V

## ADDITIONAL SUPPORT

Additional product and company information can be obtained by going to the IDT website.

**Innovate with IDT audio for high fidelity. Contact:**

[www.IDT.com](http://www.IDT.com)

**For Sales**

800-345-7015  
408-284-8200  
Fax: 408-284-2775

**For Tech Support**

[HA.CM@idt.com](mailto:HA.CM@idt.com)

---

**Corporate Headquarters**

Integrated Device Technology, Inc.  
6024 Silver Creek Valley Road  
San Jose, CA 95138  
United States  
800 345 7015  
+408 284 8200 (outside U.S.)

**Asia Pacific and Japan**

Integrated Device Technology  
Singapore (1997) Pte. Ltd.  
Reg. No. 199707558G  
435 Orchard Road  
#20-03 Wisma Atria  
Singapore 238877  
+65 6 887 5505

**Europe**

IDT Europe, Limited  
321 Kingston Road  
Leatherhead, Surrey  
KT22 7TU  
England  
+44 1372 363 339



[www.IDT.com](http://www.IDT.com)