



FEMTOCLOCKS™ CRYSTAL-TO-3.3V LVPECL CLOCK GENERATOR

ICS843023

GENERAL DESCRIPTION



The ICS843023 is a Gigabit Ethernet Clock Generator and a member of the HiPerClocks™ family of high performance devices from IDT. The ICS843023 uses a 25MHz crystal to synthesize 250MHz. The ICS843023 has excellent phase jitter performance, over the 1.875MHz – 20MHz integration range. The ICS843023 is packaged in a small 8-pin TSSOP, making it ideal for use in systems with limited board space.

FEATURES

- One differential 3.3V LVPECL output
- Crystal oscillator interface designed for 25MHz, 18pF parallel resonant crystal
- Output frequencies: 245MHz – 320MHz
- VCO range: 490MHz - 640MHz
- RMS phase jitter @ 250MHz, using a 25MHz crystal (1.875MHz - 20MHz): 0.39ps (typical)

Offset	Noise Power
100Hz	-86.3 dBc/Hz
1kHz	-114.6 dBc/Hz
10kHz	-125.6 dBc/Hz
100kHz	-126 dBc/Hz

- 3.3V operating supply
- 0°C to 70°C ambient operating temperature
- Available in both standard (RoHS 5) and lead-free (RoHS 6) packages

BLOCK DIAGRAM

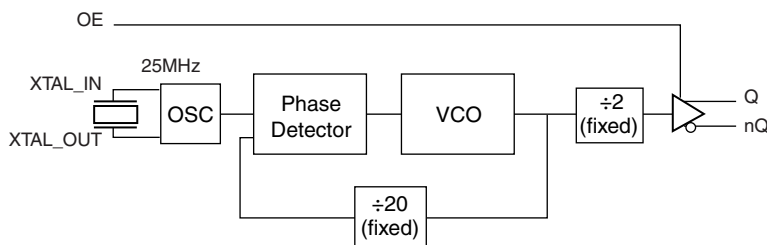

PIN ASSIGNMENT

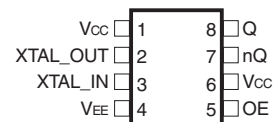

ICS843023

8-Lead TSSOP

4.40mm x 3.0mm x 0.925mm
package body

G Package

Top View

TABLE 1. PIN DESCRIPTIONS

Number	Name	Type		Description
1, 6	V _{CC}	Power		Positive supply pin.
2, 3	XTAL_OUT, XTAL_IN	Input		Crystal oscillator interface. XTAL_IN is the input, XTAL_OUT is the output.
4	V _{EE}	Power		Negative supply pin.
5	OE	Input	Pullup	Active high output enable. When logic HIGH, the outputs are enabled and active. When logic LOW, the outputs are disabled and the device is in the power down mode. LVCMOS/LVTTL interface levels.
7, 8	nQ, Q	Output		Differential clock outputs. LVPECL interface levels.

Pullup refers to internal input resistors. See Table 2, Pin Characteristics, for typical values.

TABLE 2. PIN CHARACTERISTICS

Symbol	Parameter	Test Conditions	Minimum	Typical	Maximum	Units
C _{IN}	Input Capacitance			4		pF
R _{PULLUP}	Input Pullup Resistor			51		kΩ

ABSOLUTE MAXIMUM RATINGS

Supply Voltage, V_{CC}	4.6V
Inputs, V_I	-0.5V to $V_{CC} + 0.5V$
Outputs, I_O	
Continuous Current	50mA
Surge Current	100mA
Package Thermal Impedance, θ_{JA}	101.7°C/W (0 mps)
Storage Temperature, T_{STG}	-65°C to 150°C

NOTE: Stresses beyond those listed under Absolute Maximum Ratings may cause permanent damage to the device. These ratings are stress specifications only. Functional operation of product at these conditions or any conditions beyond those listed in the *DC Characteristics* or *AC Characteristics* is not implied. Exposure to absolute maximum rating conditions for extended periods may affect product reliability.

TABLE 3A. POWER SUPPLY DC CHARACTERISTICS, $V_{CC} = 3.3V \pm 5\%$, $T_A = 0^\circ C$ TO $70^\circ C$

Symbol	Parameter	Test Conditions	Minimum	Typical	Maximum	Units
V_{CC}	Positive Supply Voltage		3.135	3.3	3.465	V
V_{CCA}	Analog Supply Voltage		3.135	3.3	3.465	V
I_{EE}	Power Supply Current				75	mA

TABLE 4B. LVCMOS/LVTTL DC CHARACTERISTICS, $V_{CC} = 3.3V \pm 5\%$, $T_A = 0^\circ C$ TO $70^\circ C$

Symbol	Parameter	Test Conditions	Minimum	Typical	Maximum	Units
V_{IH}	Input High Voltage		2		$V_{CC} + 0.3$	V
V_{IL}	Input Low Voltage		-0.3		0.8	V
I_{IH}	Input High Current	OE $V_{CC} = V_{IN} = 3.465V$			5	μA
I_{IL}	Input Low Current	OE $V_{CC} = 3.465V, V_{IN} = 0V$	-150			μA

TABLE 3C. LVPECL DC CHARACTERISTICS, $V_{CC} = 3.3V \pm 5\%$, $T_A = 0^\circ C$ TO $70^\circ C$

Symbol	Parameter	Test Conditions	Minimum	Typical	Maximum	Units
V_{OH}	Output High Voltage; NOTE 1		$V_{CC} - 1.4$		$V_{CC} - 0.9$	V
V_{OL}	Output Low Voltage; NOTE 1		$V_{CC} - 2.0$		$V_{CC} - 1.7$	V
V_{SWING}	Peak-to-Peak Output Voltage Swing		0.6		1.0	V

NOTE 1: Outputs terminated with 50Ω to $V_{CC} - 2V$.

TABLE 4. CRYSTAL CHARACTERISTICS

Parameter	Test Conditions	Minimum	Typical	Maximum	Units
Mode of Oscillation		Fundamental			
Frequency		24.5		32	MHz
Equivalent Series Resistance (ESR)				50	Ω
Shunt Capacitance				7	pF
Drive Level				1	mW

TABLE 5. AC CHARACTERISTICS, $V_{CC} = 3.3V \pm 5\%$, $T_A = 0^\circ C$ TO $70^\circ C$

Symbol	Parameter	Test Conditions	Minimum	Typical	Maximum	Units
f_{OUT}	Output Frequency		245		320	MHz
$f_{jit}(\emptyset)$	RMS Phase Jitter (Random); NOTE 1	Integration Range: 1.875MHz - 20MHz		0.39		ps
t_R / t_F	Output Rise/Fall Time	20% to 80%	300		600	ps
odc	Output Duty Cycle		47		53	%

NOTE 1: Please refer to the Phase Noise Plot.

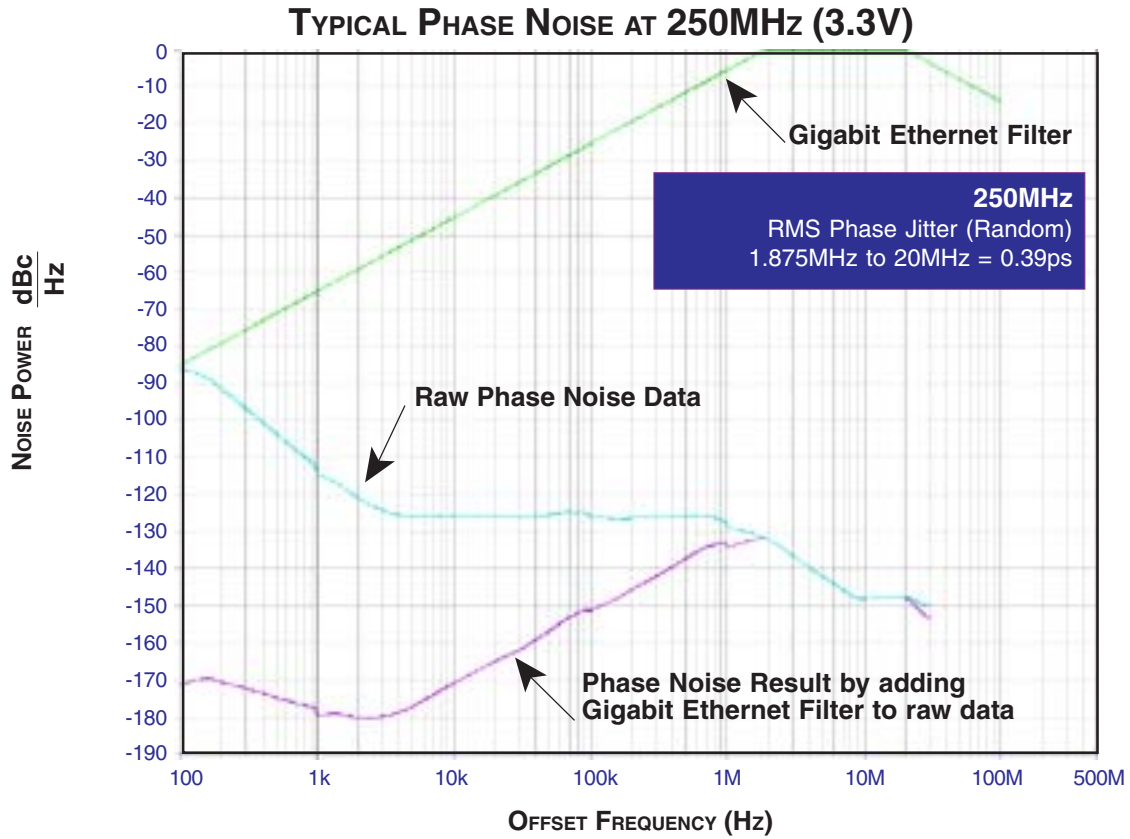

PARAMETER MEASUREMENT INFORMATION

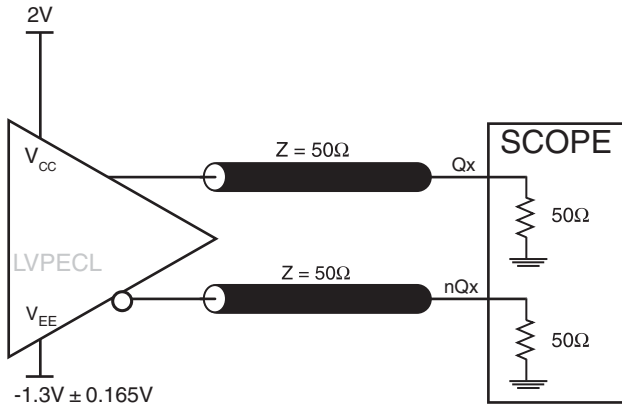

3.3V OUTPUT LOAD AC TEST CIRCUIT

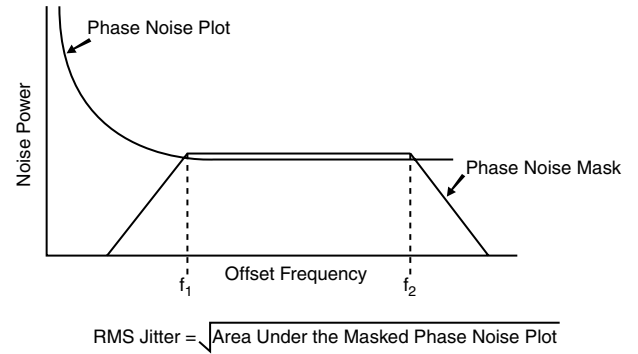

RMS PHASE JITTER

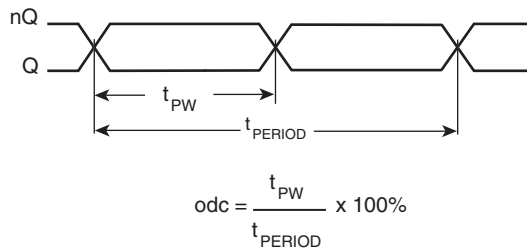

OUTPUT DUTY CYCLE/PULSE WIDTH/PERIOD

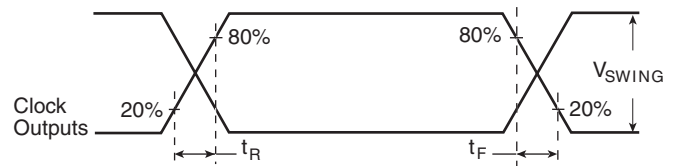

OUTPUT RISE/FALL TIME

APPLICATION INFORMATION

CRYSTAL INPUT INTERFACE

The ICS843023 has been characterized with 18pF parallel resonant crystals. The capacitor values, C1 and C2, shown in *Figure 1* below were determined using a 25MHz, 18pF parallel

resonant crystal and were chosen to minimize the ppm error. The optimum C1 and C2 values can be slightly adjusted for different board layouts.

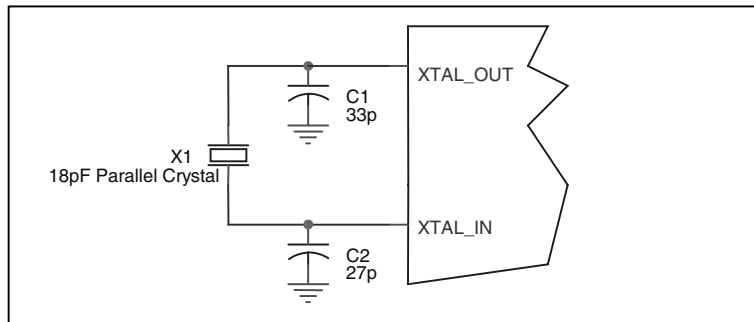

FIGURE 1. CRYSTAL INPUT INTERFACE

LVC MOS TO XTAL INTERFACE

The XTAL_IN input can accept a single-ended LVC MOS signal through an AC coupling capacitor. A general interface diagram is shown in *Figure 2*. The XTAL_OUT pin can be left floating. The input edge rate can be as slow as 10ns. For LVC MOS inputs, it is recommended that the amplitude be reduced from full swing to half swing in order to prevent signal interference with the power rail and to reduce noise. This configuration requires that the output

impedance of the driver (R_o) plus the series resistance (R_s) equals the transmission line impedance. In addition, matched termination at the crystal input will attenuate the signal in half. This can be done in one of two ways. First, R_1 and R_2 in parallel should equal the transmission line impedance. For most 50Ω applications, R_1 and R_2 can be 100Ω. This can also be accomplished by removing R_1 and making R_2 50Ω.

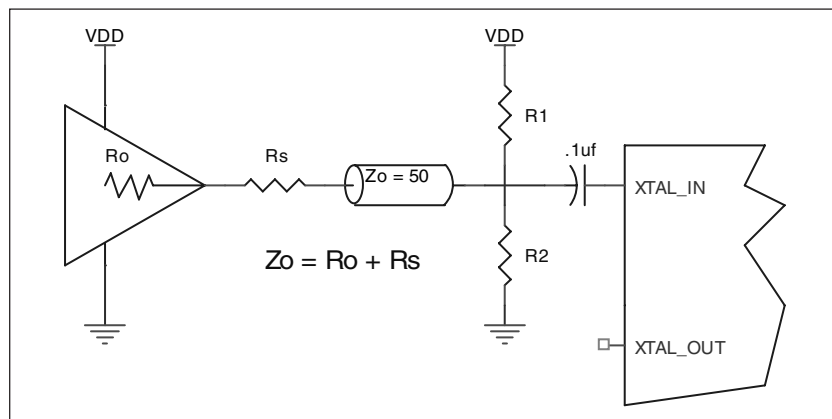

FIGURE 2. GENERAL DIAGRAM FOR LVC MOS DRIVER TO XTAL INPUT INTERFACE

TERMINATION FOR 3.3V LVPECL OUTPUT

The clock layout topology shown below is a typical termination for LVPECL outputs. The two different layouts mentioned are recommended only as guidelines.

FOUT and nFOUT are low impedance follower outputs that generate ECL/LVPECL compatible outputs. Therefore, terminating resistors (DC current path to ground) or current sources must be used for functionality. These outputs are designed to drive 50Ω

transmission lines. Matched impedance techniques should be used to maximize operating frequency and minimize signal distortion. *Figures 3A and 3B* show two different layouts which are recommended only as guidelines. Other suitable clock layouts may exist and it would be recommended that the board designers simulate to guarantee compatibility across all printed circuit and clock component process variations.

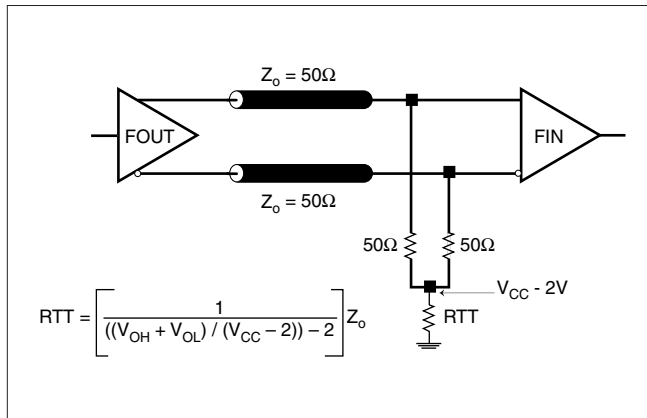

FIGURE 3A. LVPECL OUTPUT TERMINATION

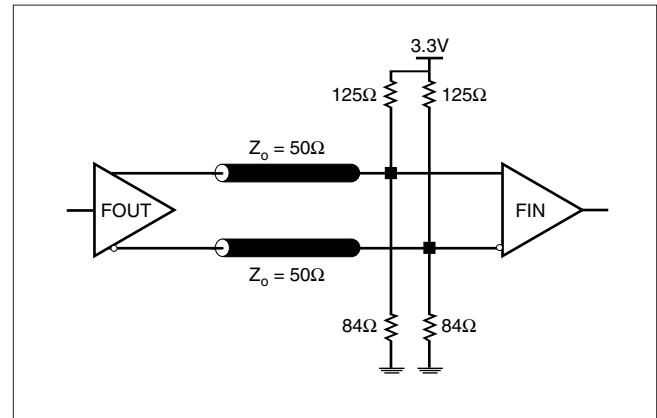

FIGURE 3B. LVPECL OUTPUT TERMINATION

POWER CONSIDERATIONS

This section provides information on power dissipation and junction temperature for the ICS843023. Equations and example calculations are also provided.

1. Power Dissipation.

The total power dissipation for the ICS843023 is the sum of the core power plus the power dissipated in the load(s). The following is the power dissipation for $V_{CC} = 3.3V + 5\% = 3.465V$, which gives worst case results.

NOTE: Please refer to Section 3 for details on calculating power dissipated in the load.

- Power (core)_{MAX} = $V_{CC,MAX} * I_{EE,MAX} = 3.465V * 75mA = 259.87mW$
- Power (outputs)_{MAX} = **30mW/Loaded Output pair**

$$\text{Total Power}_{MAX} (3.465V, \text{ with all outputs switching}) = 259.87mW + 30mW = 289.87mW$$

2. Junction Temperature.

Junction temperature, T_j , is the temperature at the junction of the bond wire and bond pad and directly affects the reliability of the device. The maximum recommended junction temperature for HiPerClockS™ devices is 125°C.

The equation for T_j is as follows: $T_j = \theta_{JA} * Pd_{total} + T_A$

T_j = Junction Temperature

θ_{JA} = Junction-to-Ambient Thermal Resistance

Pd_{total} = Total Device Power Dissipation (example calculation is in section 1 above)

T_A = Ambient Temperature

In order to calculate junction temperature, the appropriate junction-to-ambient thermal resistance θ_{JA} must be used. Assuming a moderate air flow of 1 meter per second and a multi-layer board, the appropriate value is 90.5°C/W per Table 6 below.

Therefore, T_j for an ambient temperature of 70°C with all outputs switching is:

$$70^\circ\text{C} + 0.290W * 90.5^\circ\text{C}/\text{W} = 96.2^\circ\text{C}. \text{ This is well below the limit of } 125^\circ\text{C}.$$

This calculation is only an example. T_j will obviously vary depending on the number of loaded outputs, supply voltage, air flow, and the type of board (single layer or multi-layer).

TABLE 6. THERMAL RESISTANCE θ_{JA} FOR 8-PIN TSSOP, FORCED CONVECTION

θ_{JA} by Velocity (Meters per Second)			
	0	1	2.5
Multi-Layer PCB, JEDEC Standard Test Boards	101.7°C/W	90.5°C/W	89.8°C/W

3. Calculations and Equations.

The purpose of this section is to derive the power dissipated into the load.

LVPECL output driver circuit and termination are shown in *Figure 4*.

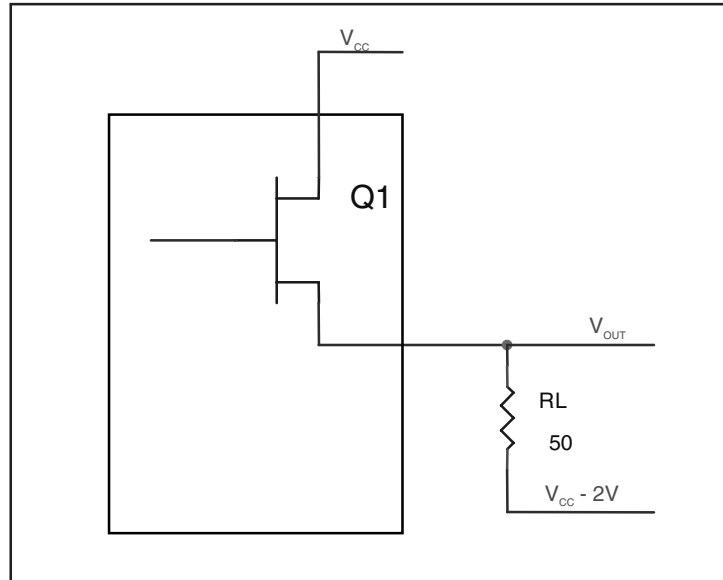

FIGURE 4. LVPECL DRIVER CIRCUIT AND TERMINATION

To calculate worst case power dissipation into the load, use the following equations which assume a 50Ω load, and a termination voltage of $V_{CC} - 2V$.

- For logic high, $V_{OUT} = V_{OH_MAX} = V_{CC_MAX} - 0.9V$

$$(V_{CC_MAX} - V_{OH_MAX}) = 0.9V$$

- For logic low, $V_{OUT} = V_{OL_MAX} = V_{CC_MAX} - 1.7V$

$$(V_{CC_MAX} - V_{OL_MAX}) = 1.7V$$

Pd_H is power dissipation when the output drives high.

Pd_L is the power dissipation when the output drives low.

$$Pd_H = [(V_{OH_MAX} - (V_{CC_MAX} - 2V))/R_L] * (V_{CC_MAX} - V_{OH_MAX}) = [(2V - (V_{CC_MAX} - V_{OH_MAX}))/R_L] * (V_{CC_MAX} - V_{OH_MAX}) = [(2V - 0.9V)/50\Omega] * 0.9V = 19.8mW$$

$$Pd_L = [(V_{OL_MAX} - (V_{CC_MAX} - 2V))/R_L] * (V_{CC_MAX} - V_{OL_MAX}) = [(2V - (V_{CC_MAX} - V_{OL_MAX}))/R_L] * (V_{CC_MAX} - V_{OL_MAX}) = [(2V - 1.7V)/50\Omega] * 1.7V = 10.2mW$$

Total Power Dissipation per output pair = $Pd_H + Pd_L = 30mW$

RELIABILITY INFORMATION

TABLE 7. θ_{JA} VS. AIR FLOW TABLE FOR 8 LEAD TSSOP

θ_{JA} by Velocity (Meters per Second)			
	0	1	2.5
Multi-Layer PCB, JEDEC Standard Test Boards	101.7°C/W	90.5°C/W	89.8°C/W

TRANSISTOR COUNT

The transistor count for ICS843023 is: 2360

PACKAGE OUTLINE - G SUFFIX FOR 8 LEAD TSSOP

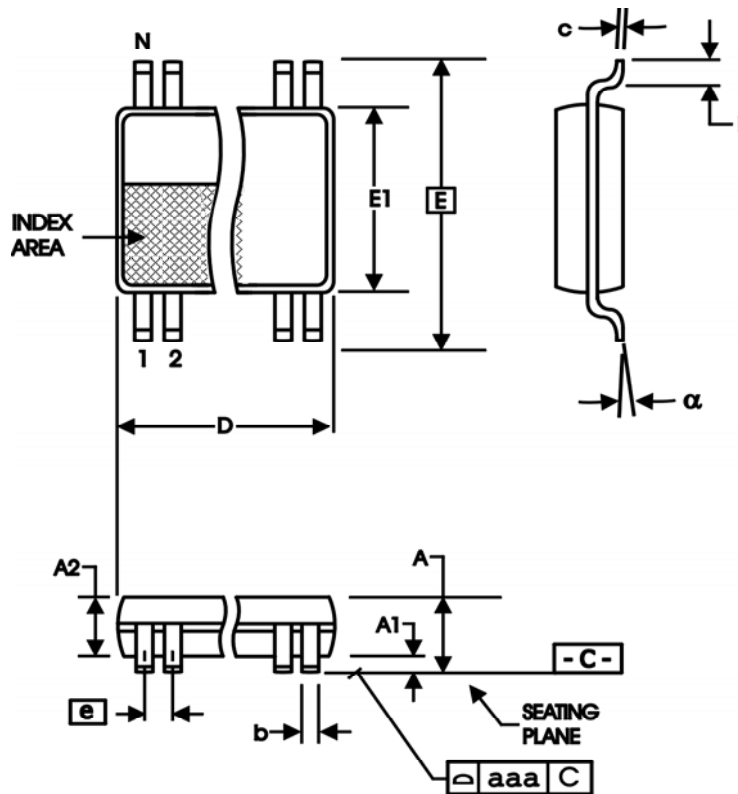

TABLE 8. PACKAGE DIMENSIONS

SYMBOL	Millimeters	
	Minimum	Maximum
N	8	
A	--	1.20
A1	0.05	0.15
A2	0.80	1.05
b	0.19	0.30
c	0.09	0.20
D	2.90	3.10
E	6.40 BASIC	
E1	4.30	4.50
e	0.65 BASIC	
L	0.45	0.75
α	0°	8°
aaa	--	0.10

Reference Document: JEDEC Publication 95, MO-153

REVISION HISTORY SHEET

Rev	Table	Page	Description of Change	Date
A	T9	6	Added LVCMOS to XTAL Interface.	12/22/06
		12	Ordering Information Table - corrected temperature from -40 to 85°C to 0 to 70°C.	
A		1	Features Section - corrected RMS Phase Jitter integration range.	2/14/08

Innovate with IDT and accelerate your future networks. Contact:

www.IDT.com

Corporate Headquarters

Integrated Device Technology, Inc.
6024 Silver Creek Valley Road
San Jose, CA 95138
United States
800 345 7015
+408 284 8200 (outside U.S.)

Japan

NIPPON IDT KK
Sanbancho Tokyu Bld. 7F,
8-1 Sanbancho
Chiyoda-ku, Tokyo 102-0075
+81 3 3221 9822
+81 3 3221 9824 (fax)

Asia

Integrated Device Technology
IDT (S) Pte. Ltd.
1 Kallang Sector, #07-01/06
Kolam Ayer Industrial Park
Singapore 349276
+65 6 744 3356
+65 6 744 1764 (fax)

Europe

IDT Europe, Limited
321 Kingston Road
Leatherhead, Surrey
KT22 7TU
England
+44 (0) 1372 363 339
+44 (0) 1372 378851 (fax)