

ABSTRACT

Battery operated computer systems, such as notebook computers, need support logic with a combination of high-speed and low power. High-speed logic is required to support high-speed microprocessors. Low power is required to maximize battery life. Three volt LVTTTL logic families such as IDT's FCT, LVC & ALVC, have been introduced to supply these needs. The 3V logic families have the same TTL I/O specifications as their 5V relatives (5VTTL) but with a 3.3V VCC instead of 5V. Many systems have a mixture of 5V TTL and 3V TTL components, and conversion between the two types is required to prevent damage to the 3V components even though their logic levels are compatible. The IDT's QS3861 QuickSwitch bus switches can be used to provide this conversion automatically without requiring control logic or introducing propagation delay.

BACKGROUND

A common problem in low power system design is a requirement for a mixture of 5V and 3V logic because some functions are not yet available in 3V form. An example of such a system is shown in Figure 1. The CPU and DRAM use 3.3V supply, while the EPROM and I/O devices use 5V supply. A 5V to 3V converter is shown in Figure 1 because the 5V TTL cannot, in general, drive the 3V TTL even though their logic levels are compatible. A 5V CMOS driver will drive the bus to 5V at a logic HIGH. Even low voltage swing TTL devices such as the FCT family have TTL HIGH output voltages above 4.0V. The 3V LVTTTL devices cannot withstand more than approximately 3.3V on their I/O pins. If an I/O pin of a 3V LVTTTL device is driven above its 3.3V VCC, the P Channel device in the output driver will conduct causing current flow from the bus to the 3.3V VCC through the device. The resulting high-current flow can cause destruction of the 3V TTL device output through latchup effects. The function of the 5V to 3V converter is to limit the voltage seen by the 3V TTL device to acceptable levels, typically no more than the 3.3V supply 0.5V.

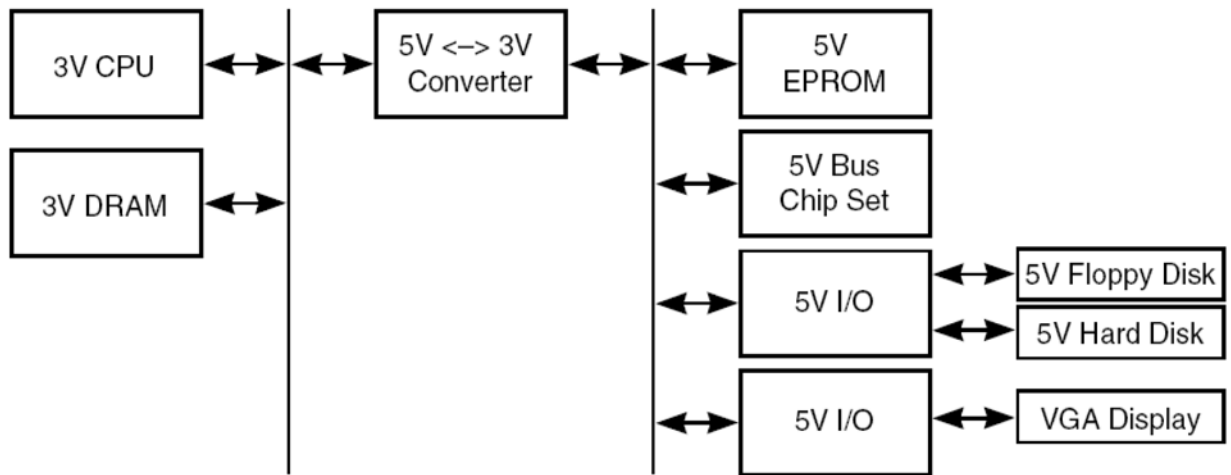

Figure 1. 5V & 3V Logic Mixture in PC Design

A 5V TTL to 3V LVTTTL converter could consist of specialized buffers and transceivers which accept 5V TTL levels on one side and 3V TTL levels on the other. These parts add propagation delay to the signal path, and require data direction control and power sequencing.

Fortunately a simpler solution exists for 5V and 3V translation. The QuickSwitch® bus switch family. These devices can be used to provide bidirectional 5V to 3V conversion with no added propagation delay or direction control. Under the appropriate conditions, the QuickSwitch will accept 5V TTL signals on the driving side while limiting the voltage output to 3.3V on the driven side. Also, the QuickSwitch is equivalent to a 5 Ohm resistor when on, so that it adds no significant propagation delay to signals passing through it. To understand this, we will examine the QuickSwitch® and its operation.

THE QUICKSWITCH CMOS BUS SWITCH

The basic element of the QuickSwitch is a fast, low ON resistance, low capacitance, high-current capacity switch. The combination of low ON resis-

tance and low capacitance is provided by the IDT's high-performance CMOS process. Each switch consists of an N channel MOS transistor driven by a CMOS logic gate, as shown in Figure 2.

When the switch is enabled, the gate of the N channel transistor is at V_{CC} (5V) and the device is on, with a typical on resistance of 5 Ohm. When disabled, the gate of the switch is at 0V and the switch is off. OFF state leakage is in the form of diode leakage to the substrate (ground) and is typically 10nA at room temperature. OFF state capacitance across the switch itself is small because the input and output pins are shielded to some degree by the gate, which is grounded.

These devices have an ON resistance of less than 5 Ohm for input voltages near ground. The resistance rises somewhat as the I/O voltage rises from a TTL LOW of 0.0V to a TTL HIGH of 2.4V. In this region the A and B pins are solidly connected. As the switch input voltage rises, the output follows closely. At approximately 4V at the input, the output reaches its highest voltage. For input voltages higher than 4V, the output will remain clamped at 4V. This is shown in the V_{OUT} vs. V_{IN} charts in Figures 3 and 4.

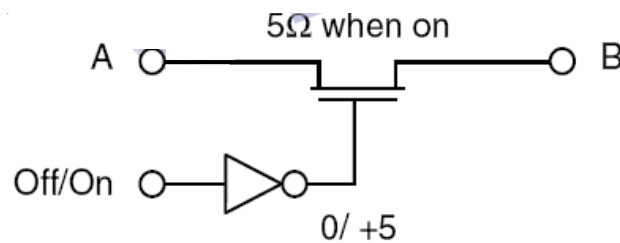

Figure 2. QuickSwitch Block Diagram

QUICKSWITCH VOUT VS. VCC

The QuickSwitch output voltage for an input voltage equal to VCC is approximately 1.0V below VCC. This voltage drop varies from 1.0V at light loading (μA) to 1.5V at heavier loading (mA). Increasing or decreasing VCC will increase or decrease the output voltage by the same amount, as shown in

the plot below. In this plot, the "Delta V" curves shown the difference between the output and VCC, i.e., the voltage drop across the switch. The output limit of 1.0V below VCC is because an N channel transistor is used as the switch which turns off as its gate to source voltage falls below this value.

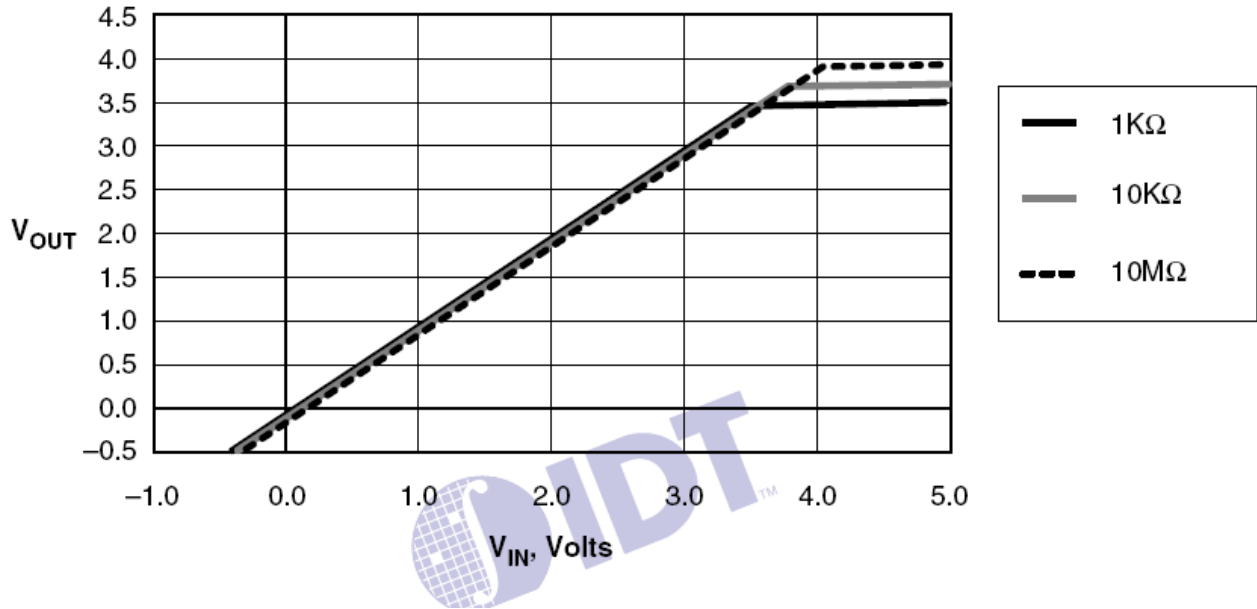

Figure 3. QuickSwitch VOUT vs. VIN

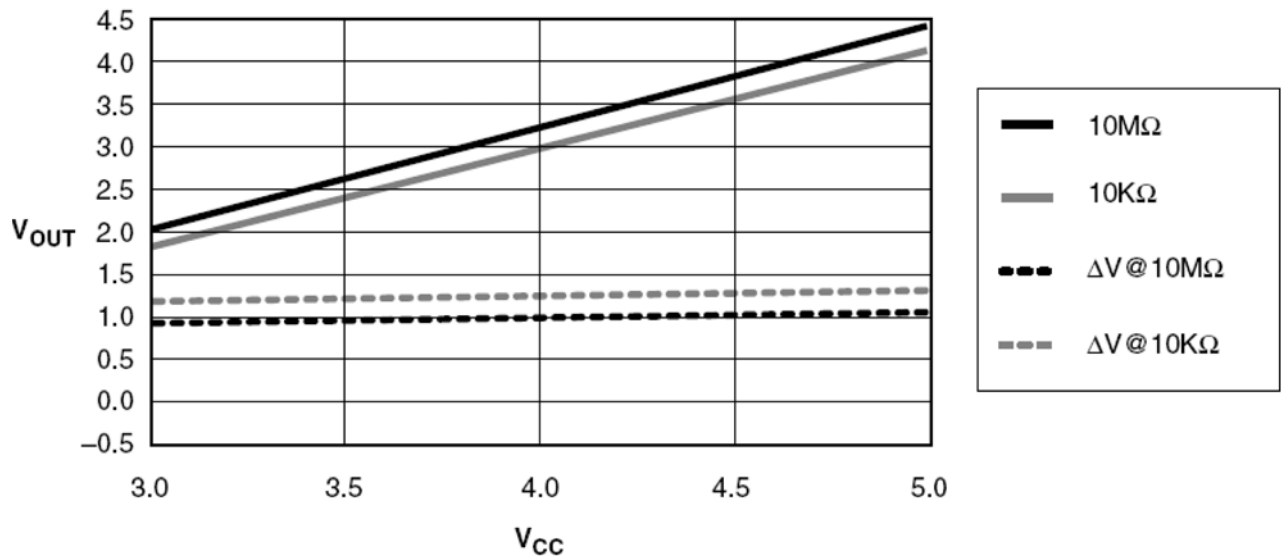

Figure 4. QuickSwitch VOUT and Voltage Drop vs. VCC at VIN = VCC

QUICKSWITCH AS A 5V TTL TO 3V TTL CONVERTER

The output limiting characteristics of the QuickSwitch can be used to make a very efficient 5V TTL to 3V TTL converter. By supplying 4.3V to the V_{CC} pin of a QuickSwitch device such as the QS3861, the driven output will be limited to 3.3V maximum, even under light loading. A 4.3V V_{CC} can be created by adding a diode, such as a 1N4148 between the 5V supply and the device. The

diode will provide approximately 0.70V drop, supplying the QS3861 with a V_{CC} of 4.3V. A 10kOhm resistor is added between the diode's cathode and ground to provide a current path for the diode.* This is shown below.

The QS3861 devices provide 10 bits of conversion per device. A bus with a 24-bit address bus, a 16-bit data bus, and up to 10 control lines would require five devices. Note that the conversion is bidirectional and automatic. If either side is driven to 5V, the driven side will be limited to 3.3V.

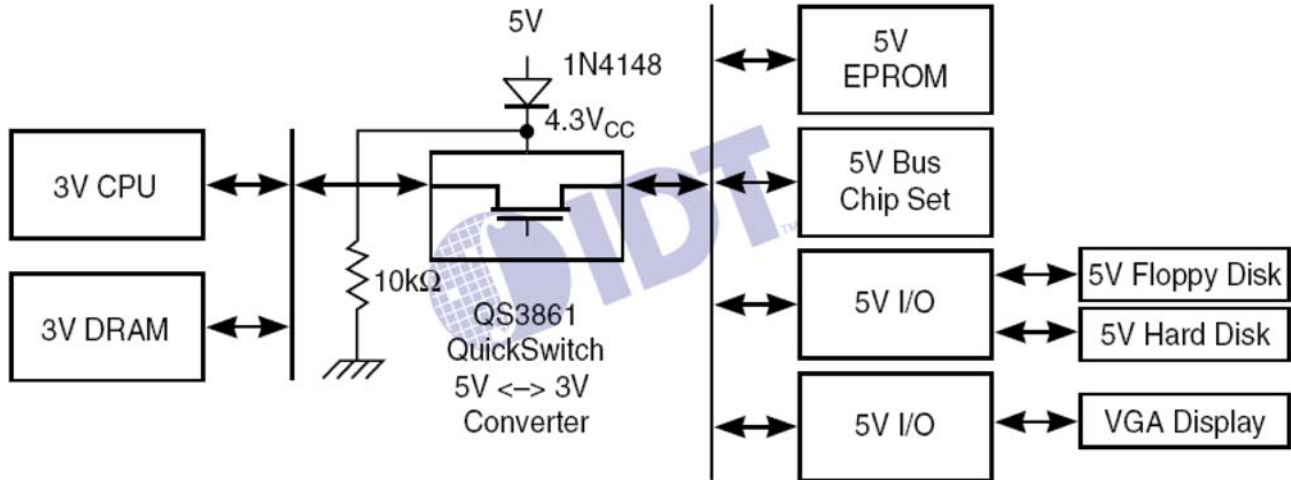

Figure 5. System with QS3861 as 5V TTL to 3V TTL Converter

*IDT also offers some devices such as QS3384 which have an internal current path from V_{CC} to ground. These devices have a specified maximum power supply current of 1.5mA and do not require the external bias resistor shown in Figure 5.

PERFORMANCE OF THE QUICKSWITCH 5V TTL TO 3V TTL CONVERTER

Figures 6 and 7 show the performance of the QS3861 QuickSwitch as a 5V TTL to 3V TTL converter. Figures 6A and 6B show V_{OH} versus I_{OH} for 3.3V and 5.0V inputs respectively. Figure 7 shows the input and output waveforms for a 5V pulse driving a standard 50pF 500 Ohm load through the QS3861.

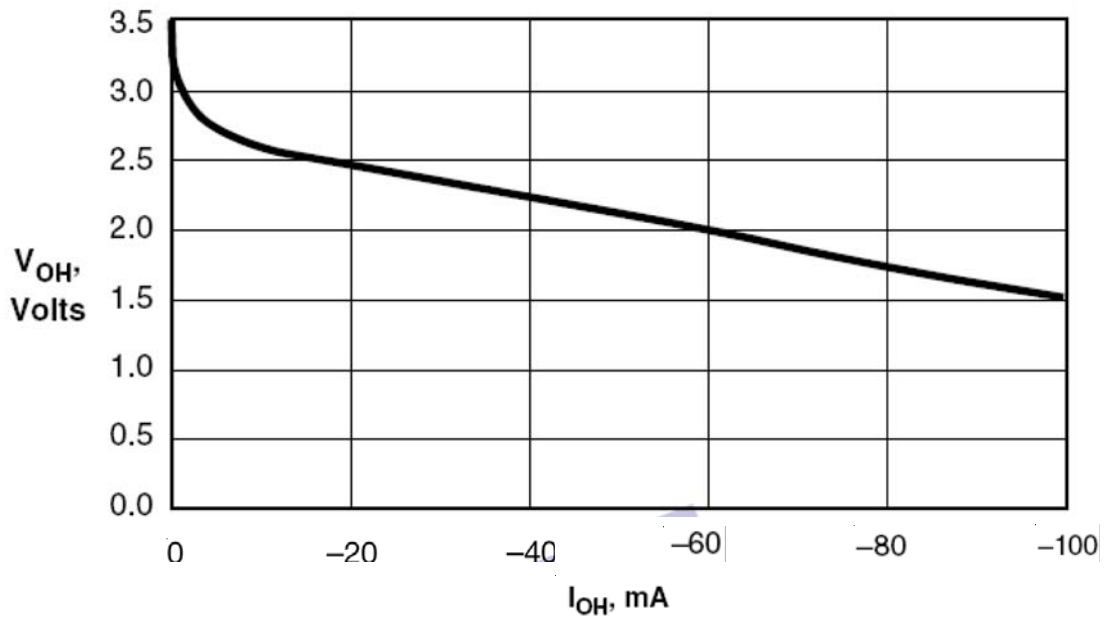

Figure 6A. V_{OH} vs. I_{OH} for QS3861 with $V_{CC} = 4.3V$ & $V_{IN} = 3.3$

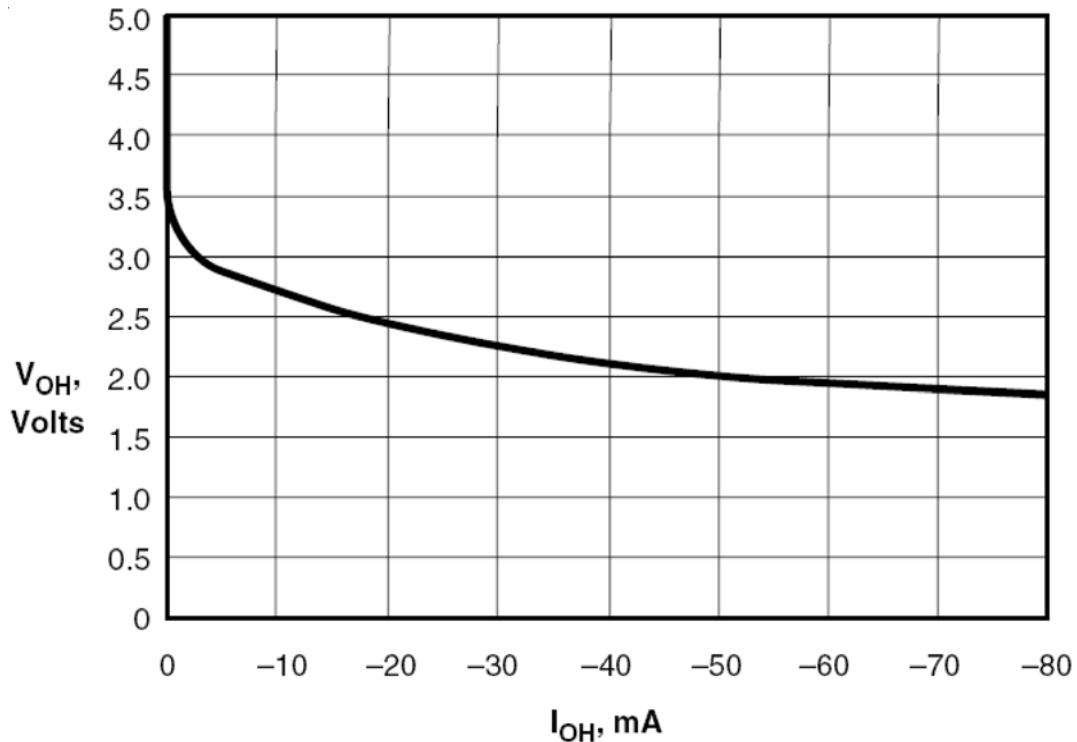

Figure 6B. V_{OH} vs. I_{OH} for QS3861 with $V_{CC} = 4.3V$ & $V_{IN} = 5.0V$

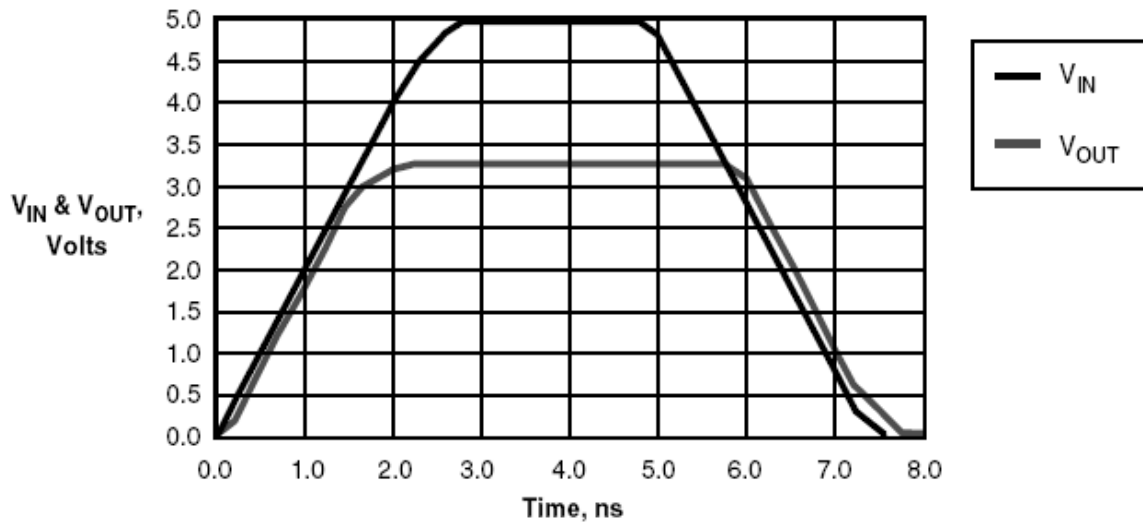

Figure 7. Input to Output Delay of QS3861 at V_{cc} = 4.3V

CONCLUSION

IDT's QuickSwitch devices offer a simple, effective solution for operating 5V TTL and 3.3V LVTTTL devices in mixed supply systems. The QuickSwitch provides voltage conversion without adding propagation delay.

POSTSCRIPT

Since the initial publication of this application note, several products have been added to facilitate voltage translation. These include 16-bit, 24-bit and 32-bit wide switches and a variety of multiplexers and bus exchangers. Please see IDT's web page, www.IDT.com for details.



CORPORATE HEADQUARTERS
6024 Silver Creek Valley Road
San Jose, Ca 95138

for SALES:
800-345-7015 or 408-284-8200
fax: 408-284-2775

for TECH SUPPORT:
LOGIChelp@idt.com