

NOTES:

1. ALL DIMENSIONS AND TOLERANCES ARE PER ASME Y14.5M-1994.
  2. ALL DIMENSIONS ARE IN MILLIMETERS.
- ▲ SEATING PLANE AND PRIMARY DATUM -C- ARE DEFINED BY THE CONTACT POINTS OF THREE OR MORE SOLDER BALLS THAT SUPPORT THE DEVICE WHEN PLACED ON A TOP OF A PLANAR SURFACE.
- ▲ BOTTOM PIN#1 INDICATOR OPTIONAL.

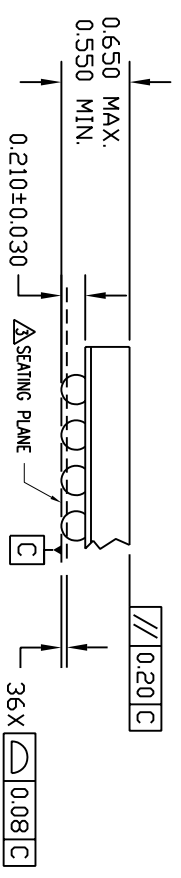
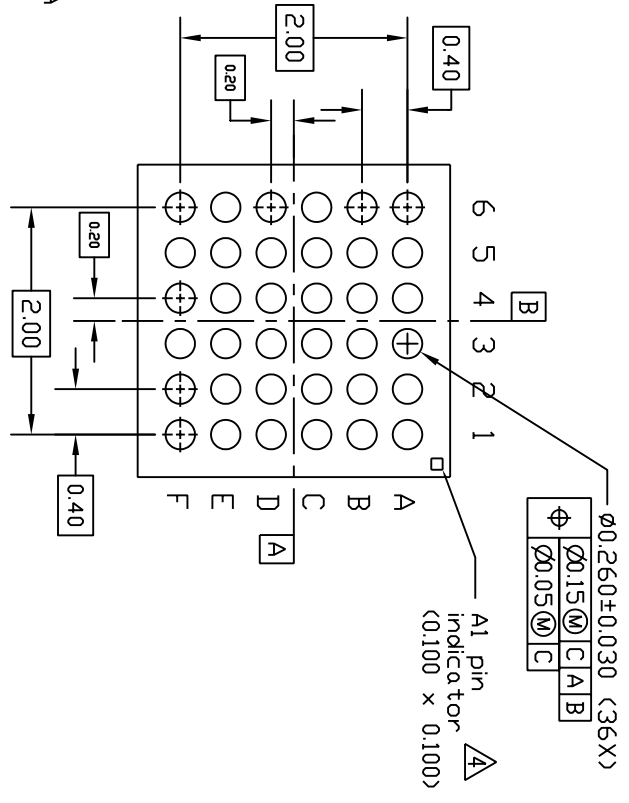
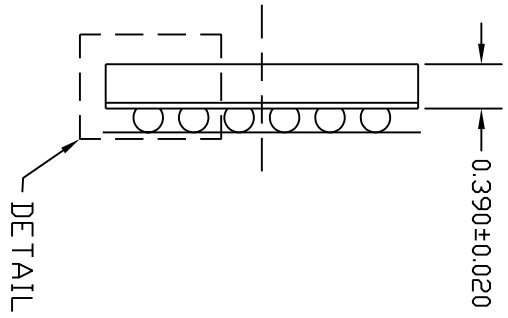
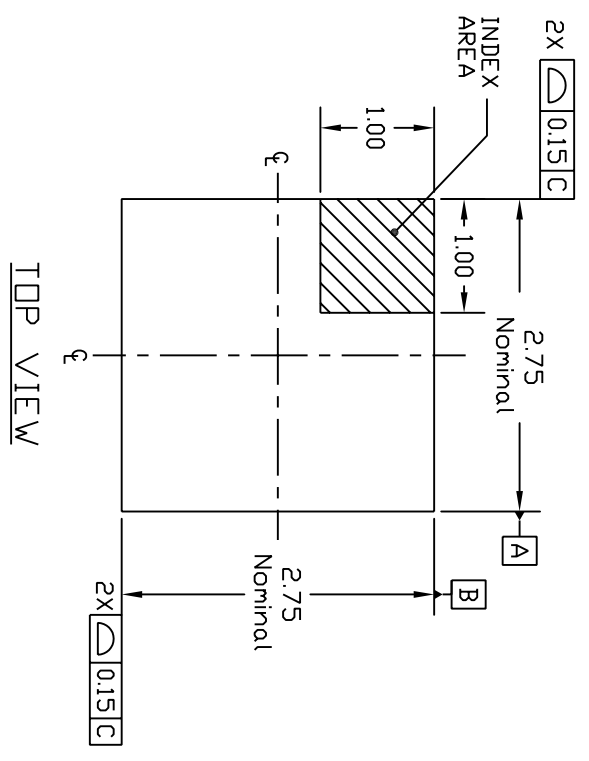

DETAIL A  
(ROTATED 90 DEG CW)

REVISIONS		DCN	REV	DESCRIPTION	DATE	APPROVED
			00	INITIAL RELEASE	02/04/11	MJR

**TOLERANCES UNLESS SPECIFIED**

DECIMAL	xxx 0.05
ANGULAR	±
DRAWN	MJR
CHECKED	xxxxx
APPROVALS	DATE
	19/11/10

WWW.IDT.COM

**IDT™**

6024 SILVER CREEK VALLEY ROAD, SAN JOSE, CA 95138  
PHONE: (408) 284-8200  
FAX: (408) 284-3572

TITLE: AHG36 PACKAGE OUTLINE  
2.75 x 2.75 mm BODY  
0.4mm PITCH DSBGA

SIZE: C  
DRAWING No.: PSC-4319  
REV: 00

DO NOT SCALE DRAWING

SHEET 1 OF 1