

DATE CREATED	REVISIONS		
	REV	DESCRIPTION	AUTHOR
8/26/16	00	INITIAL RELEASE	JH
5/23/17	01	CORRECT EPAD DRAWING	JH

NOTE: REFER TO DCP FOR OFFICIAL RELEASE DATE

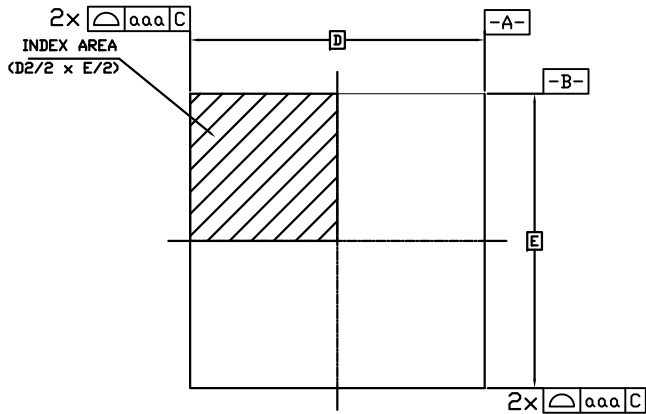

TOP VIEW

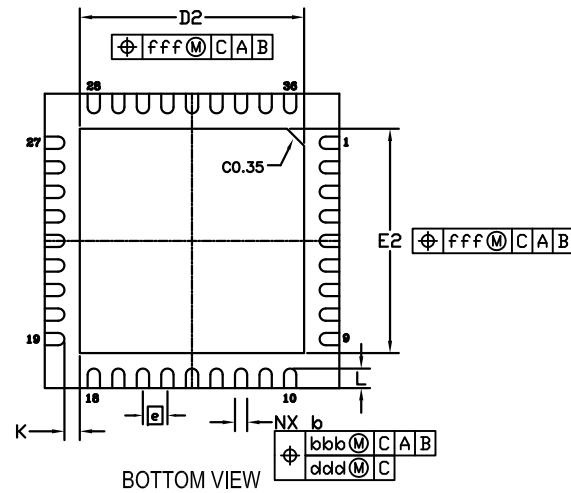

BOTTOM VIEW

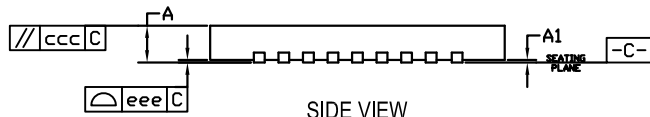

SIDE VIEW

SYMBOL	DIMENSION		
	MIN	NOM	MAX
L	0.35	0.40	0.45
D	6.00 BSC		
E	6.00 BSC		
D2	4.47	4.57	4.67
E2	4.47	4.57	4.67
e	0.50 BSC		
A	0.70	0.75	0.80
A1	0.00	0.02	0.05
b	0.20	0.25	0.30
K	0.315 REF		
aaa	0.15		
bbb	0.10		
ccc	0.10		
ddd	0.05		
eee	0.08		
fff	0.10		

NOTES:

1. ALL DIMENSIONING AND TOLERANCING CONFORM TO ANSI Y14.5M-1982
2. ALL DIMENSIONS ARE IN MILLIMETERS.

TOLERANCES  
UNLESS SPECIFIED  
DECIMAL ANGULAR  
X± .1 ±1°  
XX± .05  
XXX± .030



6024 SILVER CREEK  
VALLEY ROAD, SAN JOSE,  
CA 95138  
PHONE: (408) 284-8200  
FAX: (408) 284-3572

TITLE NB/NBG36P3 PACKAGE OUTLINE  
6.0 x 6.0 mm BODY, EPAD 4.57 mm SQ  
0.50 mm PITCH QFN

SIZE C	DRAWING No. PSC-4311-03	REV 01
-----------	----------------------------	-----------

DO NOT SCALE DRAWING SHEET 1 OF 2

DATE		REVISIONS	
CREATED	REV	DESCRIPTION	AUTHOR
8/26/16	00	INITIAL RELEASE	JH
5/23/17	01	CORRECT EPAD DRAWING	JH

NOTE: REFER TO DCP FOR OFFICIAL RELEASE DATE

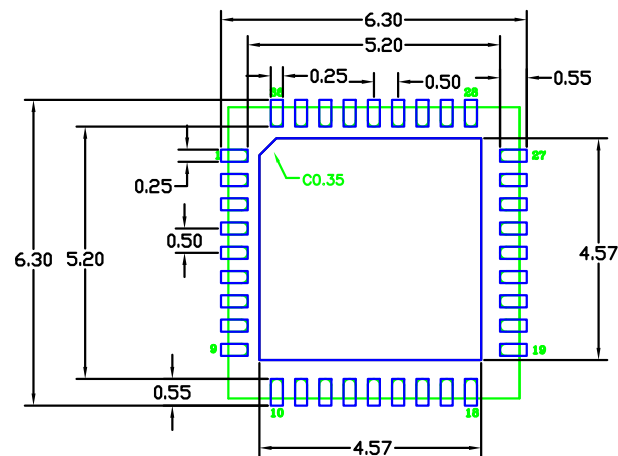

RECOMMENDED LAND PATTERN DIMENSION

NOTES:

1. ALL DIMENSIONS ARE IN MM. ANGLES IN DEGREES.
2. TOP DOWN VIEW, AS VIEWED ON PCB.
3. COMPONENT OUTLINE SHOWS FOR REFERENCE IN GREEN.
4. LAND PATTERN IN BLUE. NSMD PATTERN ASSUMED.
5. LAND PATTERN RECOMMENDATION PER IPC-7351B GENERIC REQUIREMENT FOR SURFACE MOUNT DESIGN AND LAND PATTERN.

TOLERANCES UNLESS SPECIFIED		 www.IDT.com	6024 SILVER CREEK VALLEY ROAD, SAN JOSE, CA 95138 PHONE: (408) 284-8200 FAX: (408) 284-3572
DECIMAL	ANGULAR		
X± .1	±1°	TITLE NB/NBG36P3 PACKAGE OUTLINE	
XX± .05		6.0 x 6.0 mm BODY, EPAD 4.57 mm SQ	
XXX± .030		0.50 mm PITCH QFN	
SIZE	DRAWING No.	REV	
C	PSC-4311-03	01	
DO NOT SCALE DRAWING			SHEET 2 OF 2