

REVISIONS			
REV	DESCRIPTION	DATE	APPROVED
00	INITIAL RELEASE	02/4/16	JH

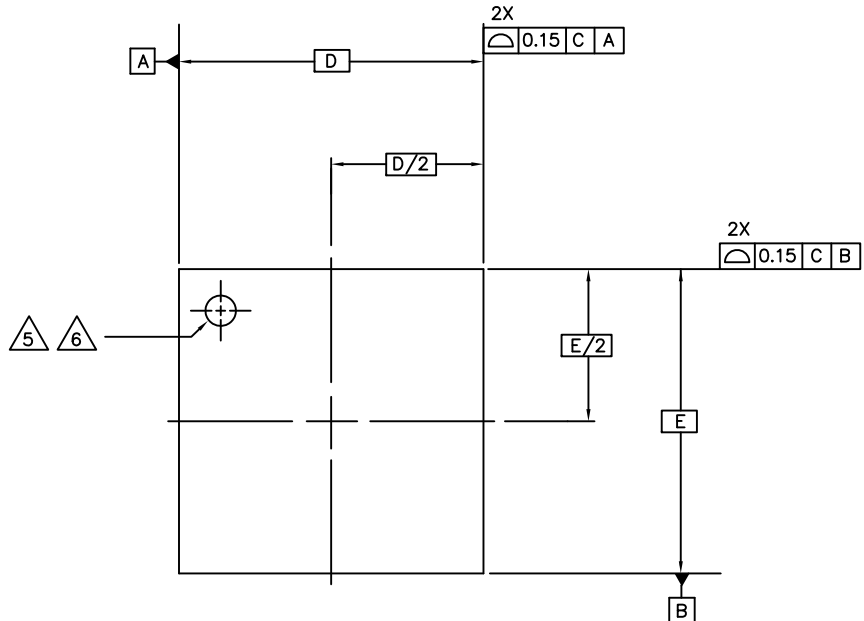

TOP VIEW

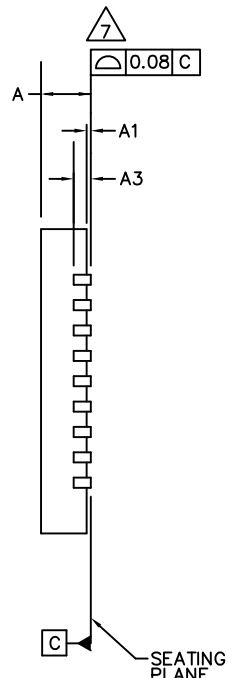

SIDE VIEW

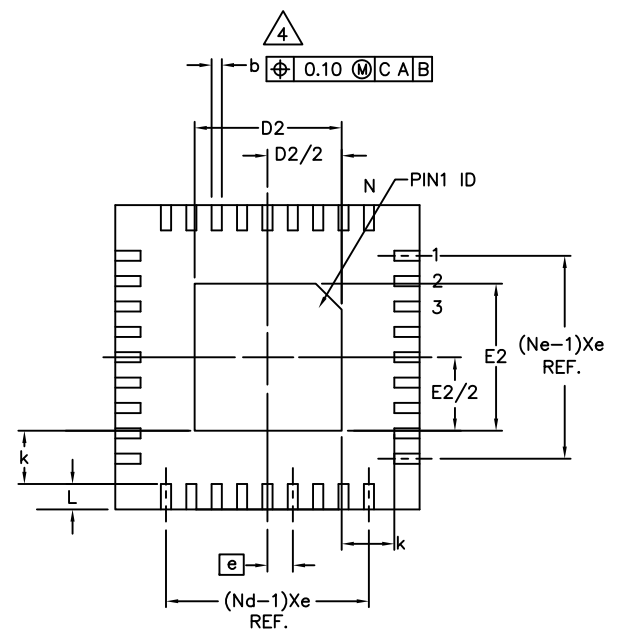

BOTTOM VIEW

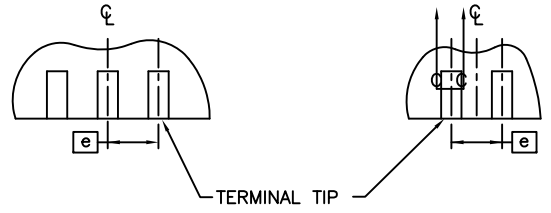

FOR ODD TERMINAL/SIDE

FOR EVEN TERMINAL/SIDE

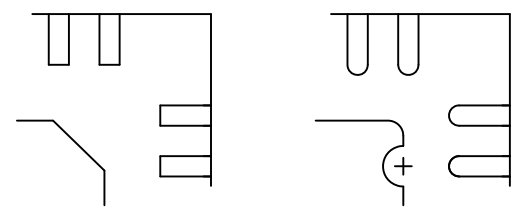
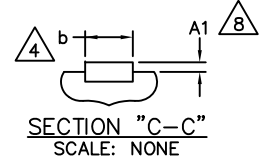

PIN #1 ID AND TIE BAR MARK OPTION

TOLERANCES UNLESS SPECIFIED		 6024 SILVERCREEK VALLEY ROAD SAN JOSE CA 95138 PHONE: (408) 284-8200 FAX: (408) 284-8591 www.IDT.com
DECIMAL	ANGULAR	
XX±	±	
XXX±		
XXXX±		
APPROVALS	DATE	TITLE
DRAWN <i>RAC</i>	02/4/16	NL/NLG 40 PACKAGE OUTLINE 6.0 X 6.0 mm BODY EPAD 2.90 x 2.90 mm QFN
CHECKED		
	SIZE	DRAWING No.
	C	PSC-4115-01
		REV
		00
DO NOT SCALE DRAWING		SHEET 1 OF 3

REVISIONS			
REV	DESCRIPTION	DATE	APPROVED
00	INITIAL RELEASE	02/4/16	JH

NOTES:

1. DIMENSIONING & TOLERANCING CONFORM TO ASME Y14.5M. – 1994.
2. N IS THE NUMBER OF TERMINALS.
Nd IS THE NUMBER OF TERMINALS IN X-DIRECTION &
Ne IS THE NUMBER OF TERMINALS IN Y-DIRECTION.
3. ALL DIMENSIONS ARE IN MILLIMETERS.
4. DIMENSION b APPLIES TO PLATED TERMINAL AND IS MEASURED BETWEEN 0.20 AND 0.30mm FROM TERMINAL TIP.
5. THE PIN #1 IDENTIFIER MUST EXIST ON THE TOP SURFACE OF THE PACKAGE BY USING INDENTATION MARK OR OTHER FEATURE OF PACKAGE BODY.
6. EXACT SHAPE AND SIZE OF THIS FEATURE IS OPTIONAL.
7. APPLIED TO EXPOSED PAD AND TERMINALS. EXCLUDE EMBEDDED PART OF EXPOSED PAD FROM MEASURING.
8. APPLIED ONLY FOR TERMINALS.
9. THIS OUTLINES CONFORMS TO JEDEC PUBLICATION 95 REGISTRATION MO-220, VARIATION VJJC-3 & VJJD-5 WITH THE EXCEPTION OF D2 & E2.

SYMBOL	DIMENSION			NOTE
	MIN	NOM	MAX	
b	0.18	0.25	0.30	4
D	6.00 BSC			
E	6.00 BSC			
D2	2.80	2.90	3.00	
E2	2.80	2.90	3.00	
L	0.30	0.40	0.50	
e	0.50 BSC			
k	1.15 REF.			
N	40			2
A	0.80	0.90	1.00	
A1	0.00	0.02	0.05	7
A3	0.2 REF			
Nd	10			2
Ne	10			2

TOLERANCES UNLESS SPECIFIED		 www.IDT.com	6024 SILVERCREEK VALLEY ROAD SAN JOSE CA, 95138 PHONE: (408) 284-8200 FAX: (408) 284-8591	
DECIMAL	ANGULAR			
XX±	±			
XXX±				
XXXX±				
APPROVALS	DATE	TITLE		
DRAWN <i>RdC</i>	02/4/16	NL/NLG 40 PACKAGE OUTLINE		
CHECKED		6.0 X 6.0 mm BODY		
		EPAD 2.90 x 2.90 mm QFN		
		SIZE	DRAWING No.	REV
		C	PSC-4115-01	00
DO NOT SCALE DRAWING				SHEET 2 OF 3

REVISIONS			
REV	DESCRIPTION	DATE	APPROVED
00	INITIAL RELEASE	02/4/16	JH

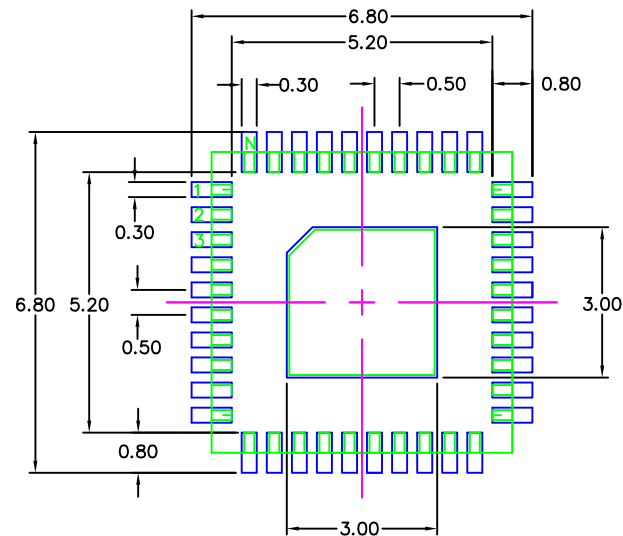
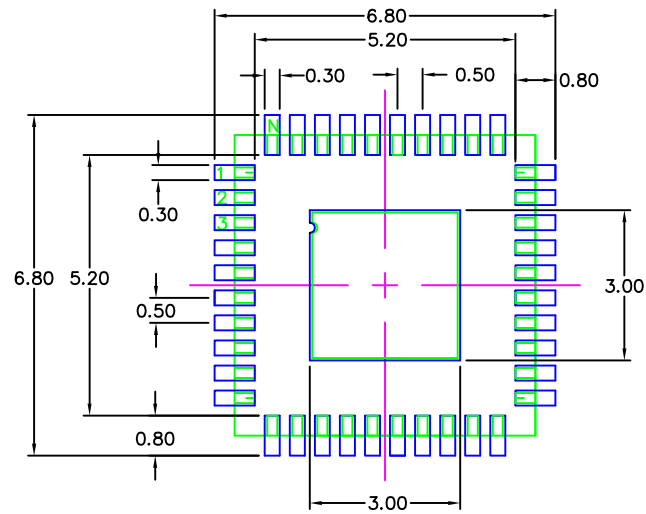

RECOMMENDED LAND PATTERN

NOTES:

1. ALL DIMENSIONS ARE IN mm. ANGLES IN DEGREES.
2. TOP DOWN VIEW. AS VIEWED ON PCB.
3. COMPONENT OUTLINE SHOWS FOR REFERENCE IN GREEN.
4. LAND PATTERN IN BLUE. NSMD PATTERN ASSUMED.
5. LAND PATTERN RECOMMENDATION PER IPC-7351B GENERIC REQUIREMENT FOR SURFACE MOUNT DESIGN AND LAND PATTERN.

TOLERANCES UNLESS SPECIFIED		 6024 SILVERCREEK VALLEY ROAD SAN JOSE CA, 95138 PHONE: (408) 284-8200 FAX: (408) 284-8591		
DECIMAL	ANGULAR			
XX±	±			
XXX±				
XXXX±				
APPROVALS	DATE	TITLE		
DRAWN <i>RAC</i>	02/4/16	NL/NLG 40 PACKAGE OUTLINE 6.0 X 6.0 mm BODY EPAD 2.90 x 2.90 mm QFN		
CHECKED				
		SIZE	DRAWING No.	REV
		C	PSC-4115-01	00
DO NOT SCALE DRAWING				SHEET 3 OF 3