

SAWN OPTION (Q1) PAGE 1 OF 2

DATE CREATED	REVISIONS		
	REV	DESCRIPTION	AUTHOR
12/5/12	00	INITIAL RELEASE.	RC
10/15/13	01	ORGANIZE SAWN AND PUNCH DWG	J.HUA
11/21/13	02	ADD EPAD OPTION	J.HUA
12/12/13	03	ADD LAND PATTERN DESCRIPTION	J.HUA
3/6/14	04	UPDATE "L" DIM on PUNCH' TO MATCH	J.HUA
3/2/17	05	ADD EPAD OPTION	J.HUA
5/2/17	06	CHANGE QFN to VFQFPN	J.HUA

NOTE: REFER TO DCP FOR OFFICIAL RELEASE DATE

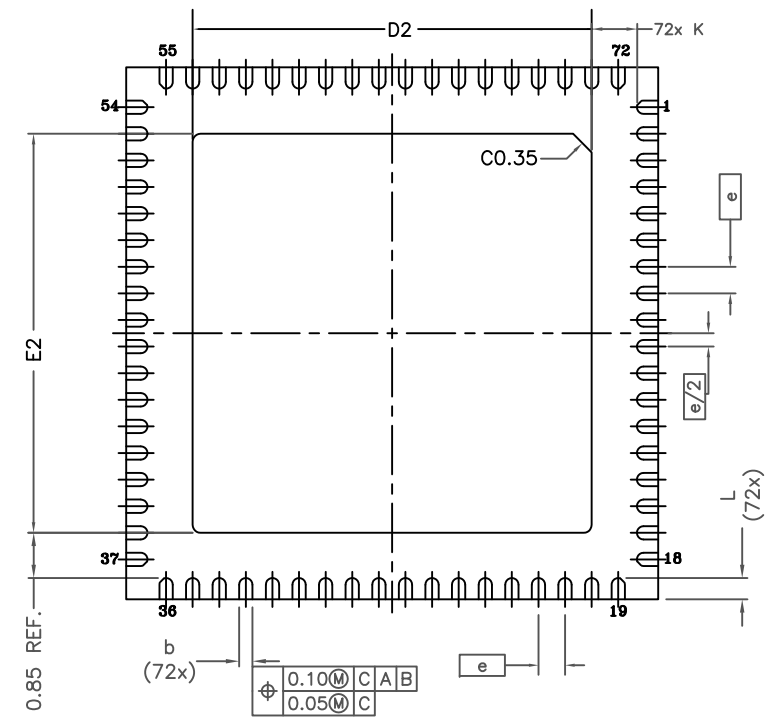
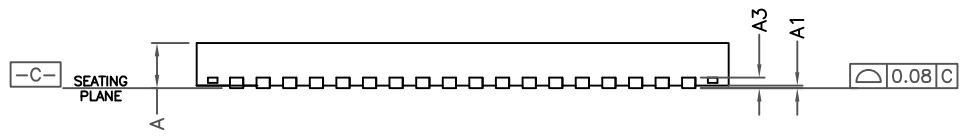
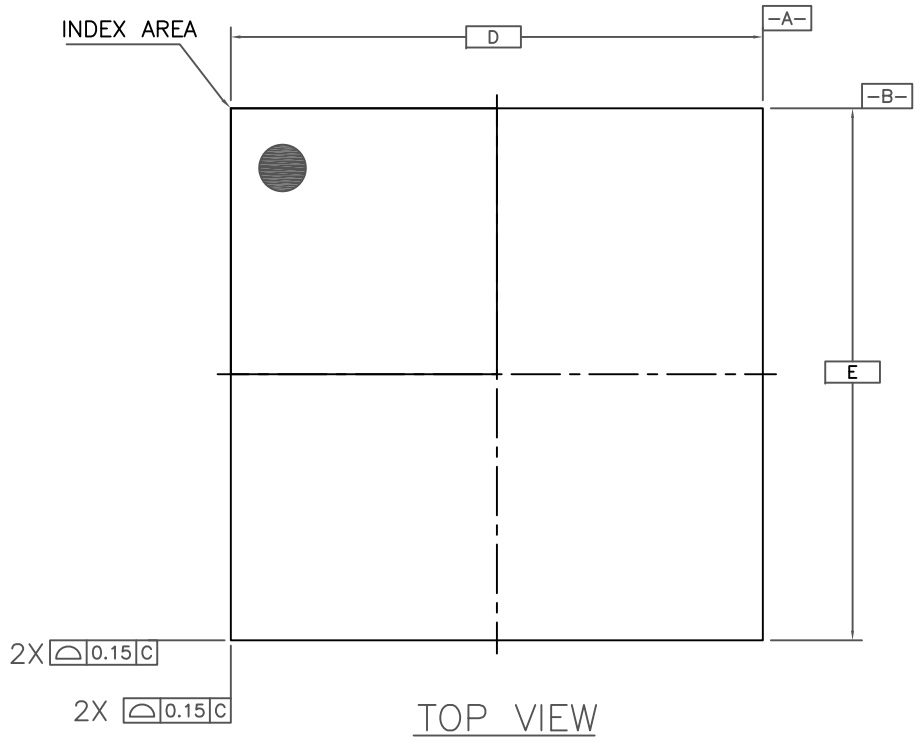

NOTES:

1. ALL DIMENSIONING AND TOLERANCING CONFORM TO ANSI Y14.5M-1994
2. ALL DIMENSIONS ARE IN MILLIMETERS.
3. INDEX AREA (PIN1 IDENTIFIER)

TOLERANCES UNLESS SPECIFIED DECIMAL ANGULAR X± XX± XXX±			6024 Silver Creek Valley Road San Jose, CA 95138 PHONE: (408) 284-8200 FAX: (408) 284-8591
	TITLE NL/NLG72 PACKAGE OUTLINE 10.0X10.0 mm BODY 0.50 mm Pitch VFQFPN		
SIZE C	DRAWING No. PSC-4208	REV 06	
DO NOT SCALE DRAWING		SHEET 1 OF 6	

SAWN OPTION (Q1) PAGE 2 OF 2

DATE CREATED	REV	REVISIONS	
		DESCRIPTION	AUTHOR
12/5/12	00	INITIAL RELEASE.	RC
10/15/13	01	ORGANIZE SAWN AND PUNCH DWG	J.HUA
11/21/13	02	ADD EPAD OPTION	J.HUA
12/12/13	03	ADD LAND PATTERN DESCRIPTION	J.HUA
3/6/14	04	UPDATE "L" DIM on PUNCH' TO MATCH	J.HUA
3/2/17	05	ADD EPAD OPTION	J.HUA
5/2/17	06	CHANGE QFN to VFQFPN	J.HUA

NOTE: REFER TO DCP FOR OFFICIAL RELEASE DATE

EPAD OPTION:

SYMBOL	DIMENSION			NOTE
	MIN.	NOM.	MAX.	
D2	SEE EPAD OPTION			
E2	SEE EPAD OPTION			
K	0.20	-	-	
A2	0.00	0.65	1.00	
L	0.30	0.40	0.50	
COMMON DIMENSIONS				
SYMBOL \ DIM	MIN	NOM	MAX	
A	0.80	0.90	1.00	
A1	0	0.02	0.05	
A3 REF	-	0.20 ref	-	
b	0.18	0.25	0.30	
Ⓢ	0.50 BSC			
D	10.00 BSC			
E	10.00 BSC			

SYMBOL	P1			P2			P3			P4		
	MIN.	NOM.	MAX.	MIN.	NOM.	MAX.	MIN.	NOM.	MAX.	MIN.	NOM.	MAX.
E2	5.80	5.90	6.00	7.40	7.50	7.60	8.30	8.40	8.50	7.60	7.70	7.80
D2	5.80	5.90	6.00	7.40	7.50	7.60	8.30	8.40	8.50	7.60	7.70	7.80

TOLERANCES UNLESS SPECIFIED DECIMAL ANGULAR X± XX± XXX±	 IDT™ www.IDT.com		6024 Silver Creek Valley Road San Jose, CA 95138 PHONE: (408) 284-8200 FAX: (408) 284-8591	
			TITLE NL/NLG72 PACKAGE OUTLINE 10.0X10.0 mm BODY 0.50 mm Pitch VFQFPN	
SIZE	DRAWING No.	REV		
C	PSC-4208	06		
DO NOT SCALE DRAWING			SHEET 2 OF 6	

PUNCH OPTION (Q2) PAGE 1 OF 3

DATE		REVISIONS	
CREATED	REV	DESCRIPTION	AUTHOR
12/5/12	00	INITIAL RELEASE.	RC
10/15/13	01	ORGANIZE SAWN AND PUNCH DWG	J.HUA
11/21/13	02	ADD EPAD OPTION	J.HUA
12/12/13	03	ADD LAND PATTERN DESCRIPTION	J.HUA
3/6/14	04	UPDATE "L" DIM on PUNCH' TO MATCH	J.HUA
3/2/17	05	ADD EPAD OPTION	J.HUA
5/2/17	06	CHANGE QFN to VFQFPN	J.HUA

NOTE: REFER TO DCP FOR OFFICIAL RELEASE DATE

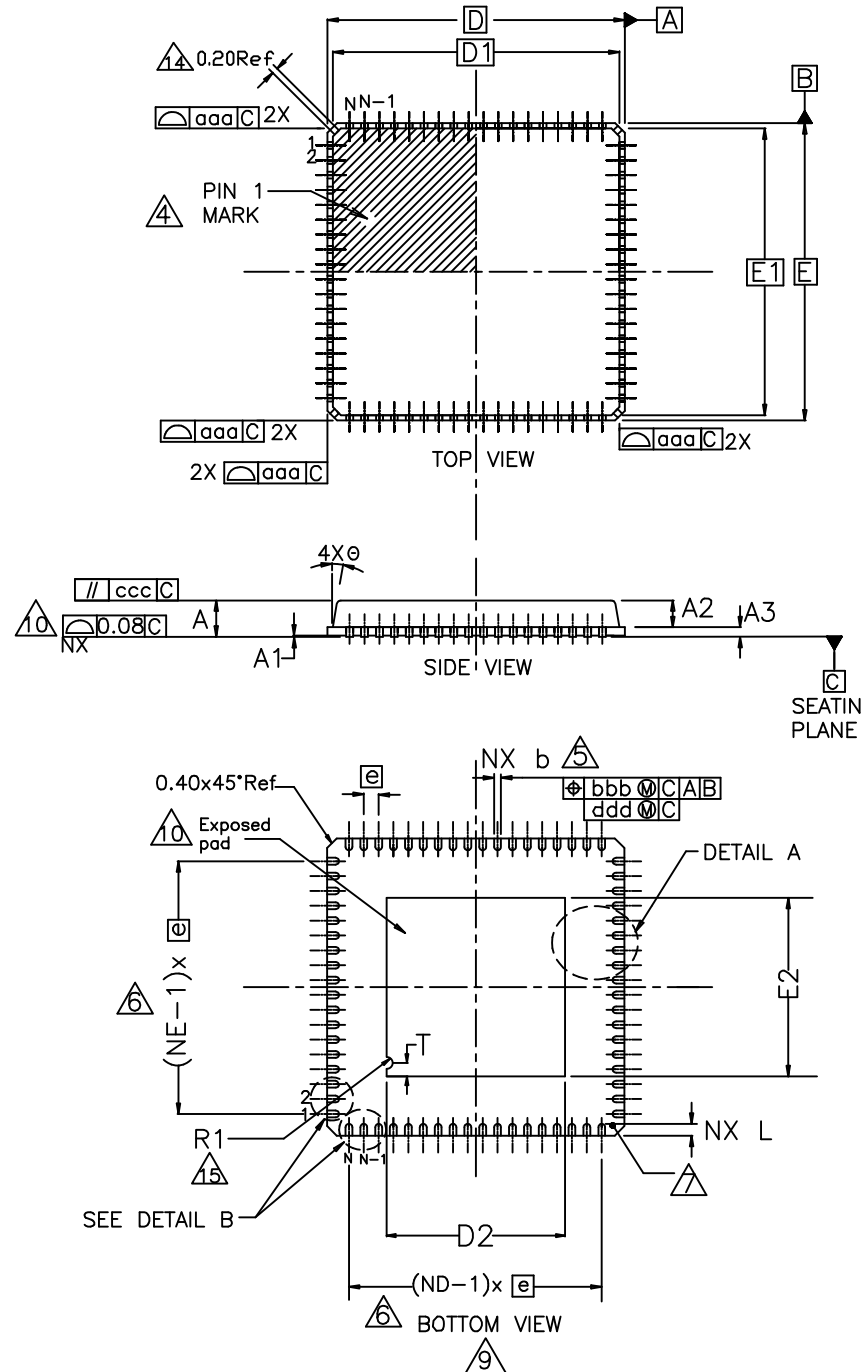

TOLERANCES
UNLESS SPECIFIED
DECIMAL ANGULAR
X±
XX±
XXX±



6024 Silver Creek Valley Road
San Jose, CA 95138
PHONE: (408) 284-8200
FAX: (408) 284-8591

TITLE NL/NLG72 PACKAGE OUTLINE
10.0X10.0 mm BODY
0.50 mm Pitch VFQFPN

SIZE	DRAWING No.	REV
C	PSC-4208	06

DO NOT SCALE DRAWING

SHEET 3 OF 6

DATE CREATED		REVISIONS		AUTHOR
REV	DESCRIPTION			
12/5/12	00	INITIAL RELEASE.		RC
10/15/13	01	ORGANIZE SAWN AND PUNCH DWG		J.HUA
11/21/13	02	ADD EPAD OPTION		J.HUA
12/12/13	03	ADD LAND PATTERN DESCRIPTION		J.HUA
3/6/14	04	UPDATE "L" DIM on PUNCH' TO MATCH		J.HUA
3/2/17	05	ADD EPAD OPTION		J.HUA
5/2/17	06	CHANGE QFN to VFQFPN		J.HUA
NOTE: REFER TO DCP FOR OFFICIAL RELEASE DATE				

PUNCH OPTION (Q2) PAGE 2 OF 3

EPAD OPTION:

SYMBOL	DIMENSION			NOTE
	MIN.	NOM.	MAX.	
D2	SEE EPAD OPTION			
E2	SEE EPAD OPTION			
k	0.20	-	-	
N		72		3
Nd		18		6
Ne		18		6
A2	0.00	0.65	1.00	
L	0.30	0.40	0.50	

SYMBOL	P1		
	MIN.	NOM.	MAX.
E2	5.80	5.90	6.00
D2	5.80	5.90	6.00

COMMON DIMENSIONS

SYMBOL \ DIM	MIN	NOM	MAX
A	0.80	0.90	1.00
A1	0	0.02	0.05
D1	9.75 BSC		
E1	9.75 BSC		
A3 REF	-	0.20 ref	-
θ	0	-	14
T ref.	-	0.45	-
R1	-	0.20	-
R ref. b min/2			
NOTES		1,2	
b	0.18	0.25	0.30
⊖	0.50 BSC		
D	10.00 BSC		
E	10.00 BSC		

TOLERANCE OF FORM & POSITION	
aaa	0.15
bbb	0.10
ccc	0.10
ddd	0.05
NOTES	1,2

NOTES:

- DIMENSIONING & TOLERANCING CONFORM TO ASME Y14.5M-1994.
- ALL DIMENSIONS ARE IN MILLIMETERS. ANGLES ARE IN DEGREES.
- N IS THE TOTAL NUMBER OF TERMINALS.
Nd IS THE NUMBER OF TERMINALS IN X-DIRECTION &
Ne IS THE NUMBER OF TERMINALS IN Y-DIRECTION.
- THE TERMINAL #1 IDENTIFIER AND TERMINAL NUMBERING CONVENTION SHALL CONFORM TO JEDEC PUB. 95 SEC. 4.3 SPP-002. DETAILS OF TERMINAL #1 IDENTIFIER ARE OPTIONAL, BUT MUST BE LOCATED WITHIN THE ZONE INDICATED. THE TERMINAL #1 IDENTIFIER MAY BE EITHER A MOLD OR MARKED FEATURE.
- DIMENSION b APPLIES TO METALLIZED TERMINAL AND IS MEASURED BETWEEN 0.25mm AND 0.30mm FROM TERMINAL TIP.
- ND AND NE REFER TO THE NUMBER OF TERMINALS ON EACH D AND E SIDE RESPECTIVELY.
- DEPOPULATION IS POSSIBLE IN A SYMMETRICAL FASHION.

TOLERANCES UNLESS SPECIFIED DECIMAL ANGULAR X± XX± XXX±	 IDT™ 6024 Silver Creek Valley Road San Jose, CA 95138 PHONE: (408) 284-8200 www.IDT.com FAX: (408) 284-8591	
TITLE NL/NLG72 PACKAGE OUTLINE 10.0X10.0 mm BODY 0.50 mm Pitch VFQFPN		
SIZE C	DRAWING No. PSC-4208	REV 06
DO NOT SCALE DRAWING		SHEET 4 OF 6

PUNCH OPTION (Q2) PAGE 3 OF 3

DATE CREATED	REV	REVISIONS	
		DESCRIPTION	AUTHOR
12/5/12	00	INITIAL RELEASE.	RC
10/15/13	01	ORGANIZE SAWN AND PUNCH DWG	J.HUA
11/21/13	02	ADD EPAD OPTION	J.HUA
12/12/13	03	ADD LAND PATTERN DESCRIPTION	J.HUA
3/6/14	04	UPDATE "L" DIM on PUNCH' TO MATCH	J.HUA
3/2/17	05	ADD EPAD OPTION	J.HUA
5/2/17	06	CHANGE QFN to VQFPN	J.HUA

NOTE: REFER TO DCP FOR OFFICIAL RELEASE DATE

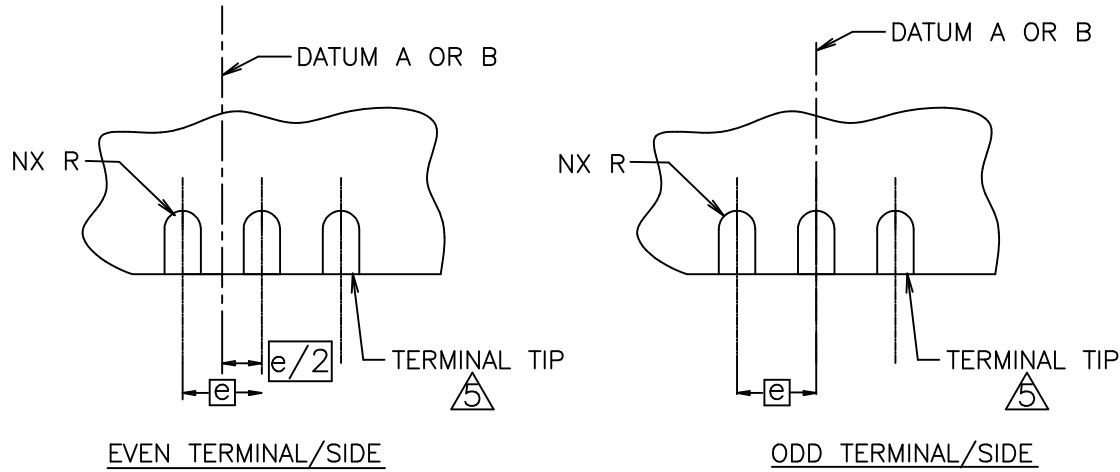

DETAIL B

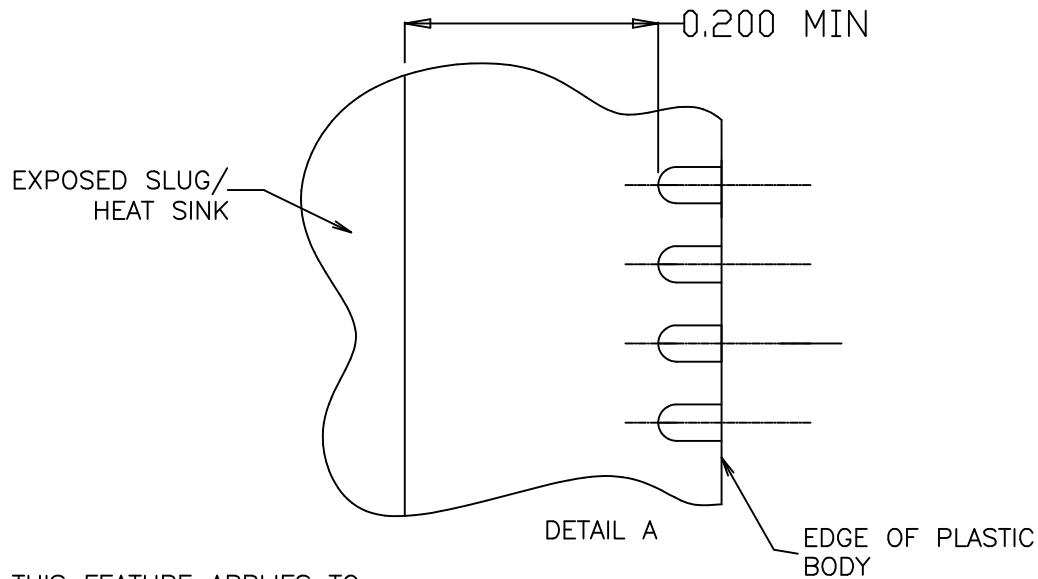

THIS FEATURE APPLIES TO ALL ENDS OF THE PKG.

TOLERANCES
UNLESS SPECIFIED
DECIMAL ANGULAR
X±
XX±
XXX±



6024 Silver Creek Valley Road
San Jose, CA 95138
PHONE: (408) 284-8200
FAX: (408) 284-8591

TITLE NL/NLG72 PACKAGE OUTLINE
10.0X10.0 mm BODY
0.50 mm Pitch VQFPN

SIZE C	DRAWING No. PSC-4208	REV 06
------------------	-------------------------	-----------

DO NOT SCALE DRAWING

SHEET 5 OF 6

SAWN LAND PATTERN

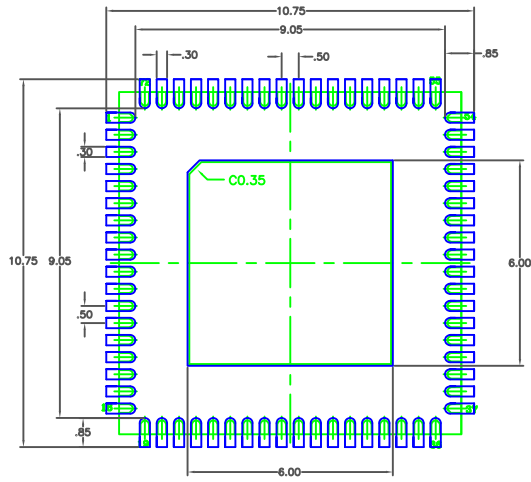

P1 EPAD 5.9 mm SQ

SAWN LAND PATTERN

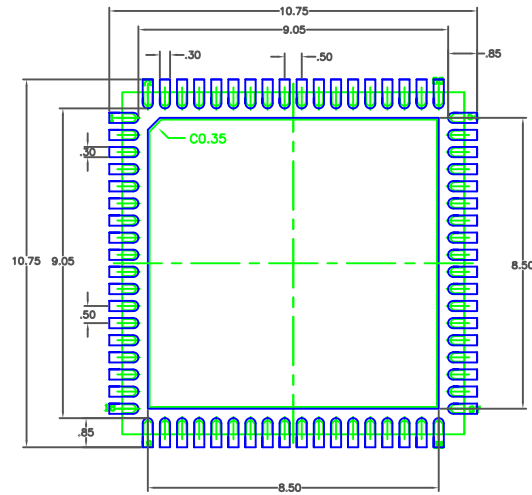

P3 EPAD 8.4 mm SQ

SAWN LAND PATTERN

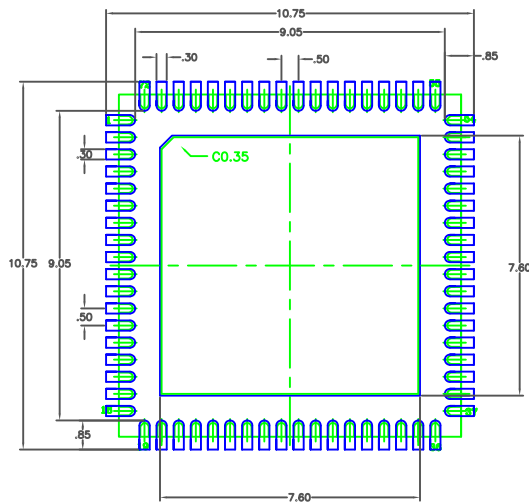

P2 EPAD 7.5 mm SQ

SAWN LAND PATTERN

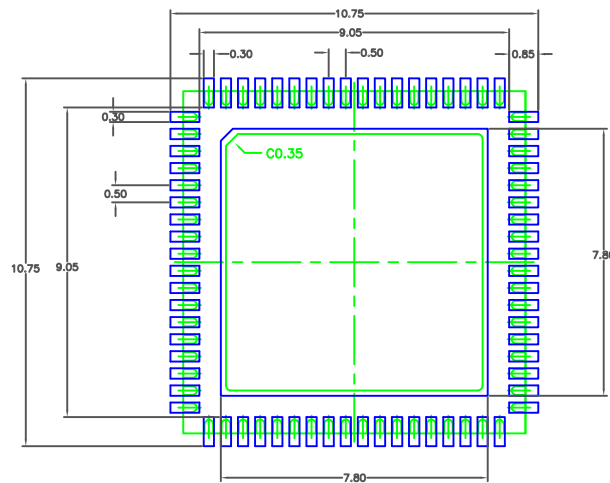

P4 EPAD 7.7 mm SQ

PUNCH LAND PATTERN

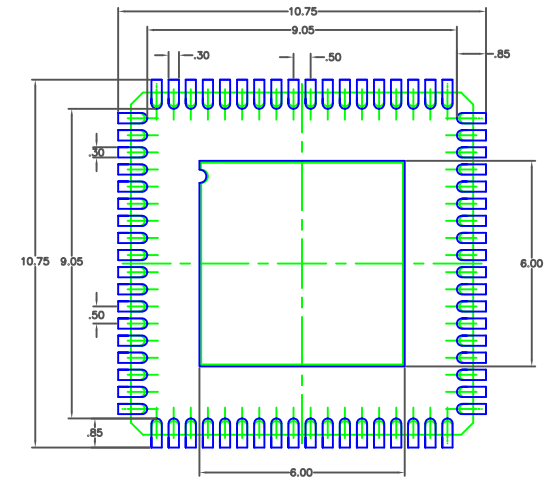

P1 EPAD 5.9 mm SQ

DATE CREATED	REVISIONS		
	REV	DESCRIPTION	AUTHOR
12/5/12	00	INITIAL RELEASE.	RC
10/15/13	01	ORGANIZE SAWN AND PUNCH DWG	J.HUA
11/21/13	02	ADD EPAD OPTION	J.HUA
12/12/13	03	ADD LAND PATTERN DESCRIPTION	J.HUA
3/6/14	04	UPDATE "L" DIM on "PUNCH" TO MATCH	J.HUA
3/2/17	05	ADD EPAD OPTION	J.HUA
5/2/17	06	CHANGE QFN to VFQFPN	J.HUA

NOTE: REFER TO DCP FOR OFFICIAL RELEASE DATE

RECOMMENDED LAND PATTERN DIMENSION

NOTES:

1. ALL DIMENSION ARE IN mm. ANGLES IN DEGREES.
2. TOP DOWN VIEW, AS VIEWED ON PCB.
3. COMPONENT OUTLINE SHOW FOR REFERENCE IN GREEN.
4. LAND PATTERN IN BLUE. NSMD PATTERN ASSUMED.
5. LAND PATTERN RECOMMENDATION PER IPC-7351B GENERIC REQUIREMENT FOR SURFACE MOUNT DESIGN AND LAND PATTERN.

TOLERANCES UNLESS SPECIFIED DECIMAL ANGULAR X± XX± XXX±		 6024 Silver Creek Valley Road San Jose, CA 95138 PHONE: (408) 284-8200 FAX: (408) 284-8591 www.IDT.com
TITLE NL/NLG72 PACKAGE OUTLINE 10.0X10.0 mm BODY 0.50 mm Pitch VFQFPN		
SIZE	DRAWING No.	REV
C	PSC-4208	06
DO NOT SCALE DRAWING		SHEET 6 OF 6