

Brief Description

The ZSSC1750 and ZSSC1751 are System Basis Chips (SBCs) with a dual-channel ADC for battery sensing/management in automotive, industrial, and medical systems. The ZSSC1750 and ZSSC1751 feature an SPI interface; in addition, the ZSSC1750 has an integrated LIN 2.1 transceiver.

One of the two input channels measures the battery current I_{BAT} via the voltage drop at the external shunt resistor. The second channel measures the battery voltage V_{BAT} and the temperature.

By simultaneously measuring V_{BAT} and I_{BAT} , it is possible to determine dynamically the internal resistance of the battery, R_{di} , which is correlated with the state-of-health (SOH) of the battery. By integrating I_{BAT} , it is possible to determine the state-of-charge (SOC) and the state-of-function (SOF) of the battery.

During Sleep Mode, the system makes periodic measurements to monitor the discharge of the battery. Measurement cycles are controlled by user software and include various wake-up conditions. The ZSSC1750/51 is optimized for ultra-low power consumption drawing only 60 μ A or less in this mode.

Features

- Two high-precision 24-bit sigma-delta ADCs (18-bit with no missing codes); sample rate: 1Hz to 16kHz
- On-chip voltage reference (5ppm/K typical)
- Current channel
 - I_{BAT} offset error: ≤ 10 mA
 - I_{BAT} resolution: ≤ 1 mA
 - Programmable gain: 4 to 512
 - Max. differential input stage input range: ± 300 mV
- Voltage channel
 - Input range: 4 to 28.8V
 - Voltage accuracy: ± 60 ppm FSR* = 1.73mV
- Temperature channel
 - External temperature sensor (NTC)
 - Factory-calibrated internal temp. sensor: ± 2 $^{\circ}$ C
- LIN 2.1/SAE J2602-1 transceiver (ZSSC1750 only)
- Typical current consumption
 - Normal Mode: 12mA
 - Sleep Mode: ≤ 60 μ A

Benefits

- Integrated, precision measurement solution for accurate prediction of battery state of health (SOH), state of charge (SOC), or state of function (SOF)
- Robust power-on-reset (POR) concept for harsh automotive environments
- On-chip precision oscillator accuracy: $\pm 1\%$
- On-chip low-power oscillator
- Only a few external components needed
- Easy communication via SPI interface
- Power supply, interrupt, and reset signals for external microcontroller
- Watchdog timer with dedicated oscillator
- Industry's smallest footprint allows minimal module size and cost
- AEC-Q100 qualified solution

Available Support

- Evaluation Kit
- Application Notes

Physical Characteristics

- Operation temperature up to -40° C to $+125^{\circ}$ C
- Supply voltage: 4.2 to 18V
- Small footprint package: PQFN36 6x6 mm

* FSR = full-scale range.

Basic ZSSC1750/51 Application Circuit

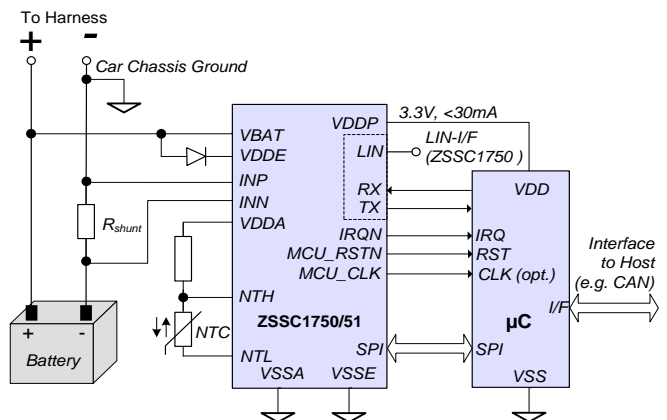

ZSSC1750/51 Block Diagram

Applications

- Intelligent battery monitoring in automotive applications; start/stop systems, e-bikes, scooters, and e-carts
- Battery monitoring in Industrial, medical and photovoltaic applications;
- High precision data acquisition

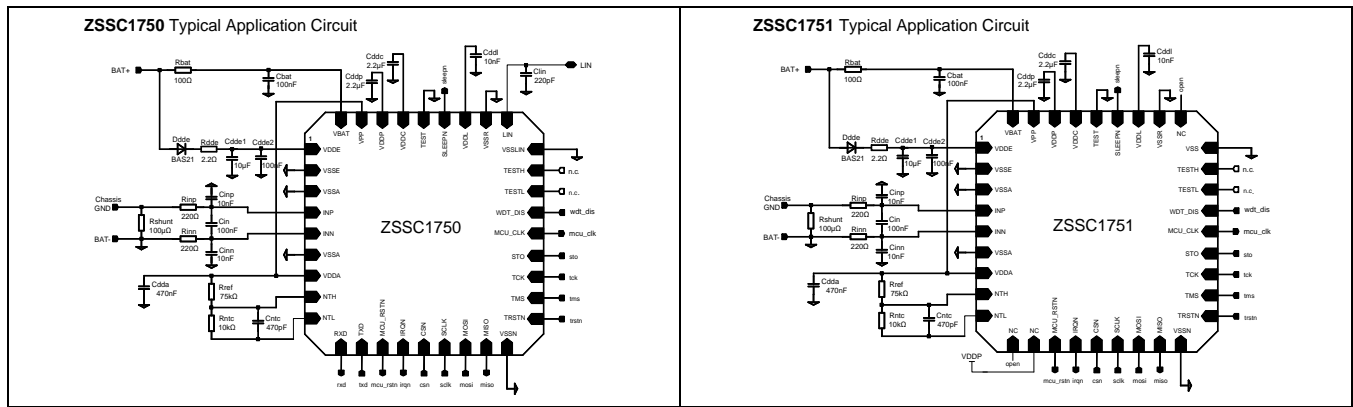
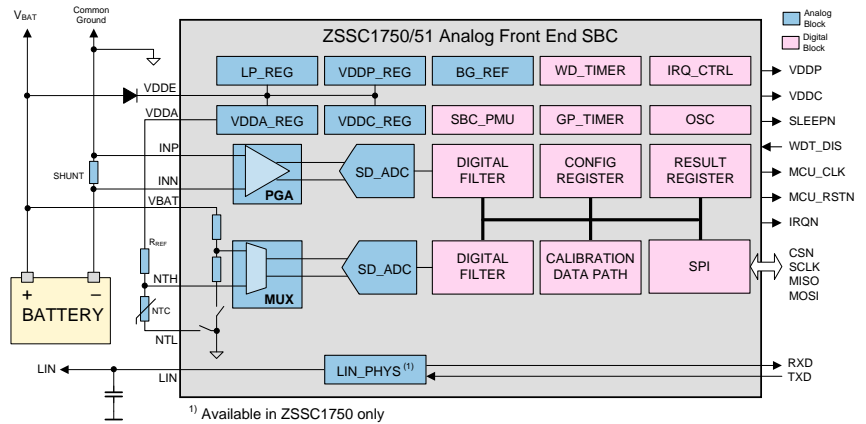

Ordering Information

Product Sales Code	Description	Package
ZSSC1750EA3R	ZSSC1750 Battery Sensing SBC—Temperature Range: -40°C to 125°C	PQFN36 6x6 mm, reel
ZSSC1751EA3R	ZSSC1751 Battery Sensing SBC—Temperature Range: -40°C to 125°C	PQFN36 6x6 mm, reel
ZSSC1750KIT V1.1	ZSSC1750/51 Evaluation Kit: modular evaluation and development board for ZSSC1750/51, 3 IC samples, and USB cable (software and documentation can be downloaded from www.IDT.com)	



Corporate Headquarters
6024 Silver Creek Valley Road
San Jose, CA 95138
www.IDT.com

Sales
1-800-345-7015 or 408-284-8200
Fax: 408-284-2775
www.IDT.com/go/sales

Tech Support
www.IDT.com/go/support

DISCLAIMER Integrated Device Technology, Inc. (IDT) reserves the right to modify the products and/or specifications described herein at any time, without notice, at IDT's sole discretion. Performance specifications and operating parameters of the described products are determined in an independent state and are not guaranteed to perform the same way when installed in customer products. The information contained herein is provided without representation or warranty of any kind, whether express or implied, including, but not limited to, the suitability of IDT's products for any particular purpose, an implied warranty of merchantability, or non-infringement of the intellectual property rights of others. This document is presented only as a guide and does not convey any license under intellectual property rights of IDT or any third parties.

IDT's products are not intended for use in applications involving extreme environmental conditions or in life support systems or similar devices where the failure or malfunction of an IDT product can be reasonably expected to significantly affect the health or safety of users. Anyone using an IDT product in such a manner does so at their own risk, absent an express, written agreement by IDT.

Integrated Device Technology, IDT and the IDT logo are trademarks or registered trademarks of IDT and its subsidiaries in the United States and other countries. Other trademarks used herein are the property of IDT or their respective third party owners. For datasheet type definitions and a glossary of common terms, visit www.idt.com/go/glossary. All contents of this document are copyright of Integrated Device Technology, Inc. All rights reserved.