

### General Description

The IDT1338B-31 is a serial real-time clock (RTC) device that consumes ultra-low power and provides a full binary-coded decimal (BCD) clock/calendar with 56 bytes of battery backed Non-Volatile Static RAM. The clock/calendar provides seconds, minutes, hours, day, date, month, and year information. The clock operates in either the 24-hour or 12-hour format with AM/PM indicator. The end of the month date is automatically adjusted for months with fewer than 31 days, including corrections for leap year. Access to the clock/calendar registers is provided by an I<sup>2</sup>C interface capable of operating in fast I<sup>2</sup>C mode. Built-in Power-sense circuitry detects power failures and automatically switches to the backup supply, maintaining time and date operation.

### Applications

- Telecom (Routers, Switches, Servers)
- Handheld (GPS, Point of Sale POS terminals)
- Consumer Electronics (Set-Top Box, Digital Recording, Network Applications, Digital photo frames)
- Office (Fax/Printers, Copiers)
- Medical (Glucometer, Medicine Dispensers)

### Block Diagram

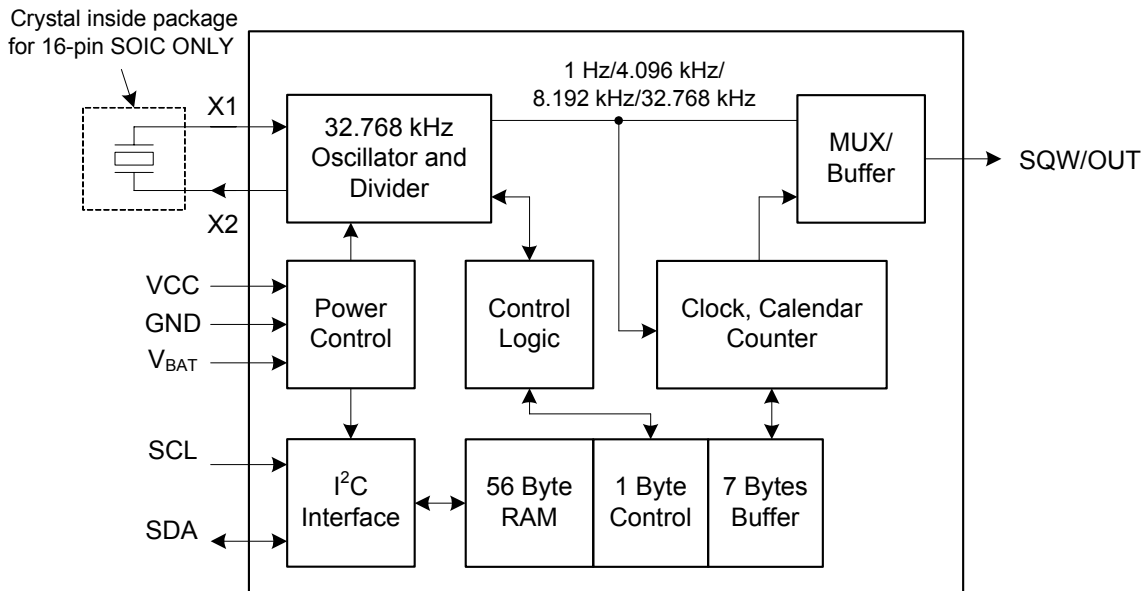

- Others (Thermostats, Vending Machines, Modems, Utility Meters)

### Features

- Real-Time Clock (RTC) counts seconds, minutes, hours, day, date, month, and year with leap-year compensation valid up to 2100
- 56-Byte battery-backed Non Volatile RAM for data storage
- Fast mode I<sup>2</sup>C Serial interface
- Automatic power-fail detect and switch circuitry
- Programmable square-wave output
- Packaged in 8-pin MSOP, 8-pin SOIC, or 16-pin SOIC (surface-mount package with an integrated crystal)
- Industrial temperature range (-40°C to +85°C)

## Pin Assignment (8-pin MSOP/8-pin SOIC)

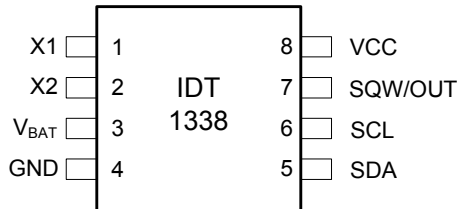

## Pin Assignment (16-pin SOIC)

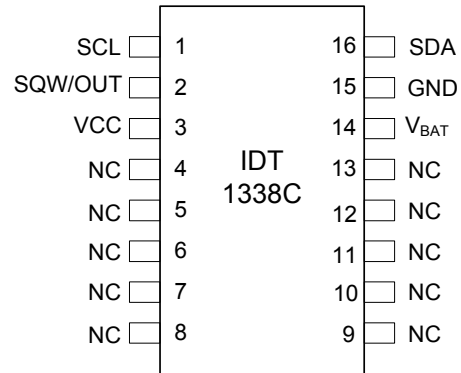

## Pin Descriptions

Pin Number		Pin Name	Pin Description/Function
8MSOP, 8SOIC	16SOIC		
1	—	X1	Connections for standard 32.768 kHz quartz crystal. The internal oscillator circuitry is designed for operation with a crystal having a specified load capacitance (CL) of 12.5 pF. An external 32.768 kHz oscillator can also drive the IDT1338B-31. In this configuration, the X1 pin is connected to the external oscillator signal and the X2 pin is left floating.
2	—	X2	
3	14	V <sub>BAT</sub>	Backup Supply Input for Lithium Coin Cell or Other Energy Source. Battery voltage must be held between the minimum and maximum limits for proper operation. Diodes placed in series between the backup source and the V <sub>BAT</sub> pin may prevent proper operation. If a backup supply is not required, V <sub>BAT</sub> must be connected to ground.
4	15	GND	Connect to ground.
5	16	SDA	Serial data input/output. SDA is the input/output pin for the I <sup>2</sup> C serial interface. It is an open-drain output and requires an external pull-up resistor (2 Kohm typical).
6	1	SCL	Serial clock input. SCL is used to synchronize data movement on the serial interface. It is an open-drain output and requires an external pull-up resistor (2 Kohm typical)
7	2	SQW/OUT	Square-Wave/Output driver. When enabled and the SQWE bit set to 1, the SQW/OUT pin outputs one of four square-wave frequencies (1 Hz, 4 kHz, 8 kHz, 32 kHz). It is an open drain output and requires an external pull-up resistor (10K ohm typical). Operates when the device is powered with VCC or V <sub>BAT</sub> .
8	3	V <sub>CC</sub>	Device power supply. When voltage is applied within specified limits, the device is fully accessible by I <sup>2</sup> C and data can be written and read.
—	4 - 13	NC	No connect. These pins are unused and must be connected to ground for proper operation.

## Typical Operating Circuit

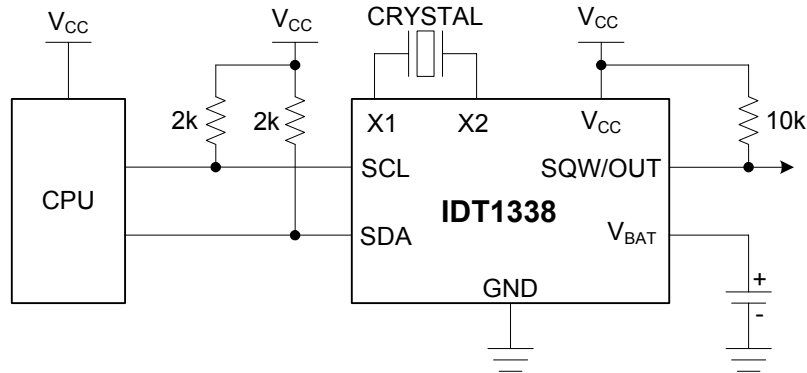

## Detailed Description

The following sections discuss in detail the Oscillator block, Power Control block, Clock/Calendar Register Block and Serial I<sup>2</sup>C block.

### Oscillator Block

Selection of the right crystal, correct load capacitance and careful PCB layout are important for a stable crystal oscillator. Due to the optimization for the lowest possible current in the design for these oscillators, losses caused by parasitic currents can have a significant impact on the overall oscillator performance. Extra care needs to be taken to maintain a certain quality and cleanliness of the PCB.

### Crystal Selection

The key parameters when selecting a 32 kHz crystal to work with IDT1338 RTC are:

- Recommended Load Capacitance
- Crystal Effective Series Resistance (ESR)
- Frequency Tolerance

### Effective Load Capacitance

Please see diagram below for effective load capacitance calculation. The effective load capacitance (CL) should match the recommended load capacitance of the crystal in order for the crystal to oscillate at its specified parallel resonant frequency with 0ppm frequency error.

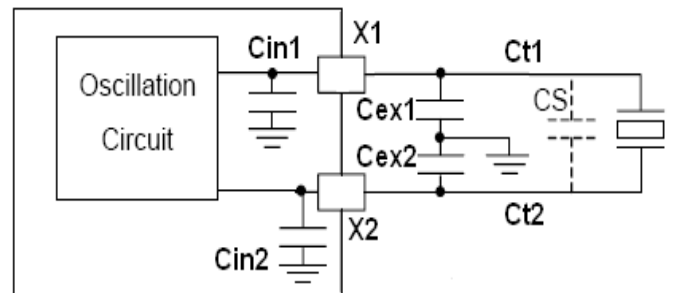

$$CL = CS + ((CX1 * CX2) / (CX1 + CX2))$$

$$CX1 = (Cin1 + Cex1 + Ct1)$$

$$CX2 = (Cin2 + Cex2 + Ct2)$$

In the above figure, X1 and X2 are the crystal pins of our device. Cin1 and Cin2 are the internal capacitors which include the X1 and X2 pin capacitance. Cex1 and Cex2 are the external capacitors that are needed to tune the crystal frequency. Ct1 and Ct2 are the PCB trace capacitances between the crystal and the device pins. CS is the shunt capacitance of the crystal (as specified in the crystal manufacturer's datasheet or measured using a network analyzer).

**Note:** IDT1338CSRI integrates a standard 32.768 kHz crystal in the package and contributes an additional frequency error of 10ppm at nominal V<sub>CC</sub> (+3.3 V) and T<sub>A</sub>=+25°C.

### ESR (Effective Series Resistance)

Choose the crystal with lower ESR. A low ESR helps the crystal to start up and stabilize to the correct output frequency faster compared to high ESR crystals.

### Frequency Tolerance

The frequency tolerance for 32 KHz crystals should be specified at nominal temperature (+25°C) on the crystal manufacturer datasheet. The crystals used with IDT1338 typically have a frequency tolerance of +/-20ppm at +25°C.

Specifications for a typical 32kHz crystal used with our device are shown in the table below.

Parameter	Symbol	Min	Typ	Max	Units
Nominal Freq.	$f_O$		32.768		kHz
Series Resistance	ESR			50	k $\Omega$
Load Capacitance	$C_L$		12.5		pF

### PCB Design Consideration

- Signal traces between IDT device pins and the crystal must be kept as short as possible. This minimizes parasitic capacitance and sensitivity to crosstalk and EMI. Note that the trace capacitances play a role in the effective crystal load capacitance calculation.
- Data lines and frequently switching signal lines should be routed as far away from the crystal connections as possible. Crosstalk from these signals may disturb the oscillator signal.
- Reduce the parasitic capacitance between X1 and X2 signals by routing them as far apart as possible.
- The oscillation loop current flows between the crystal and the load capacitors. This signal path (crystal to CL1 to CL2 to crystal) should be kept as short as possible and ideally be symmetric. The ground connections for both capacitors should be as close together as possible. Never route the ground connection between the capacitors all around the crystal, because this long ground trace is sensitive to crosstalk and EMI.
- To reduce the radiation / coupling from oscillator circuit, an isolated ground island on the GND layer could be made. This ground island can be connected at one point to the GND layer. This helps to keep noise generated by

the oscillator circuit locally on this separated island. The ground connections for the load capacitors and the oscillator should be connected to this island.

### PCB Layout



### PCB Assembly, Soldering and Cleaning

Board-assembly production process and assembly quality can affect the performance of the 32 KHz oscillator. Depending on the flux material used, the soldering process can leave critical residues on the PCB surface. High humidity and fast temperature cycles that cause humidity condensation on the printed circuit board can create process residuals. These process residuals cause the insulation of the sensitive oscillator signal lines towards each other and neighboring signals on the PCB to decrease. High humidity can lead to moisture condensation on the surface of the PCB and, together with process residuals, reduce the surface resistivity of the board. Flux residuals on the board can cause leakage current paths, especially in humid environments. Thorough PCB cleaning is therefore highly recommended in order to achieve maximum performance by removing flux residuals from the board after assembly. In general, reduction of losses in the oscillator circuit leads to better safety margin and reliability.

## Power Control

A precise, temperature-compensated voltage reference and a comparator circuit provides power-control function that monitors the  $V_{CC}$  level. The device is fully accessible and data can be written and read when  $V_{CC}$  is greater than  $V_{PF}$ . However, when  $V_{CC}$  falls below  $V_{PF}$  the internal clock registers are blocked from any access. If  $V_{PF}$  is less than  $V_{BAT}$ , the device power is switched from  $V_{CC}$  to  $V_{BAT}$  when  $V_{CC}$  drops below  $V_{PF}$ . If  $V_{PF}$  is greater than  $V_{BAT}$ , the device power is switched from  $V_{CC}$  to  $V_{BAT}$  when  $V_{CC}$  drops below  $V_{BAT}$ . The registers are maintained from the  $V_{BAT}$  source until  $V_{CC}$  is returned to nominal levels (Table 1). After  $V_{CC}$  returns above  $V_{PF}$  read and write access is allowed after  $t_{REC}$  (see the “Power-Up/Down Timing” diagram).

**Table 1. Power Control**

Supply Condition	Read/Write Access	Powered By
$V_{CC} < V_{PF}$ $V_{CC} < V_{BAT}$	No	$V_{BAT}$
$V_{CC} < V_{PF}$ $V_{CC} > V_{BAT}$	No	$V_{CC}$
$V_{CC} > V_{PF}$ $V_{CC} < V_{BAT}$	Yes	$V_{CC}$
$V_{CC} > V_{PF}$ $V_{CC} > V_{BAT}$	Yes	$V_{CC}$

## Power-up/down Timing

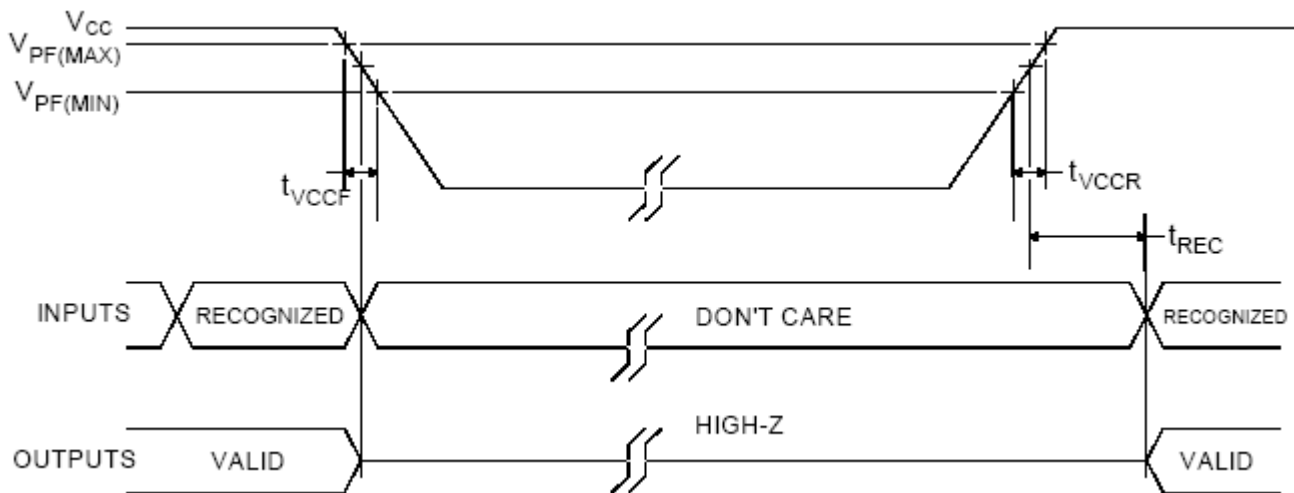

**Table 2. Power-up/down Characteristics**

Ambient Temperature -40 to +85°C

Parameter	Symbol	Conditions	Min.	Typ.	Max.	Units
Recovery at Power-up	$t_{REC}$	(see note below)			2	ms
$V_{CC}$ Fall Time; $V_{PF(MAX)}$ to $V_{PF(MIN)}$	$t_{VCCF}$		300			$\mu$ s
$V_{CC}$ Rise Time; $V_{PF(MIN)}$ to $V_{PF(MAX)}$	$t_{VCCR}$		0			$\mu$ s

**Note:** This delay applies only if the oscillator is running. If the oscillator is disabled or stopped, no power-up delay occurs.

## RTC and RAM Address Map

The address map for the RTC and RAM registers shown in Table 3. The RTC registers and control register are located in address locations 00H to 07H. The RAM registers are located in address locations 08H to 3FH. During a multibyte access, when the register pointer reaches 3FH (the end of RAM space) it wraps around to location 00H (the beginning of the clock space). On an I<sup>2</sup>C START, STOP, or register pointer incrementing to location 00H, the current time and date is transferred to a second set of registers. The time and date in the secondary registers are read in a multibyte data transfer, while the clock continues to run. This eliminates the need to re-read the registers in case of an update of the main registers during a read.

**Table 3. RTC and RAM Address Map**

Address	Bit 7	Bit 6	Bit 5	Bit 4	Bit 3	Bit 2	Bit 1	Bit 0	Function	Range
00H	CH	10 seconds			Seconds				Seconds	00 - 59
01H	0	10 minutes			Minutes				Minutes	00 - 59
02H	0	12/24	AM/PM	10 hour	Hour				Hours	1 - 12 + AM/PM 00 - 23
			10 hour							
03H	0	0	0	0	0	Day			Day	1 - 7
04H	0	0	10 date		Date				Date	01 - 31
05H	0	0	0	10 month	Month				Month	01 - 12
06H	10 year				Year				Year	00 - 99
07H	OUT	0	OSF	SQWE	0	0	RS1	RS0	Control	
08H - 3FH									RAM 56 x 8	00H - FFH

**Note:** Bits listed as "0" should always be written and read as 0.

## Clock and Calendar

Table 3 shows the address map of the RTC registers. The time and date information is obtained by reading the appropriate register bytes. The time and calendar are set or initialized by writing the appropriate register bytes. The contents of the time and calendar registers are in the BCD format. Bit 7 of Register 0 is the clock halt (CH) bit. When this bit is set to 1, the oscillator is disabled. When cleared to 0, the oscillator is enabled. The clock can be halted whenever the timekeeping functions are not required, which decreases  $V_{BAT}$  current.

The day-of-week register increments at midnight. Values that correspond to the day of week are user-defined but must be sequential (i.e., if 1 equals Sunday, then 2 equals Monday, and so on). Illogical time and date entries result in undefined operation.

When reading or writing the time and date registers, secondary (user) buffers are used to prevent errors when the internal registers update. When reading the time and

date registers, the user buffers are synchronized to the internal registers on any start or stop, and when the address pointer rolls over to zero. The countdown chain is reset whenever the seconds register is written. Write transfers occurs on the acknowledge pulse from the device. To avoid rollover issues, once the countdown chain is reset, the remaining time and date registers must be written within one second. If enabled, the 1 Hz square-wave output transitions high 500 ms after the seconds data transfer, provided the oscillator is already running.

**Note that the initial power-on state of all registers, unless otherwise specified, is not defined. Therefore, it is important to enable the oscillator (CH = 0) during initial configuration.**

The IDT1338B-31 runs in either 12-hour or 24-hour mode. Bit 6 of the hours register is defined as the 12-hour or 24-hour mode-select bit. When high, the 12-hour mode is selected. In the 12-hour mode, bit 5 is the AM/PM bit, with

logic high being PM. In the 24-hour mode, bit 5 is the second 10-hour bit (20–23 hours). If the 12/24-hour mode select is changed, the hours register must be re-initialized to the new format.

update of the main registers during a read.

On an I<sup>2</sup>C START, the current time is transferred to a second set of registers. The time information is read from these secondary registers, while the clock continues to run. This eliminates the need to re-read the registers in case of an

## Table 4. Control Register (07H)

The control register controls the operation of the SQW/OUT pin and provides oscillator status.

Bit #	Bit 7	Bit 6	Bit 5	Bit 4	Bit 3	Bit 2	Bit 1	Bit 0
Name	OUT	0	OSF	SQWE	0	0	RS1	RS0
POR	1	0	1	1	0	0	1	1

**Bit 7: Output Control (OUT).** Controls the output level of the SQW/OUT pin when the square-wave output is disabled. If SQWE = 0, the logic level on the SQW/OUT pin is 1 if OUT = 1; it is 0 if OUT = 0.

**Bit 5: Oscillator Stop Flag (OSF).** A logic 1 in this bit indicates that the oscillator has stopped or was stopped for some time period and can be used to judge the validity of the clock and calendar data. This bit is edge triggered, and is set to logic 1 when the internal circuitry senses the oscillator has transitioned from a normal run state to a STOP condition. The following are examples of conditions that may cause the OSF bit to be set:

- 1) The first time power is applied.
- 2) The voltage present on VCC and VBAT are insufficient to support oscillation.
- 3) The CH bit is set to 1, disabling the oscillator.
- 4) External influences on the crystal (i.e., noise, leakage, etc.).

This bit remains at logic 1 until written to logic 0. This bit can only be written to logic 0. Attempting to write OSF to logic 1 leaves the value unchanged.

**Bit 4: Square-Wave Enable (SQWE).** When set to logic 1, this bit enables the oscillator output to operate with either VCC or V<sub>BAT</sub> applied. The frequency of the square-wave output depends upon the value of the RS0 and RS1 bits.

**Bits 1 and 0: Rate Select (RS1 and RS0).** These bits control the frequency of the square-wave output when the square-wave output has been enabled. The table below lists the square-wave frequencies that can be selected with the RS bits.

## Table 5. Square Wave Output

OUT	RS1	RS0	SQW Output	SQWE
X	0	0	1 Hz	1
X	0	1	4.096 kHz	1
X	1	0	8.192 kHz	1
X	1	1	32.768 kHz	1
0	X	X	0	0
1	X	X	1	0

## I<sup>2</sup>C Serial Data Bus

The IDT1338B-31 supports the I<sup>2</sup>C bus protocol. A device that sends data onto the bus is defined as a transmitter and a device receiving data as a receiver. The device that controls the message is called a master. The devices that are controlled by the master are referred to as slaves. The bus must be controlled by a master device that generates the serial clock (SCL), controls the bus access, and generates the START and STOP conditions. The IDT1338B-31 operates as a slave on the I<sup>2</sup>C bus. Within the bus specifications, a standard mode (100 kHz maximum clock rate) and a fast mode (400 kHz maximum clock rate) are defined. The IDT1338B-31 works in both modes. Connections to the bus are made via the open-drain I/O lines SDA and SCL.

The following bus protocol has been defined (see the “Data Transfer on I<sup>2</sup>C Serial Bus” figure):

- Data transfer may be initiated only when the bus is not busy.
- During data transfer, the data line must remain stable whenever the clock line is HIGH. Changes in the data line while the clock line is HIGH are interpreted as control signals.

Accordingly, the following bus conditions have been defined:

**Bus not busy:** Both data and clock lines remain HIGH.

**Start data transfer:** A change in the state of the data line, from HIGH to LOW, while the clock is HIGH, defines a START condition.

**Stop data transfer:** A change in the state of the data line, from LOW to HIGH, while the clock line is HIGH, defines the STOP condition.

**Data valid:** The state of the data line represents valid data when, after a START condition, the data line is stable for the duration of the HIGH period of the clock signal. The data on the line must be changed during the LOW period of the clock signal. There is one clock pulse per bit of data.

Each data transfer is initiated with a START condition and terminated with a STOP condition. The number of data bytes transferred between START and STOP conditions is not limited, and is determined by the master device. The information is transferred byte-wise and each receiver

acknowledges with a ninth bit.

**Acknowledge:** Each receiving device, when addressed, is obliged to generate an acknowledge after the reception of each byte. The master device must generate an extra clock pulse that is associated with this acknowledge bit.

A device that acknowledges must pull down the SDA line during the acknowledge clock pulse in such a way that the SDA line is stable LOW during the HIGH period of the acknowledge related clock pulse. Of course, setup and hold times must be taken into account. A master must signal an end of data to the slave by not generating an acknowledge bit on the last byte that has been clocked out of the slave. In this case, the slave must leave the data line HIGH to enable the master to generate the STOP condition.



## Data Transfer on I<sup>2</sup>C Serial Bus



Depending upon the state of the  $\overline{R/W}$  bit, two types of data transfer are possible:

1) **Data transfer from a master transmitter to a slave receiver.** The first byte transmitted by the master is the slave address. Next follows a number of data bytes. The slave returns an acknowledge bit after each received byte. Data is transferred with the most significant bit (MSB) first.

2) **Data transfer from a slave transmitter to a master receiver.** The first byte (the slave address) is transmitted by the master. The slave then returns an acknowledge bit. This is followed by the slave transmitting a number of data bytes. The master returns an acknowledge bit after all received bytes other than the last byte. At the end of the last received byte, a “not acknowledge” is returned. The master device generates all of the serial clock pulses and the START and STOP conditions. A transfer is ended with a STOP condition or with a repeated START condition. Since a repeated START condition is also the beginning of the next serial transfer, the bus is not released. Data is transferred with the most significant bit (MSB) first.

The IDT1338B-31 can operate in the following two modes:

1) **Slave Receiver Mode (Write Mode):** Serial data and clock are received through SDA and SCL. After each byte is received an acknowledge bit is transmitted. START and STOP conditions are recognized as the beginning and end of a serial transfer. Address recognition is performed by hardware after reception of the slave address and direction

bit (see the “Data Write–Slave Receiver Mode” figure). The slave address byte is the first byte received after the START condition is generated by the master. The slave address byte contains the 7-bit IDT1338B-31 address, which is 1101000, followed by the direction bit ( $\overline{R/W}$ ), which is 0 for a write. After receiving and decoding the slave address byte the slave outputs an acknowledge on the SDA line. After the IDT1338B-31 acknowledges the slave address + write bit, the master transmits a register address to the IDT1338B-31. This sets the register pointer on the IDT1338B-31, with the IDT1338B-31 acknowledging the transfer. The master may then transmit zero or more bytes of data, with the IDT1338B-31 acknowledging each byte received. The address pointer increments after each data byte is transferred. The master generates a STOP condition to terminate the data write.

2) **Slave Transmitter Mode (Read Mode):** The first byte is received and handled as in the slave receiver mode. However, in this mode, the direction bit indicates that the transfer direction is reversed. Serial data is transmitted on SDA by the IDT1338B-31 while the serial clock is input on SCL. START and STOP conditions are recognized as the beginning and end of a serial transfer (see the “Data Read–Slave Transmitter Mode” figure). The slave address byte is the first byte received after the START condition is generated by the master. The slave address byte contains the 7-bit IDT1338B-31 address, which is 1101000, followed by the direction bit ( $\overline{R/W}$ ), which is 1 for a read. After receiving and decoding the slave address byte the slave outputs an acknowledge on the SDA line. The IDT1338B-31

then begins to transmit data starting with the register address pointed to by the register pointer. If the register pointer is not written to before the initiation of a read mode the first address that is read is the last one stored in the register pointer. The address pointer is incremented after each byte is transferred. The IDT1338B-31 must receive a “not acknowledge” to end a read.

**Data Write – Slave Receiver Mode**

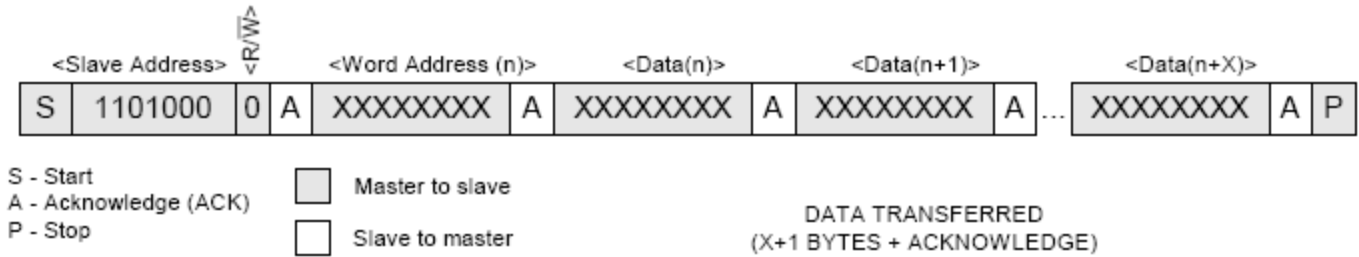

**Data Read (from current Pointer location) – Slave Transmitter Mode**

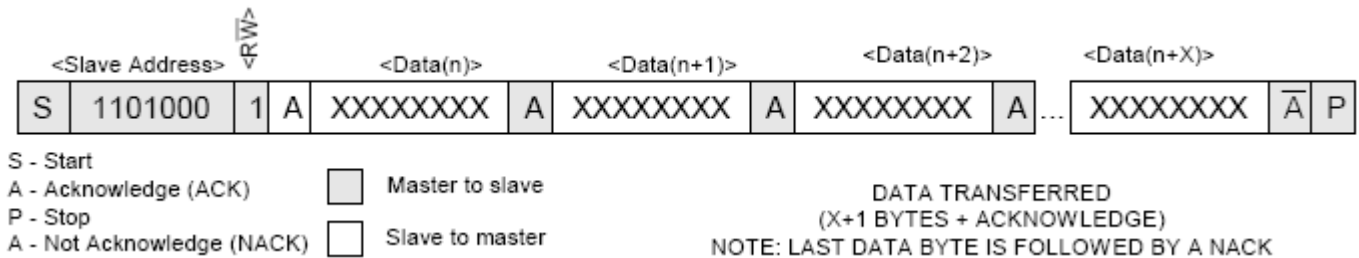

**Data Read (Write Pointer, then Read) – Slave Receive and Transmit**

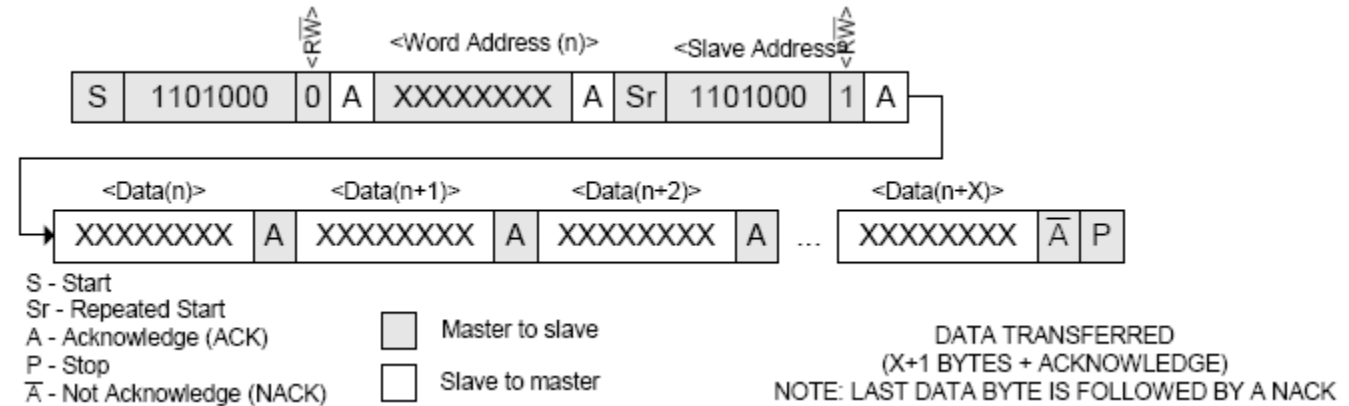

## Handling, PCB Layout, and Assembly

The IDT1338B-31 package contains a quartz tuning-fork crystal. Pick-and-place equipment may be used, but precautions should be taken to ensure that excessive shocks are avoided. Ultrasonic cleaning equipment should be avoided to prevent damage to the crystal.

Avoid running signal traces under the package, unless a ground plane is placed between the package and the signal line. All NC (no connect) pins must be connected to ground.

Moisture-sensitive packages are shipped from the factory dry-packed. Handling instructions listed on the package label must be followed to prevent damage during reflow. Refer to the IPC/JEDEC J-STD-020 standard for moisture-sensitive device (MSD) classifications.

## Absolute Maximum Ratings

Stresses above the ratings listed below can cause permanent damage to the IDT1338B-31. These ratings, which are standard values for IDT commercially rated parts, are stress ratings only. Functional operation of the device at these or any other conditions above those indicated in the operational sections of the specifications is not implied. Exposure to absolute maximum rating conditions for extended periods can affect product reliability. Electrical parameters are guaranteed only over the recommended operating temperature range.

Item	Rating
Voltage Range on Any Pin Relative to Ground	-0.3 V to +6.0 V
Storage Temperature	-55 to +125° C
Soldering Temperature	260° C

## Recommended DC Operating Conditions

( $V_{CC} = V_{CC(MIN)}$  to  $V_{CC(MAX)}$ ,  $T_A = -40^{\circ}\text{C}$  to  $+85^{\circ}\text{C}$ , unless otherwise noted. Typical values are at  $V_{CC} = 3.3\text{ V}$ ,  $T_A = +25^{\circ}\text{C}$ , unless otherwise noted.) (Note 1)

Parameter	Symbol	Min.	Typ.	Max.	Units
Ambient Operating Temperature	$T_A$	-40		+85	°C
$V_{BAT}$ Input Voltage, Note 2	$V_{BAT}$	1.3	3.0	3.7	
Pull-up Resistor Voltage (SQW/OUT), Note 2	$V_{PU}$			5.5	V
Logic 1, Note 2	$V_{IH}$	$0.7V_{CC}$		$V_{CC} + 0.3$	V
Logic 0, Note 2	$V_{IL}$	-0.3		$+0.3V_{CC}$	V
<b>Supply Voltage</b>					
IDT1338-18	$V_{CC}$	$V_{PF}$	1.8	5.5	V
IDT1338-31		$V_{PF}$	3.3	5.5	
<b>Power Fail Voltage</b>					
IDT1338-18	$V_{PF}$	1.40	1.62	1.71	V
IDT1338-31		2.45	2.7	2.97	

## DC Electrical Characteristics

( $V_{CC} = V_{CC(MIN)}$  to  $V_{CC(MAX)}$ ,  $T_A = -40^{\circ}\text{C}$  to  $+85^{\circ}\text{C}$ , unless otherwise noted. Typical values are at  $V_{CC} = 3.3\text{ V}$ ,  $T_A = +25^{\circ}\text{C}$ , unless otherwise noted.) (Note 1)

Parameter	Symbol	Conditions	Min.	Typ.	Max.	Units
Input Leakage	$I_{LI}$	Note 3			1	$\mu\text{A}$
I/O Leakage	$I_{LO}$	Note 4			1	$\mu\text{A}$
SDA Logic 0 Output	$I_{OLSDA}$	$V_{CC} > 2\text{ V}$ ; $V_{OL} = 0.4\text{ V}$			3.0	$\text{mA}$
		$V_{CC} < 2\text{ V}$ ; $V_{OL} = 0.2V_{CC}$			3.0	
SQW/OUT Logic 0 Output	$I_{OLSQW}$	$V_{CC} > 2\text{ V}$ ; $V_{OL} = 0.4\text{ V}$			3.0	$\text{mA}$
		$1.71\text{ V} < V_{CC} < 2\text{ V}$ ; $V_{OL} = 0.2V_{CC}$			3.0	$\text{mA}$
		$1.3\text{ V} < V_{CC} < 1.71\text{ V}$ ; $V_{OL} = 0.2V_{CC}$			250	$\mu\text{A}$
Active Supply Current (Note 5)	$I_{CCA}$	IDT1338-18		75	150	$\mu\text{A}$
		IDT1338-31; $V_{CC} \leq 3.63\text{ V}$		120	200	
		IDT1338-31; $3.63\text{ V} < V_{CC} \leq 5.5\text{ V}$			325	
Standby Current (Note 6)	$I_{CCS}$	IDT1338-18		60	100	$\mu\text{A}$
		IDT1338-31; $V_{CC} \leq 3.63\text{ V}$		85	125	
		IDT1338-31; $3.63\text{ V} < V_{CC} \leq 5.5\text{ V}$			200	
$V_{BAT}$ Leakage Current ( $V_{CC}$ Active)	$I_{BATLKG}$			25	100	$\text{nA}$

## DC Electrical Characteristics

( $V_{CC} = 0\text{ V}$ ,  $T_A = -40^{\circ}\text{C}$  to  $+85^{\circ}\text{C}$ , unless otherwise noted. Typical values are at  $V_{BAT} = 3.0\text{ V}$ ,  $T_A = +25^{\circ}\text{C}$ , unless otherwise noted.) (Note 1)

Parameter	Symbol	Conditions	Min.	Typ.	Max.	Units
$V_{BAT}$ Current (OSC ON); $V_{BAT} = 3.7\text{ V}$ , SQW/OUT OFF	$I_{BATOSC1}$	Note 7		800	1200	$\text{nA}$
$V_{BAT}$ Current (OSC ON); $V_{BAT} = 3.7\text{ V}$ , SQW/OUT ON	$I_{BATOSC2}$	Note 7		1025	1400	$\text{nA}$
$V_{BAT}$ Data-Retention Current (OSC OFF); $V_{BAT} = 3.7\text{ V}$	$I_{BATDAT}$	Note 7		10	100	$\text{nA}$

## AC Electrical Characteristics

( $V_{CC} = V_{CC(MIN)}$  to  $V_{CC(MAX)}$ ,  $T_A = -40^{\circ}\text{C}$  to  $+85^{\circ}\text{C}$ ) (Note 1)

Parameter	Symbol	Conditions	Min.	Typ.	Max.	Units
SCL Clock Frequency	$f_{SCL}$	Fast Mode	100		400	kHz
		Standard Mode	0		100	
Bus Free Time Between a STOP and START Condition	$t_{BUF}$	Fast Mode	1.3			$\mu\text{s}$
		Standard Mode	4.7			
Hold Time (Repeated) START Condition, Note 8	$t_{HD:STA}$	Fast Mode	0.6			$\mu\text{s}$
		Standard Mode	4.0			
Low Period of SCL Clock	$t_{LOW}$	Fast Mode	1.3			$\mu\text{s}$
		Standard Mode	4.7			
High Period of SCL Clock	$t_{HIGH}$	Fast Mode	0.6			$\mu\text{s}$
		Standard Mode	4.0			
Setup Time for a Repeated START Condition	$t_{SU:STA}$	Fast Mode	0.6			$\mu\text{s}$
		Standard Mode	4.7			
Data Hold Time (Notes 9, 10)	$t_{HD:DAT}$	Fast Mode	0		0.9	$\mu\text{s}$
		Standard Mode	0			
Data Setup Time (Note 11)	$t_{SU:DAT}$	Fast Mode	100			ns
		Standard Mode	250			
Rise Time of Both SDA and SCL Signals (Note 12)	$t_R$	Fast Mode	$20 + 0.1C_B$		300	ns
		Standard Mode	$20 + 0.1C_B$		1000	
Fall Time of Both SDA and SCL Signals (Note 12)	$t_F$	Fast Mode	$20 + 0.1C_B$		300	ns
		Standard Mode	$20 + 0.1C_B$		300	
Setup Time for STOP Condition	$t_{SU:STO}$	Fast Mode	0.6			$\mu\text{s}$
		Standard Mode	4.0			
Capacitive Load for Each Bus Line (Note 12)	$C_B$				400	pF
I/O Capacitance (SDA, SCL)	$C_{I/O}$	Note 13			10	pF
Oscillator Stop Flag (OSF) Delay	$t_{OSF}$	Note 14		100		ms

**WARNING:** Negative undershoots below 0.3 V while the device is in battery-backed mode may cause loss of data.

**Note 1:** Limits at  $-40^{\circ}\text{C}$  are guaranteed by design and are not production tested.

**Note 2:** All voltages referenced to ground.

**Note 3:** SCL only.

**Note 4:** SDA and SQW/OUT.

**Note 5:**  $I_{CCA}$ —SCL clocking at max frequency = 400 kHz.

**Note 6:** Specified with the I<sup>2</sup>C bus inactive.

**Note 7:** Measured with a 32.768 kHz crystal on X1 and X2.

**Note 8:** After this period, the first clock pulse is generated.

**Note 9:** A device must internally provide a hold time of at least 300 ns for the SDA signal (referred to the  $V_{IHMIN}$  of the SCL signal) to bridge the undefined region of the falling edge of SCL.

**Note 10:** The maximum  $t_{HD:DAT}$  need only be met if the device does not stretch the LOW period ( $t_{LOW}$ ) of the SCL signal.

**Note 11:** A fast-mode device can be used in a standard-mode system, but the requirement  $t_{SU:DAT} \geq 250$  ns must then be met. This is automatically the case if the device does not stretch the LOW period of the SCL signal. If such a device does stretch the LOW period of the SCL signal, it must output the next data bit to the SDA line  $t_{R(MAX)} + t_{SU:DAT} = 1000 + 250 = 1250$  ns before the SCL line is released.

**Note 12:**  $C_B$ —total capacitance of one bus line in pF.

**Note 13:** Guaranteed by design. Not production tested.

**Note 14:** The parameter  $t_{OSF}$  is the period of time the oscillator must be stopped for the OSF flag to be set over the voltage range of  $0.0V \leq V_{CC} \leq V_{CCMAX}$  and  $1.3V \leq V_{BACKUP} \leq 3.7V$ .

## Timing Diagram



### Typical Operating Characteristics

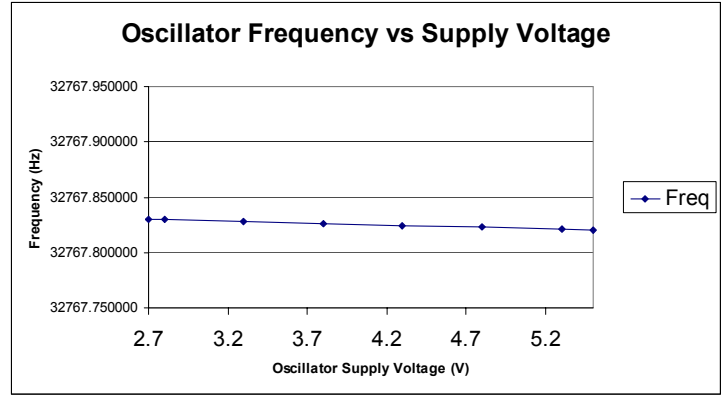
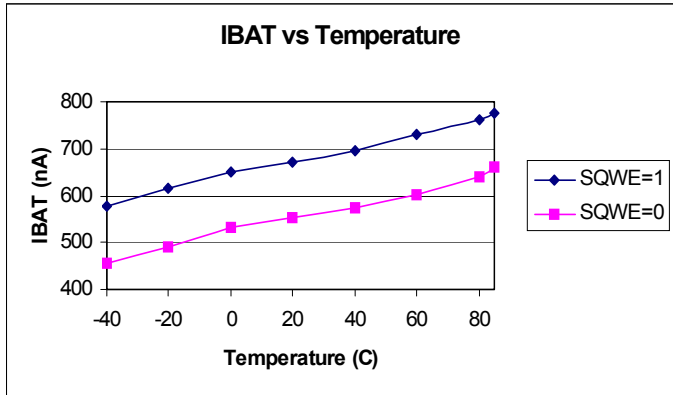
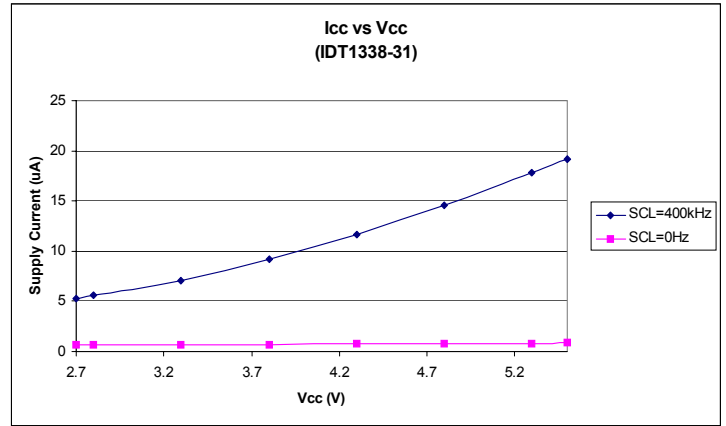
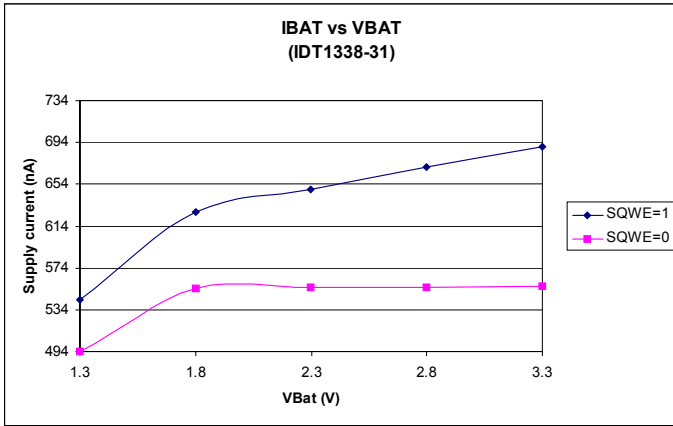

### Thermal Characteristics for 8MSOP

Parameter	Symbol	Conditions	Min.	Typ.	Max.	Units
Thermal Resistance Junction to Ambient	$\theta_{JA}$	Still air		95		°C/W
Thermal Resistance Junction to Case	$\theta_{JC}$			48		°C/W

### Thermal Characteristics for 8SOIC

Parameter	Symbol	Conditions	Min.	Typ.	Max.	Units
Thermal Resistance Junction to Ambient	$\theta_{JA}$	Still air		150		°C/W
	$\theta_{JA}$	1 m/s air flow		140		°C/W
	$\theta_{JA}$	3 m/s air flow		120		°C/W
Thermal Resistance Junction to Case	$\theta_{JC}$			40		°C/W

### Thermal Characteristics for 16SOIC

Parameter	Symbol	Conditions	Min.	Typ.	Max.	Units
Thermal Resistance Junction to Ambient	$\theta_{JA}$	Still air		120		°C/W
	$\theta_{JA}$	1 m/s air flow		115		°C/W
	$\theta_{JA}$	3 m/s air flow		105		°C/W
Thermal Resistance Junction to Case	$\theta_{JC}$			58		°C/W

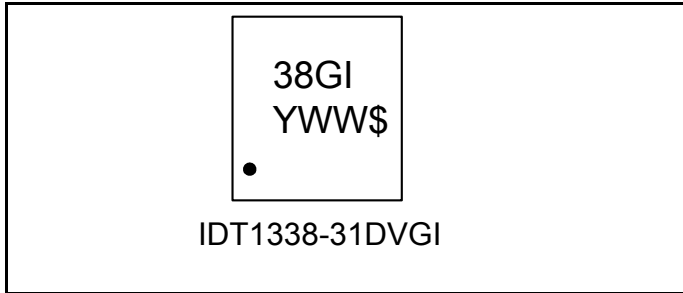
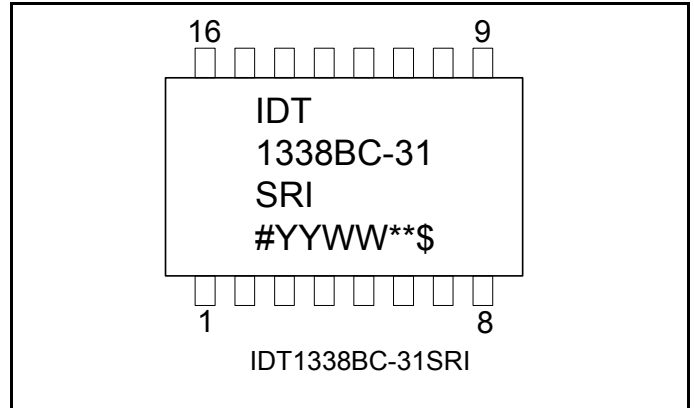
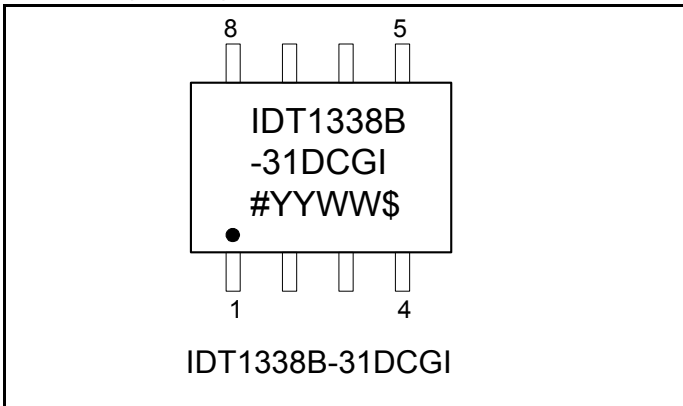

**Marking Diagram (8 MSOP)****Marking Diagram (16 SOIC)****Marking Diagram (8 SOIC)**

## Notes:

1. '#' is the lot number.
2. '\$' is the assembly mark code.
3. YYWW is the last two digits of the year and week that the part was assembled.
4. "G" denotes RoHS compliant package.
5. "I" denotes industrial grade.
6. Bottom marking: country of origin if not USA.

### Package Outline and Package Dimensions (8-pin SOIC, 150 Mil. Body)

Package dimensions are kept current with JEDEC Publication No. 95

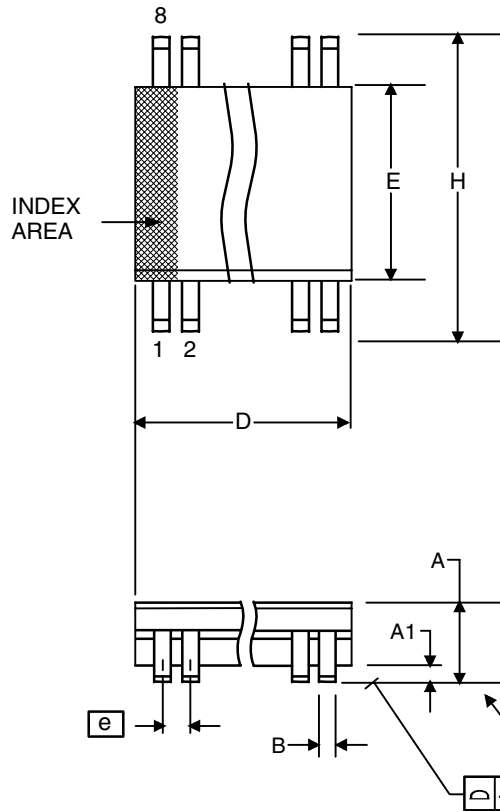

Symbol	Millimeters		Inches	
	Min	Max	Min	Max
A	1.35	1.75	.0532	.0688
A1	0.10	0.25	.0040	.0098
B	0.33	0.51	.013	.020
C	0.19	0.25	.0075	.0098
D	4.80	5.00	.1890	.1968
E	3.80	4.00	.1497	.1574
e	1.27 BASIC		0.050 BASIC	
H	5.80	6.20	.2284	.2440
h	0.25	0.50	.010	.020
L	0.40	1.27	.016	.050
$\alpha$	0°	8°	0°	8°

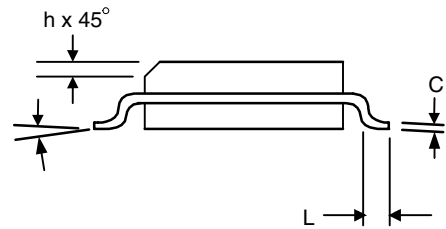

### Package Outline and Package Dimensions (8-pin MSOP, 3.00 mm Body)

Package dimensions are kept current with JEDEC Publication No. 95

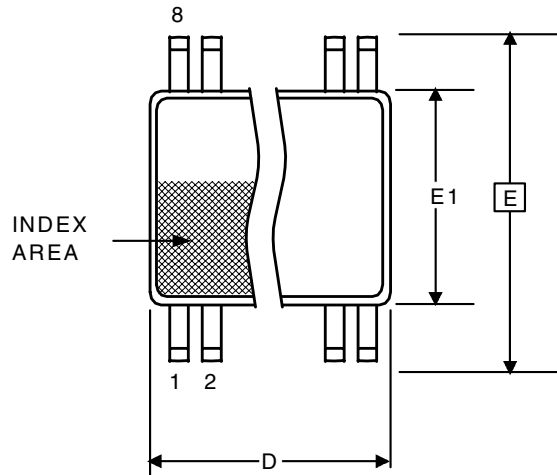

Symbol	Millimeters		Inches*	
	Min	Max	Min	Max
A	--	1.10	--	0.043
A1	0	0.15	0	0.006
A2	0.79	0.97	0.031	0.038
b	0.22	0.38	0.008	0.015
C	0.08	0.23	0.003	0.009
D	3.00 BASIC		0.118 BASIC	
E	4.90 BASIC		0.193 BASIC	
E1	3.00 BASIC		0.118 BASIC	
e	0.65 Basic		0.0256 Basic	
L	0.40	0.80	0.016	0.032
$\alpha$	0°	8°	0°	8°
aaa	-	0.10	-	0.004

\*For reference only. Controlling dimensions in mm.

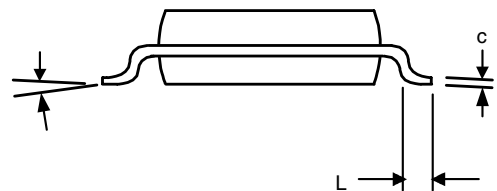
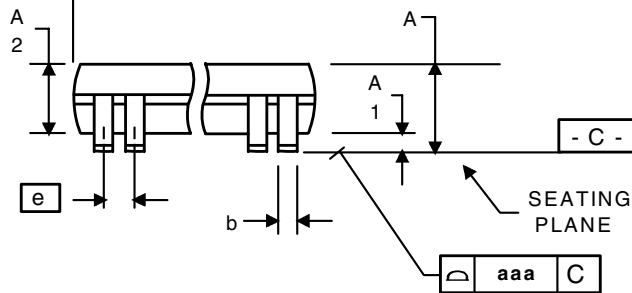

### Package Outline and Package Dimensions (16-pin SOIC, 300 mil Body)

Package dimensions are kept current with JEDEC Publication No. 95

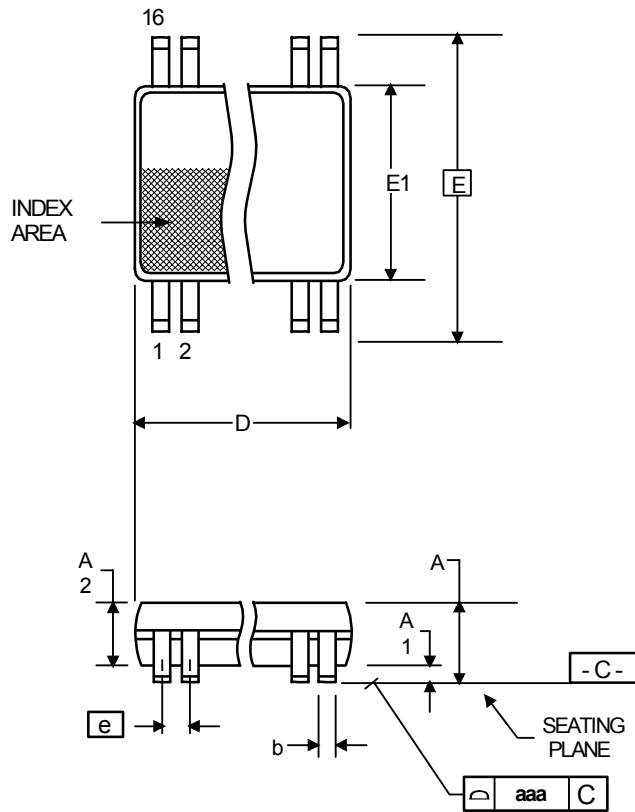

Symbol	Millimeters		Inches*	
	Min	Max	Min	Max
A	--	2.65	--	0.104
A1	0.10	--	0.0040	--
A2	2.05	2.55	0.081	0.100
b	0.33	0.51	0.013	0.020
c	0.18	0.32	0.007	0.013
D	10.10	10.50	0.397	0.413
E	10.00	10.65	0.394	0.419
E1	7.40	7.60	0.291	0.299
e	1.27 Basic		0.050 Basic	
L	0.40	1.27	0.016	0.050
α	0°	8°	0°	8°
aaa	-	0.10	-	0.004

\*For reference only. Controlling dimensions in mm.

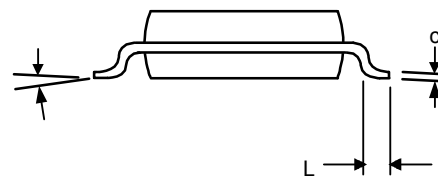

## Ordering Information

Part / Order Number	Marking	Shipping Packaging	Package	Temperature
1338B-31DVGI	see page 17	Tubes	8-pin MSOP	-40 to +85° C
1338B-31DVGI8		Tape and Reel	8-pin MSOP	-40 to +85° C
1338B-31DCGI		Tubes	8-pin SOIC	-40 to +85° C
1338B-31DCGI8		Tape and Reel	8-pin SOIC	-40 to +85° C
1338BC-31SRI		Tubes	16-pin SOIC	-40 to +85° C
1338BC-31SRI8		Tape and Reel	16-pin SOIC	-40 to +85° C

The IDT1338 packages are RoHS compliant. Packages without the integrated crystal are Pb-free; packages that include the integrated crystal (as designated with a “C” before the dash number) may include lead that is exempt under RoHS requirements. The lead finish is JESD91 category e3.

While the information presented herein has been checked for both accuracy and reliability, Integrated Device Technology (IDT) assumes no responsibility for either its use or for the infringement of any patents or other rights of third parties, which would result from its use. No other circuits, patents, or licenses are implied. This product is intended for use in normal commercial applications. Any other applications such as those requiring extended temperature range, high reliability, or other extraordinary environmental requirements are not recommended without additional processing by IDT. IDT reserves the right to change any circuitry or specifications without notice. IDT does not authorize or warrant any IDT product for use in life support devices or critical medical instruments.

## Revision History

Rev.	Originator	Date	Description of Change
A	LPL	11/23/09	New device. Initial release.



## Notice

1. Descriptions of circuits, software and other related information in this document are provided only to illustrate the operation of semiconductor products and application examples. You are fully responsible for the incorporation or any other use of the circuits, software, and information in the design of your product or system. Renesas Electronics disclaims any and all liability for any losses and damages incurred by you or third parties arising from the use of these circuits, software, or information.
2. Renesas Electronics hereby expressly disclaims any warranties against and liability for infringement or any other claims involving patents, copyrights, or other intellectual property rights of third parties, by or arising from the use of Renesas Electronics products or technical information described in this document, including but not limited to, the product data, drawings, charts, programs, algorithms, and application examples.
3. No license, express, implied or otherwise, is granted hereby under any patents, copyrights or other intellectual property rights of Renesas Electronics or others.
4. You shall not alter, modify, copy, or reverse engineer any Renesas Electronics product, whether in whole or in part. Renesas Electronics disclaims any and all liability for any losses or damages incurred by you or third parties arising from such alteration, modification, copying or reverse engineering.
5. Renesas Electronics products are classified according to the following two quality grades: "Standard" and "High Quality". The intended applications for each Renesas Electronics product depends on the product's quality grade, as indicated below.
  - "Standard": Computers; office equipment; communications equipment; test and measurement equipment; audio and visual equipment; home electronic appliances; machine tools; personal electronic equipment; industrial robots; etc.
  - "High Quality": Transportation equipment (automobiles, trains, ships, etc.); traffic control (traffic lights); large-scale communication equipment; key financial terminal systems; safety control equipment; etc.Unless expressly designated as a high reliability product or a product for harsh environments in a Renesas Electronics data sheet or other Renesas Electronics document, Renesas Electronics products are not intended or authorized for use in products or systems that may pose a direct threat to human life or bodily injury (artificial life support devices or systems; surgical implantations; etc.), or may cause serious property damage (space system; undersea repeaters; nuclear power control systems; aircraft control systems; key plant systems; military equipment; etc.). Renesas Electronics disclaims any and all liability for any damages or losses incurred by you or any third parties arising from the use of any Renesas Electronics product that is inconsistent with any Renesas Electronics data sheet, user's manual or other Renesas Electronics document.
6. When using Renesas Electronics products, refer to the latest product information (data sheets, user's manuals, application notes, "General Notes for Handling and Using Semiconductor Devices" in the reliability handbook, etc.), and ensure that usage conditions are within the ranges specified by Renesas Electronics with respect to maximum ratings, operating power supply voltage range, heat dissipation characteristics, installation, etc. Renesas Electronics disclaims any and all liability for any malfunctions, failure or accident arising out of the use of Renesas Electronics products outside of such specified ranges.
7. Although Renesas Electronics endeavors to improve the quality and reliability of Renesas Electronics products, semiconductor products have specific characteristics, such as the occurrence of failure at a certain rate and malfunctions under certain use conditions. Unless designated as a high reliability product or a product for harsh environments in a Renesas Electronics data sheet or other Renesas Electronics document, Renesas Electronics products are not subject to radiation resistance design. You are responsible for implementing safety measures to guard against the possibility of bodily injury, injury or damage caused by fire, and/or danger to the public in the event of a failure or malfunction of Renesas Electronics products, such as safety design for hardware and software, including but not limited to redundancy, fire control and malfunction prevention, appropriate treatment for aging degradation or any other appropriate measures. Because the evaluation of microcomputer software alone is very difficult and impractical, you are responsible for evaluating the safety of the final products or systems manufactured by you.
8. Please contact a Renesas Electronics sales office for details as to environmental matters such as the environmental compatibility of each Renesas Electronics product. You are responsible for carefully and sufficiently investigating applicable laws and regulations that regulate the inclusion or use of controlled substances, including without limitation, the EU RoHS Directive, and using Renesas Electronics products in compliance with all these applicable laws and regulations. Renesas Electronics disclaims any and all liability for damages or losses occurring as a result of your noncompliance with applicable laws and regulations.
9. Renesas Electronics products and technologies shall not be used for or incorporated into any products or systems whose manufacture, use, or sale is prohibited under any applicable domestic or foreign laws or regulations. You shall comply with any applicable export control laws and regulations promulgated and administered by the governments of any countries asserting jurisdiction over the parties or transactions.
10. It is the responsibility of the buyer or distributor of Renesas Electronics products, or any other party who distributes, disposes of, or otherwise sells or transfers the product to a third party, to notify such third party in advance of the contents and conditions set forth in this document.
11. This document shall not be reprinted, reproduced or duplicated in any form, in whole or in part, without prior written consent of Renesas Electronics.
12. Please contact a Renesas Electronics sales office if you have any questions regarding the information contained in this document or Renesas Electronics products.

(Note1) "Renesas Electronics" as used in this document means Renesas Electronics Corporation and also includes its directly or indirectly controlled subsidiaries.

(Note2) "Renesas Electronics product(s)" means any product developed or manufactured by or for Renesas Electronics.

(Rev.4.0-1 November 2017)

## Corporate Headquarters

TOYOSU FORESIA, 3-2-24 Toyosu,  
Koto-ku, Tokyo 135-0061, Japan  
[www.renesas.com](http://www.renesas.com)

## Contact Information

For further information on a product, technology, the most up-to-date version of a document, or your nearest sales office, please visit:  
[www.renesas.com/contact/](http://www.renesas.com/contact/)

## Trademarks

Renesas and the Renesas logo are trademarks of Renesas Electronics Corporation. All trademarks and registered trademarks are the property of their respective owners.