

### Features:

- ◆ True Dual-Port memory cells which allow simultaneous access of the same memory location
- ◆ High-speed data access
  - Commercial: 4.2ns (133MHz)(max.)
  - Industrial: 4.2ns (133MHz)(max.)
- ◆ Selectable Pipelined or Flow-Through output mode
- ◆ Counter enable and repeat features
- ◆ Interrupt Flags
- ◆ Full synchronous operation on both ports
  - 7.5ns cycle time, 133MHz operation (9.5Gbps bandwidth)
  - 1.5ns setup to clock and 0.5ns hold on all control, data, and address inputs @ 133MHz
  - Fast 4.2ns clock to data out

- Data input, address, byte enable and control registers
- Self-timed write allows fast cycle time
- ◆ Separate byte controls for multiplexed bus and bus matching compatibility
- ◆ Dual Cycle Deselect (DCD) for Pipelined Output Mode
- ◆ 2.5V (±100mV) power supply for core
- ◆ LVTTTL compatible, selectable 3.3V (±150mV) or 2.5V (±100mV) power supply for I/Os and control signals on each port
- ◆ Includes JTAG functionality
- ◆ Available in a 256-pin Ball Grid Array (BGA)
- ◆ Common BGA footprint provides design flexibility over seven density generations (512K to 36M-bit)
- ◆ Green parts available, see ordering information

### Functional Block Diagram

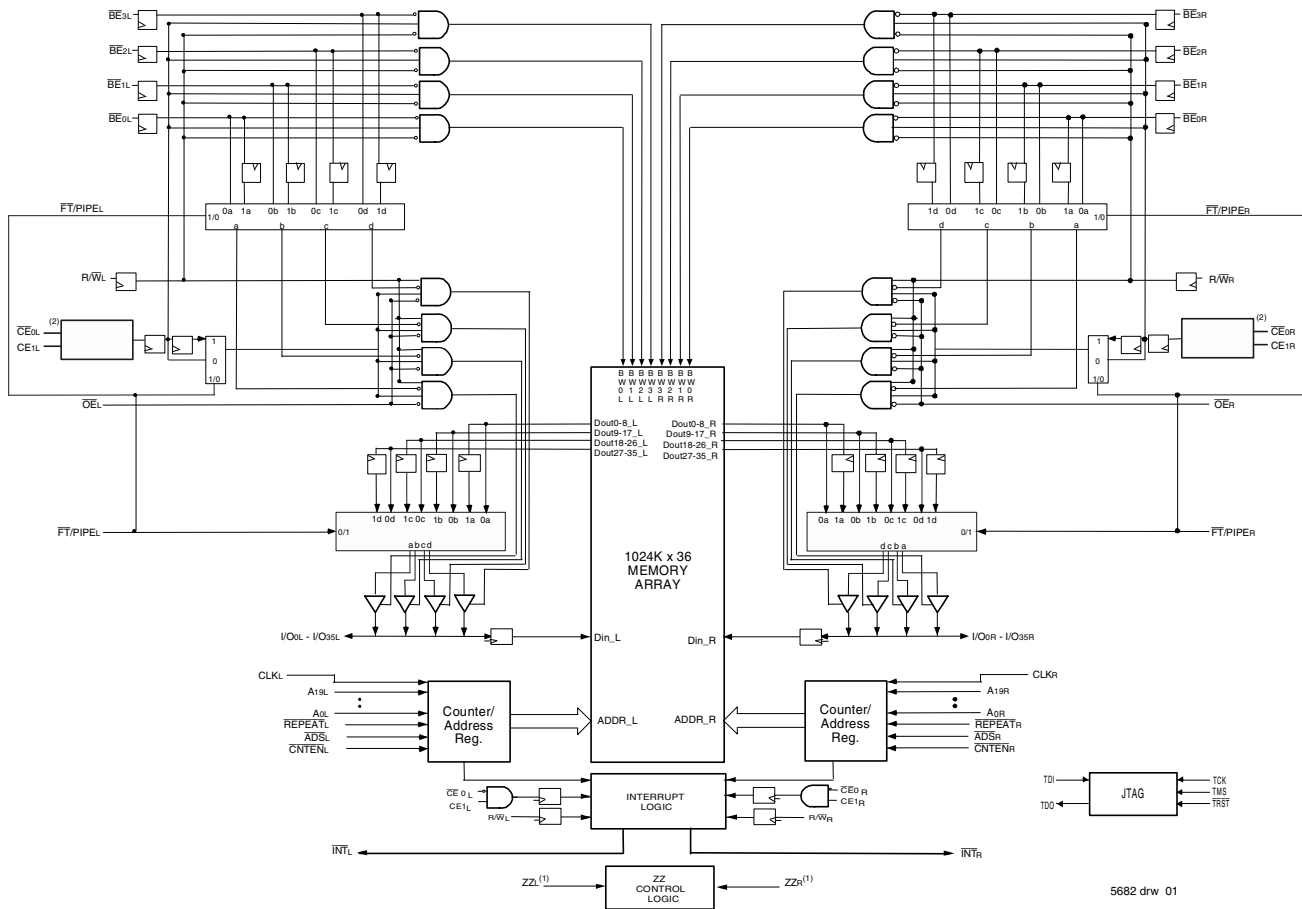

### NOTES:

1. The sleep mode pin shuts off all dynamic inputs, except JTAG inputs, when asserted. All static inputs, i.e., PL/FTx and OPTx and the sleep mode pins themselves (ZZx) are not affected during sleep mode.
2. See Truth Table I for Functionality.

## Description:

The IDT70T3509M is a high-speed 1024K x 36 bit synchronous Dual-Port RAM. The memory array utilizes Dual-Port memory cells to allow simultaneous access of any address from both ports. Registers on control, data, and address inputs provide minimal setup and hold times. The timing latitude provided by this approach allows systems to be designed with very short cycle times. With an input data register, the IDT70T3509M has been optimized for applications having unidirectional

or bidirectional data flow in bursts. An automatic power down feature, controlled by  $\overline{CE}_0$  and  $CE_1$ , permits the on-chip circuitry of each port to enter a very low standby power mode.

The 70T3509M can support an operating voltage of either 3.3V or 2.5V on one or both ports, controllable by the OPT pins. The power supply for the core of the device ( $V_{DD}$ ) is at 2.5V.

Pin Configuration (1,2,3,4)

70T3509M  
BP256<sup>(5,7)</sup>  
BPG256<sup>(5,7)</sup>

256-Pin BGA  
Top View<sup>(6)</sup>

08/03/04

A1 NC	A2 TDI	A3 A19L	A4 A17L	A5 A14L	A6 A11L	A7 A8L	A8 $\overline{BE}_{2L}$	A9 CE1L	A10 $\overline{OE}_{L}$	A11 $\overline{CNTEN}_{L}$	A12 A5L	A13 A2L	A14 A0L	A15 NC	A16 NC
B1 I/O18L	B2 NC	B3 TDO	B4 A18L	B5 A15L	B6 A12L	B7 A9L	B8 $\overline{BE}_{3L}$	B9 $\overline{CE}_{0L}$	B10 R/WL	B11 REPEATL	B12 A4L	B13 A1L	B14 VDD	B15 I/O17L	B16 NC
C1 I/O18R	C2 I/O19L	C3 VSS	C4 A16L	C5 A13L	C6 A10L	C7 A7L	C8 $\overline{BE}_{1L}$	C9 $\overline{BE}_{0L}$	C10 CLKL	C11 $\overline{ADSL}$	C12 A6L	C13 A3L	C14 OPTL	C15 I/O17R	C16 I/O16L
D1 I/O20R	D2 I/O19R	D3 I/O20L	D4 PIPE/FTL	D5 VDDQL	D6 VDDQL	D7 VDDQR	D8 VDDQR	D9 VDDQL	D10 VDDQL	D11 VDDQR	D12 VDDQR	D13 VDD	D14 I/O15R	D15 I/O15L	D16 I/O16R
E1 I/O21R	E2 I/O21L	E3 I/O22L	E4 VDDQL	E5 VDD	E6 VDD	E7 $\overline{INT}_{L}$	E8 VSS	E9 VSS	E10 VSS	E11 VDD	E12 VDD	E13 VDDQR	E14 I/O13L	E15 I/O14L	E16 I/O14R
F1 I/O23L	F2 I/O22R	F3 I/O23R	F4 VDDQL	F5 VDD	F6 NC	F7 NC	F8 VSS	F9 VSS	F10 VSS	F11 VSS	F12 VDD	F13 VDDQR	F14 I/O12R	F15 I/O13R	F16 I/O12L
G1 I/O24R	G2 I/O24L	G3 I/O25L	G4 VDDQR	G5 VSS	G6 VSS	G7 VSS	G8 VSS	G9 VSS	G10 VSS	G11 VSS	G12 VSS	G13 VDDQL	G14 I/O10L	G15 I/O11L	G16 I/O11R
H1 I/O26L	H2 I/O25R	H3 I/O26R	H4 VDDQR	H5 VSS	H6 VSS	H7 VSS	H8 VSS	H9 VSS	H10 VSS	H11 VSS	H12 VSS	H13 VDDQL	H14 I/O9R	H15 I/O9L	H16 I/O10R
J1 I/O27L	J2 I/O28R	J3 I/O27R	J4 VDDQL	J5 ZZR	J6 VSS	J7 VSS	J8 VSS	J9 VSS	J10 VSS	J11 VSS	J12 ZZL	J13 VDDQR	J14 I/O8R	J15 I/O7R	J16 I/O8L
K1 I/O29R	K2 I/O29L	K3 I/O28L	K4 VDDQL	K5 VSS	K6 VSS	K7 VSS	K8 VSS	K9 VSS	K10 VSS	K11 VSS	K12 VSS	K13 VDDQR	K14 I/O6R	K15 I/O6L	K16 I/O7L
L1 I/O30L	L2 I/O31R	L3 I/O30R	L4 VDDQR	L5 VDD	L6 NC	L7 NC	L8 VSS	L9 VSS	L10 VSS	L11 VSS	L12 VDD	L13 VDDQL	L14 I/O5L	L15 I/O4R	L16 I/O5R
M1 I/O32R	M2 I/O32L	M3 I/O31L	M4 VDDQR	M5 VDD	M6 VDD	M7 $\overline{INT}_{R}$	M8 VSS	M9 VSS	M10 VSS	M11 VDD	M12 VDD	M13 VDDQL	M14 I/O3R	M15 I/O3L	M16 I/O4L
N1 I/O33L	N2 I/O34R	N3 I/O33R	N4 PIPE/FTR	N5 VDDQR	N6 VDDQR	N7 VDDQL	N8 VDDQL	N9 VDDQR	N10 VDDQR	N11 VDDQL	N12 VDDQL	N13 VDD	N14 I/O2L	N15 I/O1R	N16 I/O2R
P1 I/O35R	P2 I/O34L	P3 TMS	P4 A16R	P5 A13R	P6 A10R	P7 A7R	P8 $\overline{BE}_{1R}$	P9 $\overline{BE}_{0R}$	P10 CLKR	P11 $\overline{ADSR}$	P12 A6R	P13 A3R	P14 I/O0L	P15 I/O0R	P16 I/O1L
R1 I/O35L	R2 NC	R3 $\overline{TRST}$	R4 A18R	R5 A15R	R6 A12R	R7 A9R	R8 $\overline{BE}_{3R}$	R9 $\overline{CE}_{0R}$	R10 R/WR	R11 REPEATR	R12 A4R	R13 A1R	R14 OPTR	R15 NC	R16 NC
T1 NC	T2 TCK	T3 A19R	T4 A17R	T5 A14R	T6 A11R	T7 A8R	T8 $\overline{BE}_{2R}$	T9 CE1R	T10 $\overline{OE}_{R}$	T11 $\overline{CNTEN}_{R}$	T12 A5R	T13 A2R	T14 A0R	T15 NC	T16 NC

5682 drw 02d

NOTES:

1. All VDD pins must be connected to 2.5V power supply.
2. All VDDQ pins must be connected to appropriate power supply: 3.3V if OPT pin for that port is set to VDD (2.5V), and 2.5V if OPT pin for that port is set to VSS (0V).
3. All VSS pins must be connected to ground supply.
4. Package body is approximately 17mm x 17mm x 1.76mm, with 1.0mm ball-pitch.
5. This package code is used to reference the package diagram.
6. This text does not indicate orientation of the actual part-marking.
7. BP-256 package thickness is 1.76mm nominal. This is thicker than the BC-256 package (1.40mm nominal) used for the lower density IDT dual-port products.

## Pin Names

Left Port	Right Port	Names
$\overline{CE}_{0L}$ , $CE_{1L}$	$\overline{CE}_{0R}$ , $CE_{1R}$	Chip Enables (Input) <sup>(5)</sup>
$R\overline{W}_L$	$R\overline{W}_R$	Read/Write Enable (Input)
$\overline{OE}_L$	$\overline{OE}_R$	Output Enable (Input)
$A_{0L}$ - $A_{19L}$	$A_{0R}$ - $A_{19R}$	Address (Input)
$I/O_{0L}$ - $I/O_{35L}$	$I/O_{0R}$ - $I/O_{35R}$	Data Input/Output
$CLK_L$	$CLK_R$	Clock (Input)
$PL/\overline{FT}_L$	$PL/\overline{FT}_R$	Pipeline/Flow-Through (Input)
$\overline{ADS}_L$	$\overline{ADS}_R$	Address Strobe Enable (Input)
$CNTEN_L$	$CNTEN_R$	Counter Enable (Input)
$REPEAT_L$	$REPEAT_R$	Counter Repeat <sup>(3)</sup> (Input)
$\overline{BE}_{0L}$ - $\overline{BE}_{3L}$	$\overline{BE}_{0R}$ - $\overline{BE}_{3R}$	Byte Enables (9-bit bytes) (Input) <sup>(5)</sup>
$V_{DD0L}$	$V_{DD0R}$	Power (I/O Bus) (3.3V or 2.5V) <sup>(1)</sup> (Input)
$OPT_L$	$OPT_R$	Option for selecting $V_{DD0x}$ <sup>(1,2)</sup> (Input)
$ZZ_L$	$ZZ_R$	Sleep Mode pin <sup>(4)</sup> (Input)
$V_{DD}$		Power (2.5V) <sup>(1)</sup> (Input)
$V_{SS}$		Ground (0V) (Input)
$TDI$		Test Data Input
$TDO$		Test Data Output
$TCK$		Test Logic Clock (10MHz) (Input)
$TMS$		Test Mode Select (Input)
$\overline{TRST}$		Reset (Initialize TAP Controller) (Input)
$\overline{INT}_L$	$\overline{INT}_R$	Interrupt Flag (Output)

5682 tbl 01

### NOTES:

- $V_{DD}$ ,  $OPT_x$ , and  $V_{DD0x}$  must be set to appropriate operating levels prior to applying inputs on the I/Os and controls for that port.
- $OPT_x$  selects the operating voltage levels for the I/Os and controls on that port. If  $OPT_x$  is set to  $V_{DD}$  (2.5V), then that port's I/Os and controls will operate at 3.3V levels and  $V_{DD0x}$  must be supplied at 3.3V. If  $OPT_x$  is set to  $V_{SS}$  (0V), then that port's I/Os and address controls will operate at 2.5V levels and  $V_{DD0x}$  must be supplied at 2.5V. The  $OPT$  pins are independent of one another—both ports can operate at 3.3V levels, both can operate at 2.5V levels, or either can operate at 3.3V with the other at 2.5V.
- When  $REPEAT_x$  is asserted, the counter will reset to the last valid address loaded via  $\overline{ADS}_x$ .
- The sleep mode pin shuts off all dynamic inputs, except JTAG inputs, when asserted. All static inputs, i.e.,  $PL/\overline{FT}_x$  and  $OPT_x$  and the sleep mode pins themselves ( $ZZ_x$ ) are not affected during sleep mode. It is recommended that boundary scan not be operated during sleep mode.
- Chip Enables and Byte Enables are double buffered when  $PL/\overline{FT} = V_{IH}$ , i.e., the signals take two cycles to deselect.

Truth Table I—Read/Write and Enable Control (1,2,3,4)

$\overline{OE}$	CLK	$\overline{CE}_0$	CE <sub>1</sub>	$\overline{BE}_3$	$\overline{BE}_2$	$\overline{BE}_1$	$\overline{BE}_0$	R/W	ZZ	Byte 3 I/O <sub>27-35</sub>	Byte 2 I/O <sub>18-26</sub>	Byte 1 I/O <sub>9-17</sub>	Byte 0 I/O <sub>0-8</sub>	MODE
X	↑	H	L	X	X	X	X	X	L	High-Z	High-Z	High-Z	High-Z	Deselected—Power Down
X	↑	L	L	X	X	X	X	X	X	Active	Active	Active	Active	Not Allowed
X	↑	H	H	X	X	X	X	X	X	Active	Active	Active	Active	Not Allowed
X	↑	L	H	H	H	H	H	X	L	High-Z	High-Z	High-Z	High-Z	All Bytes Deselected
X	↑	L	H	H	H	H	L	L	L	High-Z	High-Z	High-Z	D <sub>IN</sub>	Write to Byte 0 Only
X	↑	L	H	H	H	L	H	L	L	High-Z	High-Z	D <sub>IN</sub>	High-Z	Write to Byte 1 Only
X	↑	L	H	H	L	H	H	L	L	High-Z	D <sub>IN</sub>	High-Z	High-Z	Write to Byte 2 Only
X	↑	L	H	L	H	H	H	L	L	D <sub>IN</sub>	High-Z	High-Z	High-Z	Write to Byte 3 Only
X	↑	L	H	H	H	L	L	L	L	High-Z	High-Z	D <sub>IN</sub>	D <sub>IN</sub>	Write to Lower 2 Bytes Only
X	↑	L	H	L	L	H	H	L	L	D <sub>IN</sub>	D <sub>IN</sub>	High-Z	High-Z	Write to Upper 2 bytes Only
X	↑	L	H	L	L	L	L	L	L	D <sub>IN</sub>	D <sub>IN</sub>	D <sub>IN</sub>	D <sub>IN</sub>	Write to All Bytes
L	↑	L	H	H	H	H	L	H	L	High-Z	High-Z	High-Z	D <sub>OUT</sub>	Read Byte 0 Only
L	↑	L	H	H	H	L	H	H	L	High-Z	High-Z	D <sub>OUT</sub>	High-Z	Read Byte 1 Only
L	↑	L	H	H	L	H	H	H	L	High-Z	D <sub>OUT</sub>	High-Z	High-Z	Read Byte 2 Only
L	↑	L	H	L	H	H	H	H	L	D <sub>OUT</sub>	High-Z	High-Z	High-Z	Read Byte 3 Only
L	↑	L	H	H	H	L	L	H	L	High-Z	High-Z	D <sub>OUT</sub>	D <sub>OUT</sub>	Read Lower 2 Bytes Only
L	↑	L	H	L	L	H	H	H	L	D <sub>OUT</sub>	D <sub>OUT</sub>	High-Z	High-Z	Read Upper 2 Bytes Only
L	↑	L	H	L	L	L	L	H	L	D <sub>OUT</sub>	D <sub>OUT</sub>	D <sub>OUT</sub>	D <sub>OUT</sub>	Read All Bytes
H	↑	X	X	X	X	X	X	X	L	High-Z	High-Z	High-Z	High-Z	Outputs Disabled
X	X	X	X	X	X	X	X	X	H	High-Z	High-Z	High-Z	High-Z	Sleep Mode

5682 tbl 02

NOTES:

- "H" = V<sub>IH</sub>, "L" = V<sub>IL</sub>, "X" = Don't Care.
- $\overline{ADS}$ ,  $\overline{CNTEN}$ ,  $\overline{REPEAT}$  = X.
- $\overline{OE}$  and ZZ are asynchronous input signals.
- It is possible to read or write any combination of bytes during a given access. A few representative samples have been illustrated here.

Truth Table II—Address Counter Control (1,2)

Address	Previous Internal Address	Internal Address Used	CLK	$\overline{ADS}$	$\overline{CNTEN}$	$\overline{REPEAT}^{(6)}$	I/O <sup>(3)</sup>	MODE
An	X	An	↑	L <sup>(4)</sup>	X	H	D <sub>IO</sub> (n)	External Address Used
X	An	An + 1	↑	H	L <sup>(5)</sup>	H	D <sub>IO</sub> (n+1)	Counter Enabled—Internal Address generation <sup>(7)</sup>
X	An + 1	An + 1	↑	H	H	H	D <sub>IO</sub> (n+1)	External Address Blocked—Counter disabled (An + 1 reused)
X	X	An	↑	X	X	L <sup>(4)</sup>	D <sub>IO</sub> (n)	Counter Set to last valid $\overline{ADS}$ load

5682 tbl 03

NOTES:

- "H" = V<sub>IH</sub>, "L" = V<sub>IL</sub>, "X" = Don't Care.
- Read and write operations are controlled by the appropriate setting of R/W,  $\overline{CE}_0$ , CE<sub>1</sub>,  $\overline{BE}_n$  and  $\overline{OE}$ .
- Outputs configured in flow-through output mode: if outputs are in pipelined mode the data out will be delayed by one cycle.
- $\overline{ADS}$  and  $\overline{REPEAT}$  are independent of all other memory control signals including  $\overline{CE}_0$ , CE<sub>1</sub> and  $\overline{BE}_n$ .
- The address counter advances if  $\overline{CNTEN}$  = V<sub>IL</sub> on the rising edge of CLK, regardless of all other memory control signals including  $\overline{CE}_0$ , CE<sub>1</sub>,  $\overline{BE}_n$ .
- When  $\overline{REPEAT}$  is asserted, the counter will reset to the last valid address loaded via  $\overline{ADS}$ . This value is not set at power-up: a known location should be loaded via  $\overline{ADS}$  during initialization if desired. Any subsequent  $\overline{ADS}$  access during operations will update the  $\overline{REPEAT}$  address location.
- Address A<sub>19</sub> must be managed as part of a full depth counter implementation using the IDT70T3509M. For physical addresses 00000H through 7FFFFH the value of a A<sub>19</sub> is 0, while for physical addresses 80000H through FFFFFH the value of A<sub>19</sub> is 1. The user needs to keep track of the device counter and make sure that A<sub>19</sub> is actively driven from 0-to-1 or 1-to-0 and held as needed at the appropriate address boundaries for full depth counter operation and that A<sub>19</sub> is in the appropriate state when using the  $\overline{REPEAT}$  function.

## Recommended Operating Temperature and Supply Voltage <sup>(1)</sup>

Grade	Ambient Temperature	GND	V <sub>DD</sub>
Commercial	0°C to +70°C	0V	2.5V ± 100mV
Industrial	-40°C to +85°C	0V	2.5V ± 100mV

5682 tbl 04
**NOTES:**

1. This is the parameter TA. This is the "instant on" case temperature.

## Recommended DC Operating Conditions with V<sub>DDQ</sub> at 2.5V

Symbol	Parameter	Min.	Typ.	Max.	Unit
V <sub>DD</sub>	Core Supply Voltage	2.4	2.5	2.6	V
V <sub>DDQ</sub>	I/O Supply Voltage <sup>(3)</sup>	2.4	2.5	2.6	V
V <sub>SS</sub>	Ground	0	0	0	V
V <sub>IH</sub>	Input High Voltage (Address, Control & Data I/O Inputs) <sup>(3)</sup>	1.7	—	V <sub>DDQ</sub> + 100mV <sup>(2)</sup>	V
V <sub>IH</sub>	Input High Voltage - JTAG	1.7	—	V <sub>DD</sub> + 100mV <sup>(2)</sup>	V
V <sub>IH</sub>	Input High Voltage - ZZ, OPT, PIPE/FT	V <sub>DD</sub> - 0.2V	—	V <sub>DD</sub> + 100mV <sup>(2)</sup>	V
V <sub>IL</sub>	Input Low Voltage	-0.3 <sup>(1)</sup>	—	0.7	V
V <sub>IL</sub>	Input Low Voltage - ZZ, OPT, PIPE/FT	-0.3 <sup>(1)</sup>	—	0.2	V

5682 tbl 05a
**NOTES:**

1. V<sub>IL</sub> (min.) = -1.0V for pulse width less than tcyc/2 or 5ns, whichever is less.
2. V<sub>IH</sub> (max.) = V<sub>DDQ</sub> + 1.0V for pulse width less than tcyc/2 or 5ns, whichever is less.
3. To select operation at 2.5V levels on the I/Os and controls of a given port, the OPT pin for that port must be set to V<sub>SS</sub>(0V), and V<sub>DDQ</sub> for that port must be supplied as indicated above.

## Recommended DC Operating Conditions with V<sub>DDQ</sub> at 3.3V

Symbol	Parameter	Min.	Typ.	Max.	Unit
V <sub>DD</sub>	Core Supply Voltage	2.4	2.5	2.6	V
V <sub>DDQ</sub>	I/O Supply Voltage <sup>(3)</sup>	3.15	3.3	3.45	V
V <sub>SS</sub>	Ground	0	0	0	V
V <sub>IH</sub>	Input High Voltage (Address, Control & Data I/O Inputs) <sup>(3)</sup>	2.0	—	V <sub>DDQ</sub> + 150mV <sup>(2)</sup>	V
V <sub>IH</sub>	Input High Voltage - JTAG	1.7	—	V <sub>DD</sub> + 100mV <sup>(2)</sup>	V
V <sub>IH</sub>	Input High Voltage - ZZ, OPT, PIPE/FT	V <sub>DD</sub> - 0.2V	—	V <sub>DD</sub> + 100mV <sup>(2)</sup>	V
V <sub>IL</sub>	Input Low Voltage	-0.3 <sup>(1)</sup>	—	0.8	V
V <sub>IL</sub>	Input Low Voltage - ZZ, OPT, PIPE/FT	-0.3 <sup>(1)</sup>	—	0.2	V

5682 tbl 05b
**NOTES:**

1. V<sub>IL</sub> (min.) = -1.0V for pulse width less than tcyc/2, or 5ns, whichever is less.
2. V<sub>IH</sub> (max.) = V<sub>DDQ</sub> + 1.0V for pulse width less than tcyc/2 or 5ns, whichever is less.
3. To select operation at 3.3V levels on the I/Os and controls of a given port, the OPT pin for that port must be set to V<sub>DD</sub> (2.5V), and V<sub>DDQ</sub> for that port must be supplied as indicated above.

## Absolute Maximum Ratings <sup>(1)</sup>

Symbol	Rating	Com'l & Ind	Unit
V <sub>TERM</sub> (V <sub>DD</sub> )	V <sub>DD</sub> Terminal Voltage with Respect to GND	-0.5 to 3.6	V
V <sub>TERM</sub> <sup>(2)</sup> (V <sub>DDQ</sub> )	V <sub>DDQ</sub> Terminal Voltage with Respect to GND	-0.3 to V <sub>DDQ</sub> + 0.3	V
V <sub>TERM</sub> <sup>(2)</sup> (INPUTS and I/O's)	Input and I/O Terminal Voltage with Respect to GND	-0.3 to V <sub>DDQ</sub> + 0.3	V
T <sub>BIAS</sub> <sup>(3)</sup>	Temperature Under Bias	-55 to +125	°C
T <sub>STG</sub>	Storage Temperature	-65 to +150	°C
T <sub>JN</sub>	Junction Temperature	+150	°C
I <sub>OUT</sub> (For V <sub>DDQ</sub> = 3.3V)	DC Output Current	50	mA
I <sub>OUT</sub> (For V <sub>DDQ</sub> = 2.5V)	DC Output Current	40	mA

5682 tbl 06

### NOTES:

1. Stresses greater than those listed under ABSOLUTE MAXIMUM RATINGS may cause permanent damage to the device. This is a stress rating only and functional operation of the device at these or any other conditions above those indicated in the operational sections of this specification is not implied. Exposure to absolute maximum rating conditions for extended periods may affect reliability.
2. This is a steady-state DC parameter that applies after the power supply has reached its nominal operating value. Power sequencing is not necessary; however, the voltage on any Input or I/O pin cannot exceed V<sub>DDQ</sub> during power supply ramp up.
3. Ambient Temperature under DC Bias. No AC Conditions. Chip Deselected.

## Capacitance <sup>(1)</sup>

(T<sub>A</sub> = +25°C, F = 1.0MHz) BGA ONLY

Symbol	Parameter	Conditions	Max.	Unit
C <sub>IN</sub>	Input Capacitance	V <sub>IN</sub> = 0V	35	pF
C <sub>OUT</sub> <sup>(2)</sup>	Output Capacitance	V <sub>OUT</sub> = 0V	35	pF

5682 tbl 07

### NOTES:

1. These parameters are determined by device characterization, but are not production tested.
2. C<sub>OUT</sub> also references C<sub>IO</sub>.

## DC Electrical Characteristics Over the Operating Temperature and Supply Voltage Range (V<sub>DD</sub> = 2.5V ± 100mV)

Symbol	Parameter	Test Conditions	70T3509MS		Unit
			Min.	Max.	
I <sub>LI</sub>	Input Leakage Current <sup>(1)</sup>	V <sub>DDQ</sub> = Max., V <sub>IN</sub> = 0V to V <sub>DDQ</sub>	—	20	μA
I <sub>LI</sub>	JTAG & ZZ Input Leakage Current <sup>(1,2)</sup>	V <sub>DD</sub> = Max., V <sub>IN</sub> = 0V to V <sub>DD</sub>	—	60	μA
I <sub>LO</sub>	Output Leakage Current <sup>(1,3)</sup>	$\overline{CE}_0 = V_{IH}$ and CE <sub>1</sub> = V <sub>IL</sub> , V <sub>OUT</sub> = 0V to V <sub>DDQ</sub>	—	20	μA
V <sub>OL</sub> (3.3V)	Output Low Voltage <sup>(1)</sup>	I <sub>OL</sub> = +4mA, V <sub>DDQ</sub> = Min.	—	0.4	V
V <sub>OH</sub> (3.3V)	Output High Voltage <sup>(1)</sup>	I <sub>OH</sub> = -4mA, V <sub>DDQ</sub> = Min.	2.4	—	V
V <sub>OL</sub> (2.5V)	Output Low Voltage <sup>(1)</sup>	I <sub>OL</sub> = +2mA, V <sub>DDQ</sub> = Min.	—	0.4	V
V <sub>OH</sub> (2.5V)	Output High Voltage <sup>(1)</sup>	I <sub>OH</sub> = -2mA, V <sub>DDQ</sub> = Min.	2.0	—	V

5682 tbl 08

### NOTES:

1. V<sub>DDQ</sub> is selectable (3.3V/2.5V) via OPT pins. Refer to p.5 for details.
2. Applicable only for TMS, TDI and TRST inputs.
3. Outputs tested in tri-state mode.

DC Electrical Characteristics Over the Operating Temperature and Supply Voltage Range <sup>(3)</sup> ( $V_{DD} = 2.5V \pm 100mV$ )

Symbol	Parameter	Test Condition	Version	70T3509MS133 Com'l & Ind		Unit
				Typ. <sup>(4)</sup>	Max.	
IDD	Dynamic Operating Current (Both Ports Active)	$\overline{CE}_L$ and $\overline{CE}_R = V_{IL}$ , Outputs Disabled, $f = f_{MAX}^{(1)}$	COM'L S	800	1120	mA
			IND S	800	1370	
ISB1 <sup>(6)</sup>	Standby Current (Both Ports - TTL Level Inputs)	$\overline{CE}_L = \overline{CE}_R = V_{IH}$ $f = f_{MAX}^{(1)}$	COM'L S	560	760	mA
			IND S	560	940	
ISB2 <sup>(6)</sup>	Standby Current (One Port - TTL Level Inputs)	$\overline{CE}^*A = V_{IL}$ and $\overline{CE}^*B = V_{IH}^{(5)}$ Active Port Outputs Disabled, $f=f_{MAX}^{(1)}$	COM'L S	680	880	mA
			IND S	680	1090	
ISB3	Full Standby Current (Both Ports - CMOS Level Inputs)	Both Ports $\overline{CE}_{0L} = \overline{CE}_{0R} \geq V_{DDQ} - 0.2V$ and $CE_{1L} = CE_{1R} \leq 0.2V$ , $V_{IN} \geq V_{DDQ} - 0.2V$ or $V_{IN} \leq 0.2V$ , $f = 0^{(2)}$	COM'L S	20	60	mA
			IND S	20	80	
ISB4 <sup>(6)</sup>	Full Standby Current (One Port - CMOS Level Inputs)	$\overline{CE}^*A \leq 0.2V$ and $\overline{CE}^*B \geq V_{DDQ} - 0.2V^{(5)}$ $V_{IN} \geq V_{DDQ} - 0.2V$ or $V_{IN} \leq 0.2V$ Active Port, Outputs Disabled, $f = f_{MAX}^{(1)}$	COM'L S	680	880	mA
			IND S	680	1090	
Izz	Sleep Mode Current (Both Ports - TTL Level Inputs)	$ZZ_L = ZZ_R = V_{IH}$ $f=f_{MAX}^{(1)}$	COM'L S	20	60	mA
			IND S	20	80	

5682 tbl 09

NOTES:

- At  $f = f_{MAX}$ , address and control lines (except Output Enable) are cycling at the maximum frequency clock cycle of  $1/t_{cvc}$ , using "AC TEST CONDITIONS".
- $f = 0$  means no address, clock, or control lines change. Applies only to input at CMOS level standby.
- Port "A" may be either left or right port. Port "B" is the opposite from port "A".
- $V_{DD} = 2.5V$ ,  $T_A = 25^\circ C$  for Typ, and are not production tested.  $I_{DD} DC(f=0) = 30mA$  (Typ).
- $\overline{CE}_X = V_{IL}$  means  $\overline{CE}_{0X} = V_{IL}$  and  $CE_{1X} = V_{IH}$  (enabled)  
 $\overline{CE}_X = V_{IH}$  means  $\overline{CE}_{0X} = V_{IH}$  and  $CE_{1X} = V_{IL}$  (disabled)  
 $\overline{CE}_X \leq 0.2V$  means  $\overline{CE}_{0X} \leq 0.2V$  and  $CE_{1X} \geq V_{DDQ} - 0.2V$  (enabled - CMOS levels)  
 $\overline{CE}_X \geq V_{DDQ} - 0.2V$  means  $\overline{CE}_{0X} \geq V_{DDQ} - 0.2V$  and  $CE_{1X} \leq 0.2V$  (disabled - CMOS levels)  
 "X" represents "L" for left port or "R" for right port.
- ISB1, ISB2 and ISB4 will all reach full standby levels (ISB3) on the appropriate port(s) if  $ZZ_L$  and/or  $ZZ_R = V_{IH}$ .



AC Test Conditions (V<sub>DDQ</sub> - 3.3V/2.5V)

Input Pulse Levels (Address & Controls)	GND to 3.0V/GND to 2.4V
Input Pulse Levels (I/Os)	GND to 3.0V/GND to 2.4V
Input Rise/Fall Times	2ns
Input Timing Reference Levels	1.5V/1.25V
Output Reference Levels	1.5V/1.25V
Output Load	Figure 1

5682 tbl 10

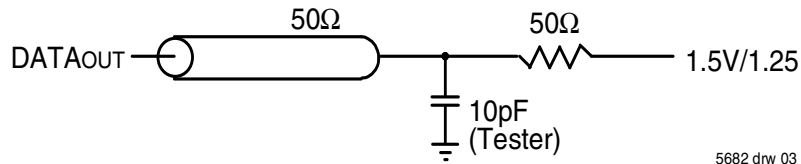

5682 drw 03

Figure 1. AC Output Test load.

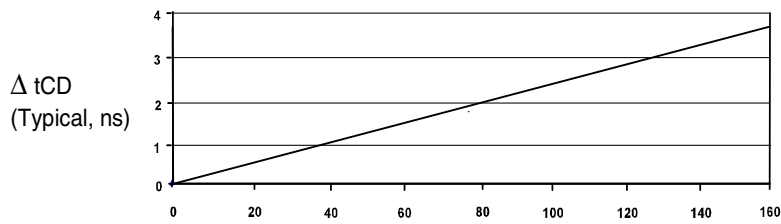

Δ Capacitance (pF) from AC Test Load

5682 drw 04

## AC Electrical Characteristics Over the Operating Temperature Range (Read and Write Cycle Timing) <sup>(2,3)</sup> ( $V_{DD} = 2.5V \pm 100mV$ , $T_A = 0^\circ C$ to $+70^\circ C$ )

		70T3509MS133 Com1 & Ind		
Symbol	Parameter	Min.	Max.	Unit
t <sub>CYC1</sub>	Clock Cycle Time (Flow-Through) <sup>(1)</sup>	25	—	ns
t <sub>CYC2</sub>	Clock Cycle Time (Pipelined) <sup>(1)</sup>	7.5	—	ns
t <sub>CH1</sub>	Clock High Time (Flow-Through) <sup>(1)</sup>	10	—	ns
t <sub>CL1</sub>	Clock Low Time (Flow-Through) <sup>(1)</sup>	10	—	ns
t <sub>CH2</sub>	Clock High Time (Pipelined) <sup>(2)</sup>	3	—	ns
t <sub>CL2</sub>	Clock Low Time (Pipelined) <sup>(1)</sup>	3	—	ns
t <sub>SA</sub>	Address Setup Time	1.8	—	ns
t <sub>HA</sub>	Address Hold Time	0.5	—	ns
t <sub>SC</sub>	Chip Enable Setup Time	1.8	—	ns
t <sub>HC</sub>	Chip Enable Hold Time	0.5	—	ns
t <sub>SB</sub>	Byte Enable Setup Time	1.8	—	ns
t <sub>HB</sub>	Byte Enable Hold Time	0.5	—	ns
t <sub>SW</sub>	R/W Setup Time	1.8	—	ns
t <sub>HW</sub>	R/W Hold Time	0.5	—	ns
t <sub>SD</sub>	Input Data Setup Time	1.8	—	ns
t <sub>HD</sub>	Input Data Hold Time	0.5	—	ns
t <sub>SAD</sub>	$\overline{ADS}$ Setup Time	1.8	—	ns
t <sub>HAD</sub>	$\overline{ADS}$ Hold Time	0.5	—	ns
t <sub>SCN</sub>	$\overline{CNTEN}$ Setup Time	1.8	—	ns
t <sub>HCN</sub>	$\overline{CNTEN}$ Hold Time	0.5	—	ns
t <sub>SRPT</sub>	$\overline{REPEAT}$ Setup Time	1.8	—	ns
t <sub>HRPT</sub>	$\overline{REPEAT}$ Hold Time	0.5	—	ns
t <sub>OE</sub>	Output Enable to Data Valid	—	4.6	ns
t <sub>OLZ</sub> <sup>(4)</sup>	Output Enable to Output Low-Z	1	—	ns
t <sub>OHZ</sub> <sup>(4)</sup>	Output Enable to Output High-Z	1	4.2	ns
t <sub>CD1</sub>	Clock to Data Valid (Flow-Through) <sup>(1)</sup>	—	15	ns
t <sub>CD2</sub>	Clock to Data Valid (Pipelined) <sup>(1)</sup>	—	4.2	ns
t <sub>DC</sub>	Data Output Hold After Clock High	1	—	ns
t <sub>CKHZ</sub> <sup>(4)</sup>	Clock High to Output High-Z	1	4.2	ns
t <sub>CKLZ</sub> <sup>(4)</sup>	Clock High to Output Low-Z	1	—	ns
t <sub>INS</sub>	Interrupt Flag Set Time	—	7	ns
t <sub>INR</sub>	Interrupt Flag Reset Time	—	7	ns
t <sub>COLS</sub>	Collision Flag Set Time	—	4.2	ns
t <sub>COLR</sub>	Collision Flag Reset Time	—	4.2	ns
t <sub>ZZSC</sub>	Sleep Mode Set Cycles	2	—	cycles
t <sub>ZZRC</sub>	Sleep Mode Recovery Cycles	3	—	cycles
<b>Port-to-Port Delay</b>				
t <sub>CO</sub>	Clock-to-Clock Offset	6	—	ns

5682 tbl 11

**NOTES:**

- The Pipelined output parameters (t<sub>CYC2</sub>, t<sub>CD2</sub>) apply to either or both left and right ports when  $\overline{FT}/PIPE_x = V_{DD}$  (2.5V). Flow-through parameters (t<sub>CYC1</sub>, t<sub>CD1</sub>) apply when  $\overline{FT}/PIPE_x = V_{SS}$  (0V) for that port.
- All input signals are synchronous with respect to the clock except for the asynchronous Output Enable ( $\overline{OE}$ ),  $\overline{FT}/PIPE$  and OPT.  $\overline{FT}/PIPE$  and OPT should be treated as DC signals, i.e. steady state during operation.
- These values are valid for either level of  $V_{DD0}$  (3.3V/2.5V). See page 6 for details on selecting the desired operating voltage levels for each port.
- Guaranteed by design (not production tested).

### Timing Waveform of Read Cycle for Pipelined Operation ( $\overline{FT}/PIPE'X' = V_{IH}$ )<sup>(1,2)</sup>

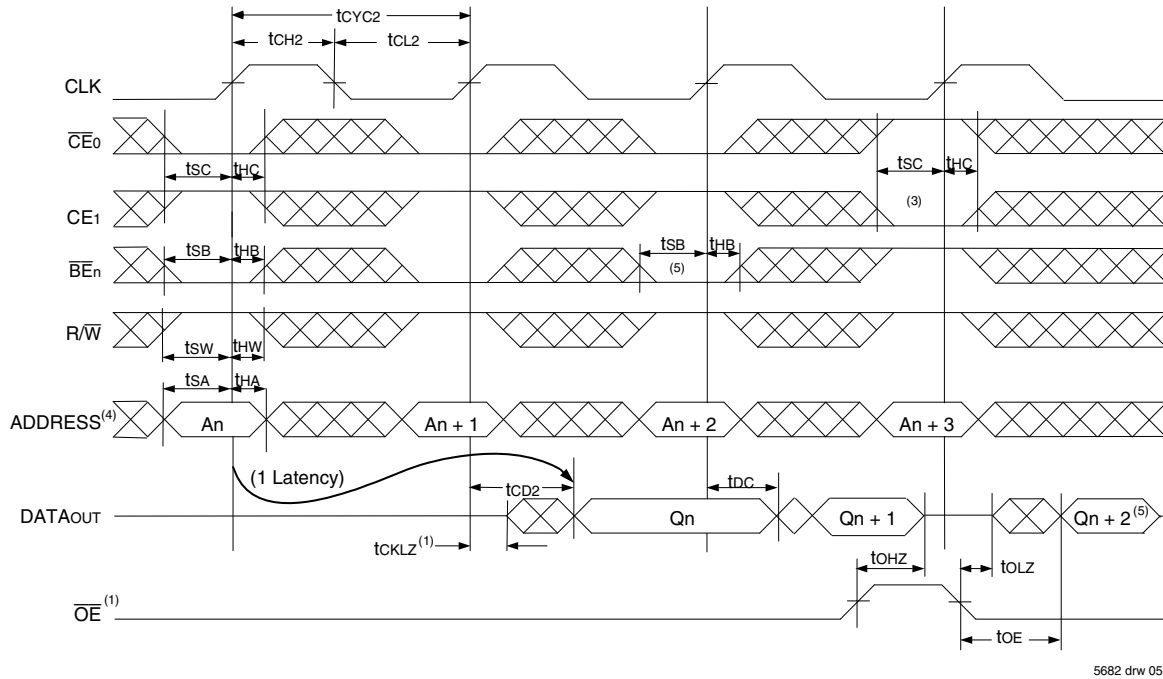

5682 drw 05

### Timing Waveform of Read Cycle for Flow-Through Output ( $\overline{FT}/PIPE'X' = V_{IL}$ )<sup>(1,2,6)</sup>

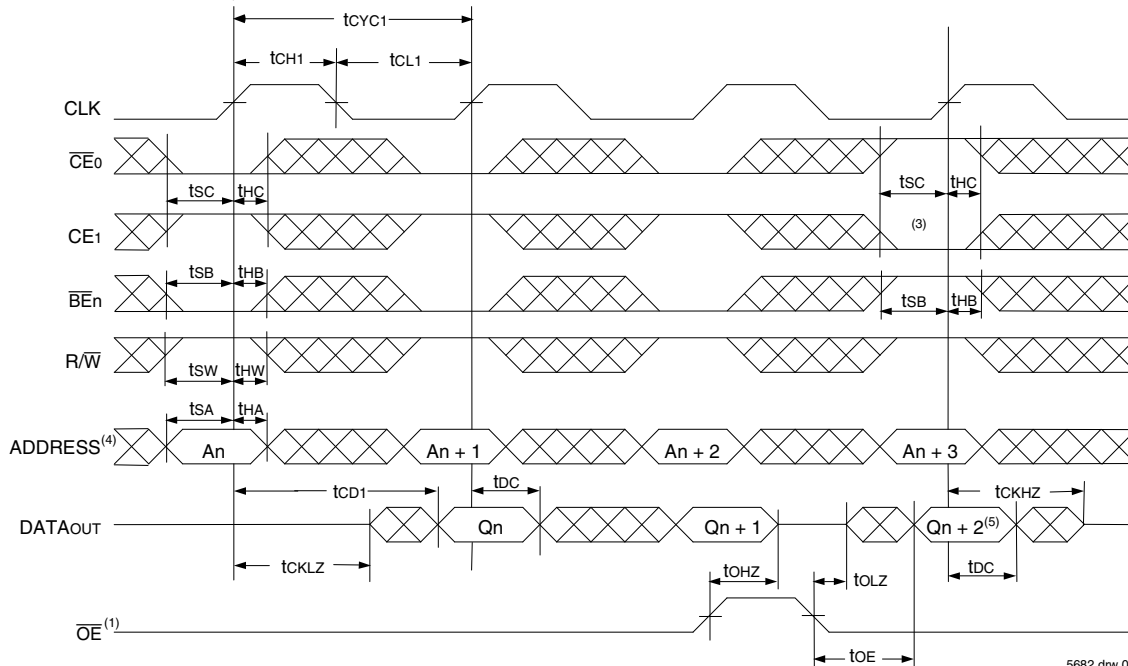

5682 drw 06

**NOTES:**

1.  $\overline{OE}$  is asynchronously controlled; all other inputs depicted in the above waveforms are synchronous to the rising clock edge.
2.  $\overline{ADS} = V_{IL}$ ,  $\overline{CNTEN}$  and  $\overline{REPEAT} = V_{IH}$ .
3. The output is disabled (High-Impedance state) by  $\overline{CE}_0 = V_{IH}$ ,  $CE_1 = V_{IL}$ ,  $\overline{BE}_n = V_{IH}$  following the next rising edge of the clock. Refer to Truth Table 1.
4. Addresses do not have to be accessed sequentially since  $\overline{ADS} = V_{IL}$  constantly loads the address on the rising edge of the CLK; numbers are for reference use only.
5. If  $\overline{BE}_n$  was HIGH, then the appropriate Byte of DATAout for  $Q_n + 2$  would be disabled (High-Impedance state).
6. "x" denotes Left or Right port. The diagram is with respect to that port.

Timing Waveform of Left Port Write to Pipelined Right Port Read<sup>(1,2,4)</sup>

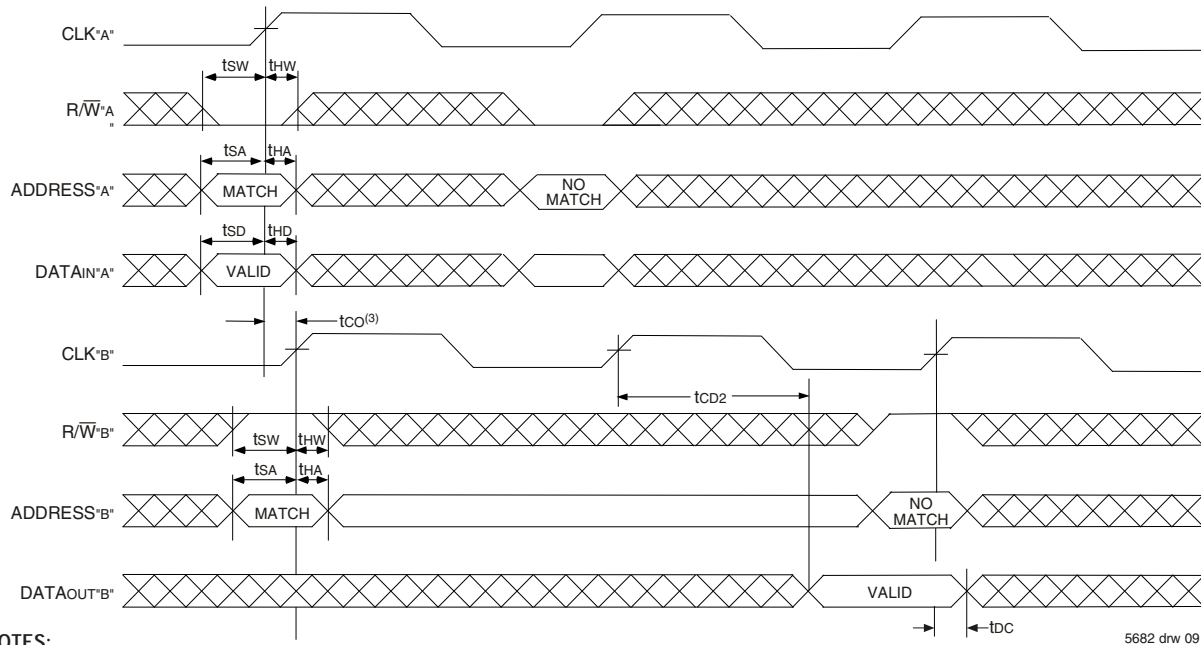

NOTES:

1.  $\overline{CE}_0$ ,  $\overline{BE}_n$ , and  $\overline{ADS} = V_{IL}$ ;  $\overline{CE}_1$ ,  $\overline{CNTEN}$ , and  $\overline{REPEAT} = V_{IH}$ .
2.  $\overline{OE} = V_{IL}$  for Port "B", which is being read from.  $\overline{OE} = V_{IH}$  for Port "A", which is being written to.
3. If  $t_{co} \leq$  minimum specified, then data from Port "B" read is not valid until following Port "B" clock cycle (ie, time from write to valid read on opposite port will be  $t_{co} + 2 t_{cyc2} + t_{cd2}$ ). If  $t_{co} >$  minimum, then data from Port "B" read is available on first Port "B" clock cycle (ie, time from write to valid read on opposite port will be  $t_{co} + t_{cyc2} + t_{cd2}$ ).
4. All timing is the same for Left and Right ports. Port "A" may be either Left or Right port. Port "B" is the opposite of Port "A"

Timing Waveform with Port-to-Port Flow-Through Read<sup>(1,2,4)</sup>

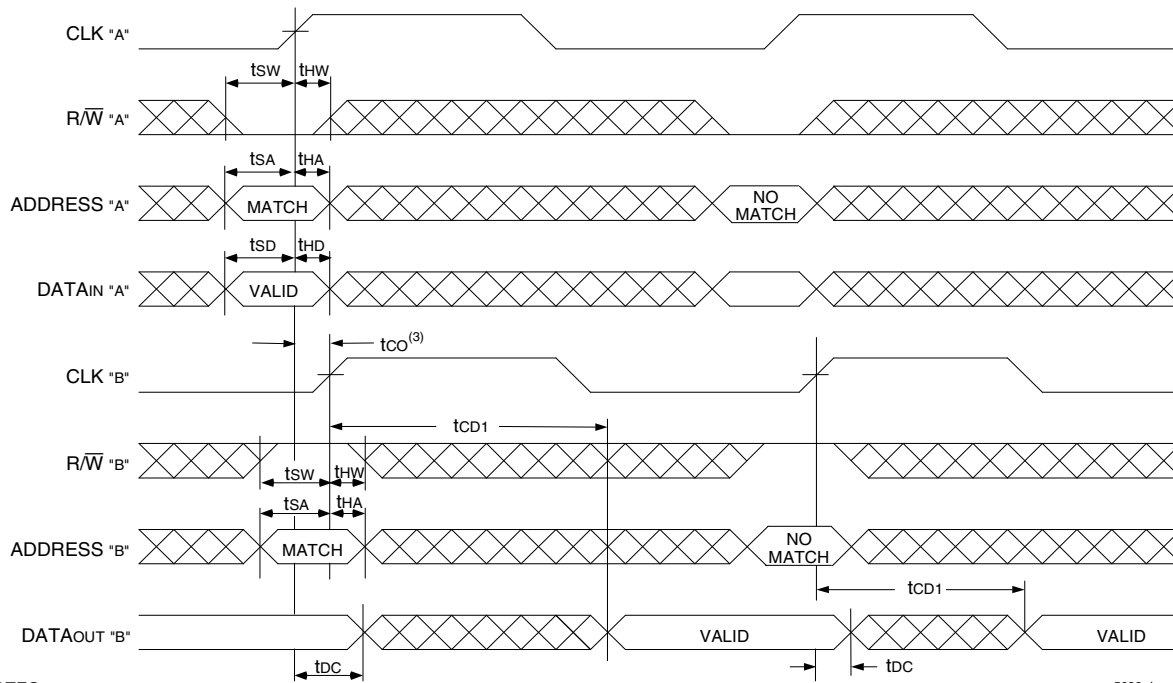

NOTES:

1.  $\overline{CE}_0$ ,  $\overline{BE}_n$ , and  $\overline{ADS} = V_{IL}$ ;  $\overline{CE}_1$ ,  $\overline{CNTEN}$ , and  $\overline{REPEAT} = V_{IH}$ .
2.  $\overline{OE} = V_{IL}$  for the Right Port, which is being read from.  $\overline{OE} = V_{IH}$  for the Left Port, which is being written to.
3. If  $t_{co} \leq$  minimum specified, then data from Port "B" read is not valid until following Port "B" clock cycle (i.e., time from write to valid read on opposite port will be  $t_{co} + t_{cyc} + t_{cd1}$ ). If  $t_{co} >$  minimum, then data from Port "B" read is available on first Port "B" clock cycle (i.e., time from write to valid read on opposite port will be  $t_{co} + t_{cd1}$ ).
4. All timing is the same for both left and right ports. Port "A" may be either left or right port. Port "B" is the opposite of Port "A".

Timing Waveform of Pipelined Read-to-Write-to-Read ( $\overline{OE} = V_{IL}$ )<sup>(2)</sup>

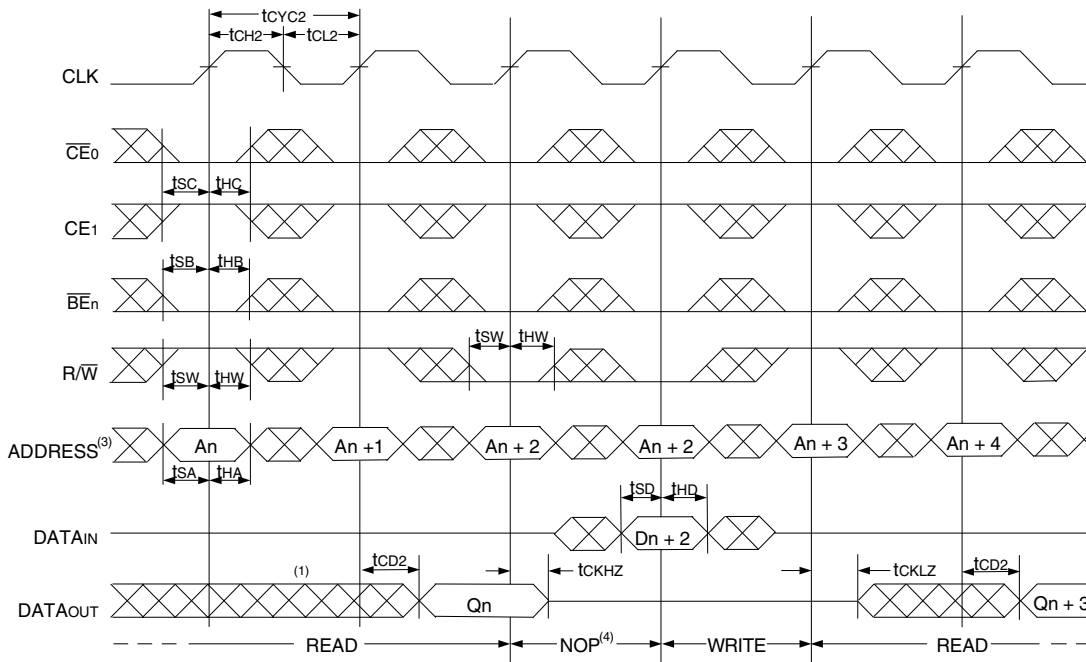

NOTES:

1. Output state (High, Low, or High-impedance) is determined by the previous cycle control signals.
2.  $\overline{CE}_0$ ,  $\overline{BE}_n$ , and  $\overline{ADS} = V_{IL}$ ;  $CE_1$ ,  $CNTEN$ , and  $\overline{REPEAT} = V_{IH}$ . "NOP" is "No Operation".
3. Addresses do not have to be accessed sequentially since  $\overline{ADS} = V_{IL}$  constantly loads the address on the rising edge of the CLK; numbers are for reference use only.
4. "NOP" is "No Operation." Data in memory at the selected address may be corrupted and should be rewritten to guarantee data integrity.

5682 drw 11

Timing Waveform of Pipelined Read-to-Write-to-Read ( $\overline{OE}$  Controlled)<sup>(2)</sup>

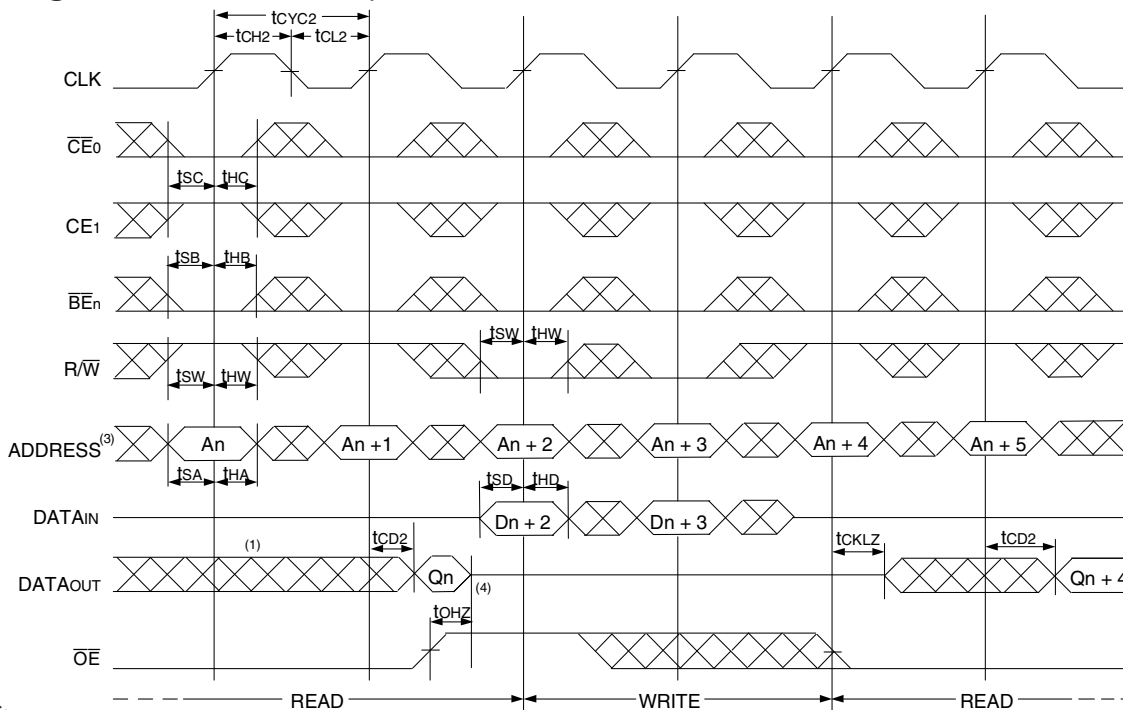

NOTES:

1. Output state (High, Low, or High-impedance) is determined by the previous cycle control signals.
2.  $\overline{CE}_0$ ,  $\overline{BE}_n$ , and  $\overline{ADS} = V_{IL}$ ;  $CE_1$ ,  $CNTEN$ , and  $\overline{REPEAT} = V_{IH}$ .
3. Addresses do not have to be accessed sequentially since  $\overline{ADS} = V_{IL}$  constantly loads the address on the rising edge of the CLK; numbers are for reference use only.
4. This timing does not meet requirements for fastest speed grade. This waveform indicates how logically it could be done if timing so allows.

5682 drw 12

Timing Waveform of Flow-Through Read-to-Write-to-Read ( $\overline{OE} = V_{IL}$ )<sup>(2)</sup>

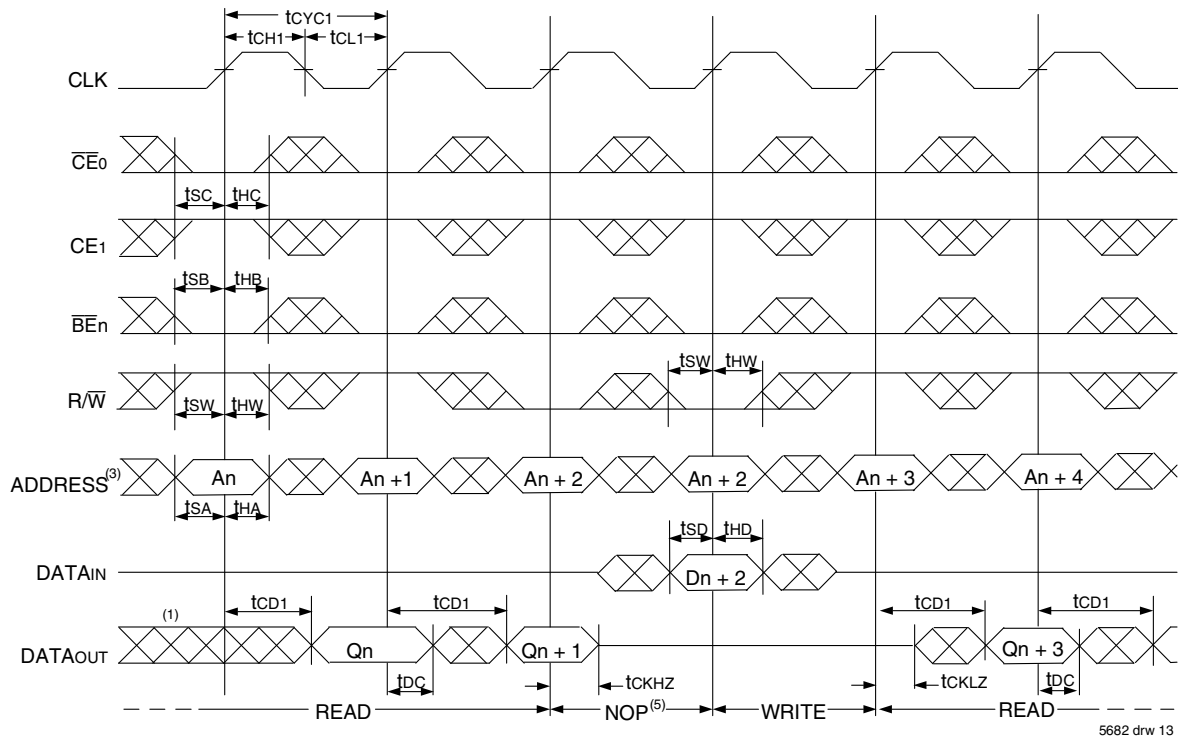

Timing Waveform of Flow-Through Read-to-Write-to-Read ( $\overline{OE}$  Controlled)<sup>(2)</sup>

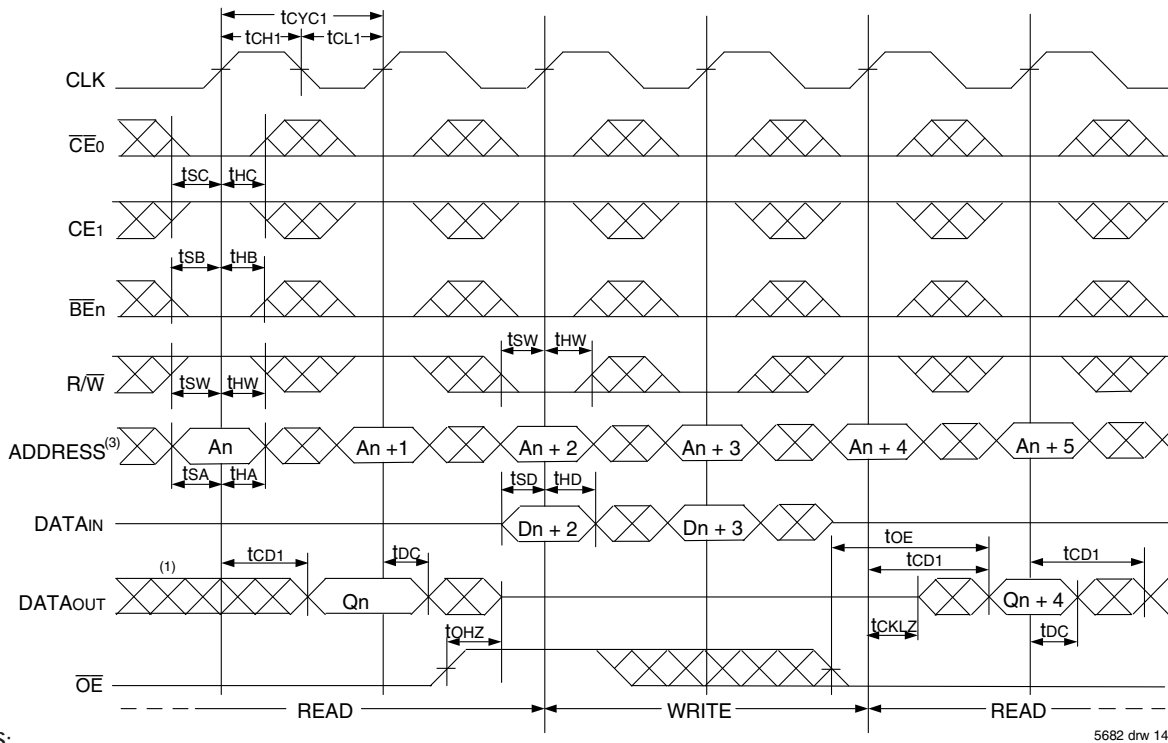

NOTES:

1. Output state (High, Low, or High-impedance) is determined by the previous cycle control signals.
2.  $\overline{CE0}$ ,  $\overline{BEn}$ , and  $\overline{ADS} = V_{IL}$ ;  $CE1$ ,  $CNTEN$ , and  $REPEAT = V_{IH}$ .
3. Addresses do not have to be accessed sequentially since  $\overline{ADS} = V_{IL}$  constantly loads the address on the rising edge of the CLK; numbers are for reference use only.
4. "NOP" is "No Operation." Data in memory at the selected address may be corrupted and should be rewritten to guarantee data integrity.

Timing Waveform of Pipelined Read with Address Counter Advance<sup>(1)</sup>

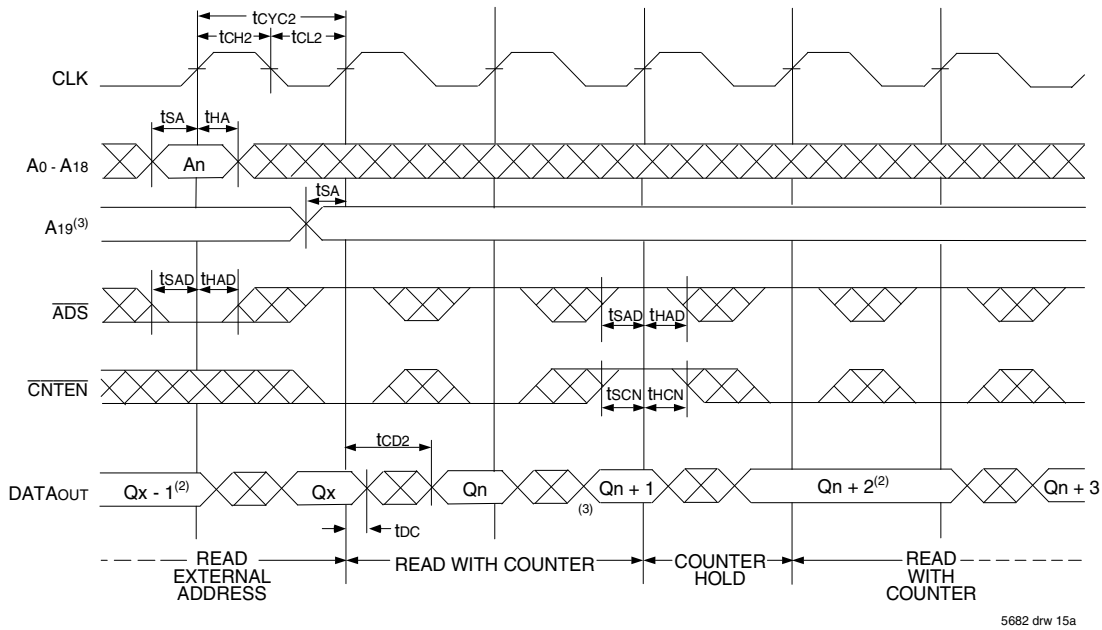

5682 drw 15a

Timing Waveform of Flow-Through Read with Address Counter Advance<sup>(1)</sup>

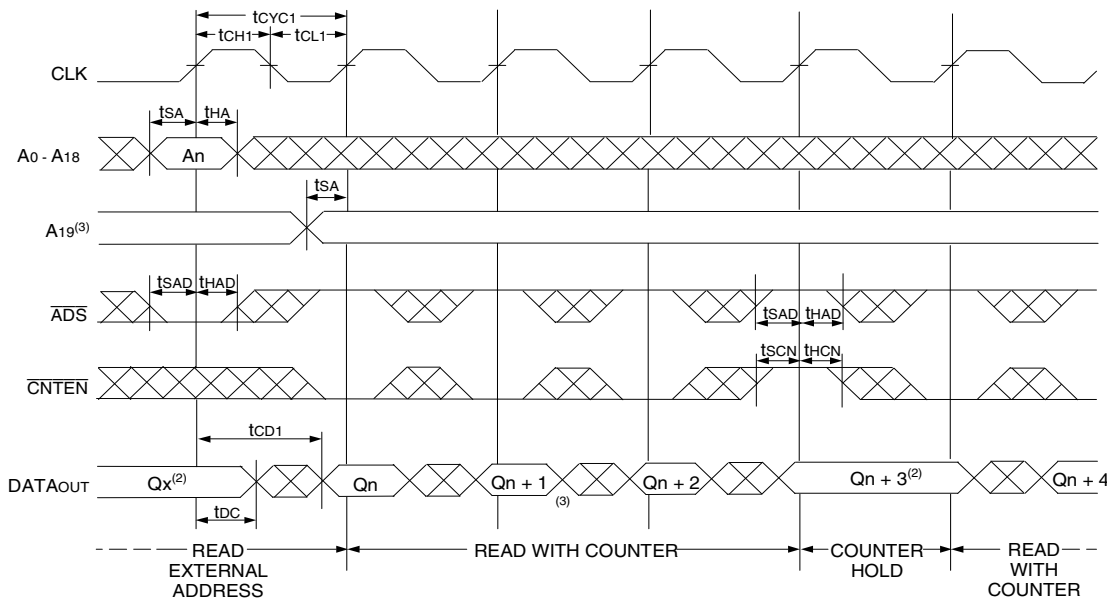

5682 drw 16a

NOTES:

1.  $\overline{CE}_0$ ,  $\overline{OE}$ ,  $\overline{BE}_n = V_{IL}$ ;  $CE_1$ ,  $R/\overline{W}$ , and  $\overline{REPEAT} = V_{IH}$ .
2. If there is no address change via  $\overline{ADS} = V_{IL}$  (loading a new address) or  $\overline{CNTEN} = V_{IL}$  (advancing the address), i.e.  $\overline{ADS} = V_{IH}$  and  $\overline{CNTEN} = V_{IH}$ , then the data remains constant for subsequent clocks.
3. Address A19 must be managed as part of a full depth counter implementation using the IDT70T3509M. For physical addresses 00000H through 7FFFFH the value of A19 is 0, while for physical addresses 80000H through FFFFFH the value of A19 is 1. The user needs to keep track of the device counter and make sure that A19 is actively driven from 0-to-1 or 1-to-0 and held as needed at the appropriate address boundaries for full depth counter operation. As shown this transition reflects  $A_n = 7FFFFH$  or  $FFFFFH$ .

## Timing Waveform of Write with Address Counter Advance (Flow-through or Pipelined Inputs)<sup>(1)</sup>

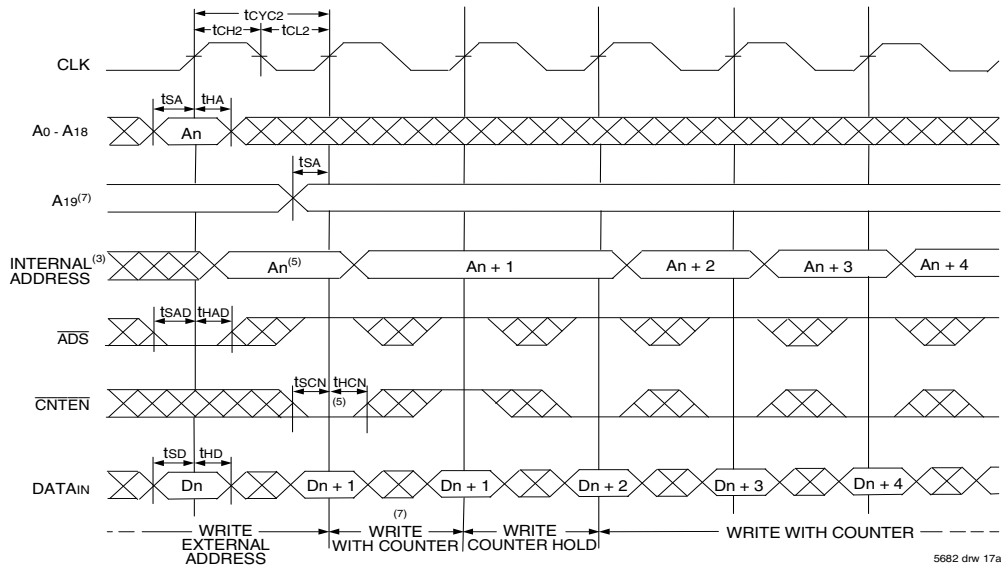

5682 drw 17a

## Timing Waveform of Counter Repeat<sup>(2,6)</sup>

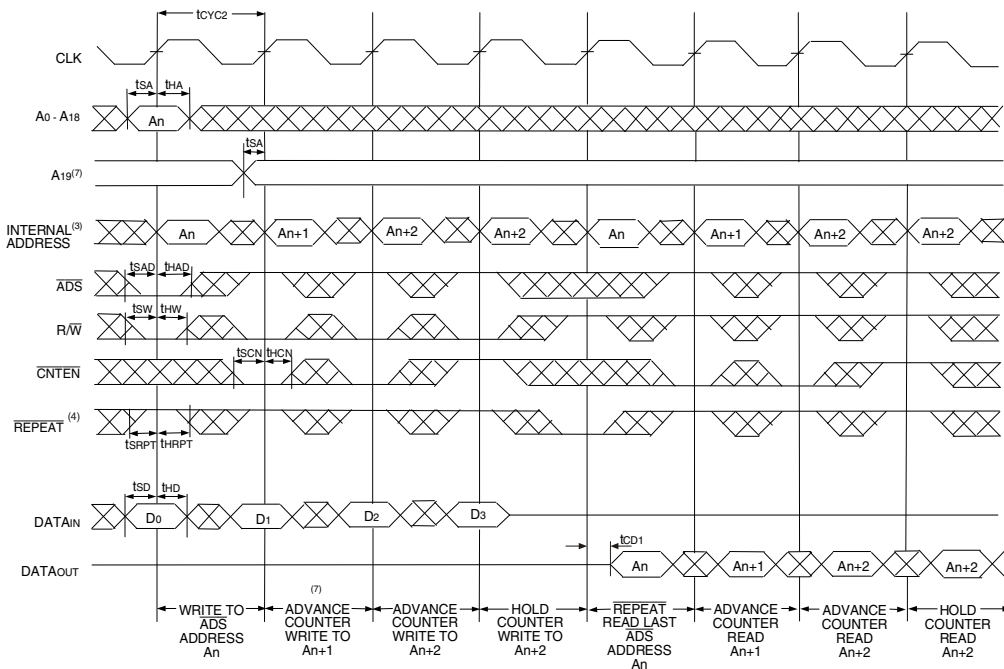

5682 drw 18a

**NOTES:**

1.  $\overline{CE}_0$ ,  $\overline{BE}_n$ , and  $R/\overline{W} = V_{IL}$ ;  $CE_1$  and  $\overline{REPEAT} = V_{IH}$ .
2.  $\overline{CE}_0$ ,  $\overline{BE}_n = V_{IL}$ ;  $CE_1 = V_{IH}$ .
3. The "Internal Address" is equal to the "External Address" when  $\overline{ADS} = V_{IL}$  and equals the counter output when  $\overline{ADS} = V_{IH}$ .
4. No dead cycle exists during  $\overline{REPEAT}$  operation. A READ or WRITE cycle may be coincidental with the counter  $\overline{REPEAT}$  cycle: Address loaded by last valid  $\overline{ADS}$  load will be accessed. For more information on  $\overline{REPEAT}$  function refer to Truth Table II. A19 must be in the appropriate state when using the  $\overline{REPEAT}$  function to guarantee the correct address location is loaded.
5.  $\overline{CNTEN} = V_{IL}$  advances Internal Address from 'An' to 'An +1'. The transition shown indicates the time required for the counter to advance. The 'An +1' Address is written to during this cycle.
6. For Pipelined Mode user should add 1 cycle latency for outputs as per timing waveform of read cycle for pipelined operations.
7. Address A19 must be managed as part of a full depth counter implementation using the IDT70T3509M. For physical addresses 00000H through 7FFFFH the value of A19 is 0, while for physical addresses 80000H through FFFFFH the value of A19 is 1. The user needs to keep track of the device counter and make sure that A19 is actively driven from 0-to-1 or 1-to-0 and held as needed at the appropriate address boundaries for full depth counter operation. As shown this transition reflects  $An = 7FFFFH$  or  $FFFFFH$ .



Waveform of Interrupt Timing<sup>(2)</sup>

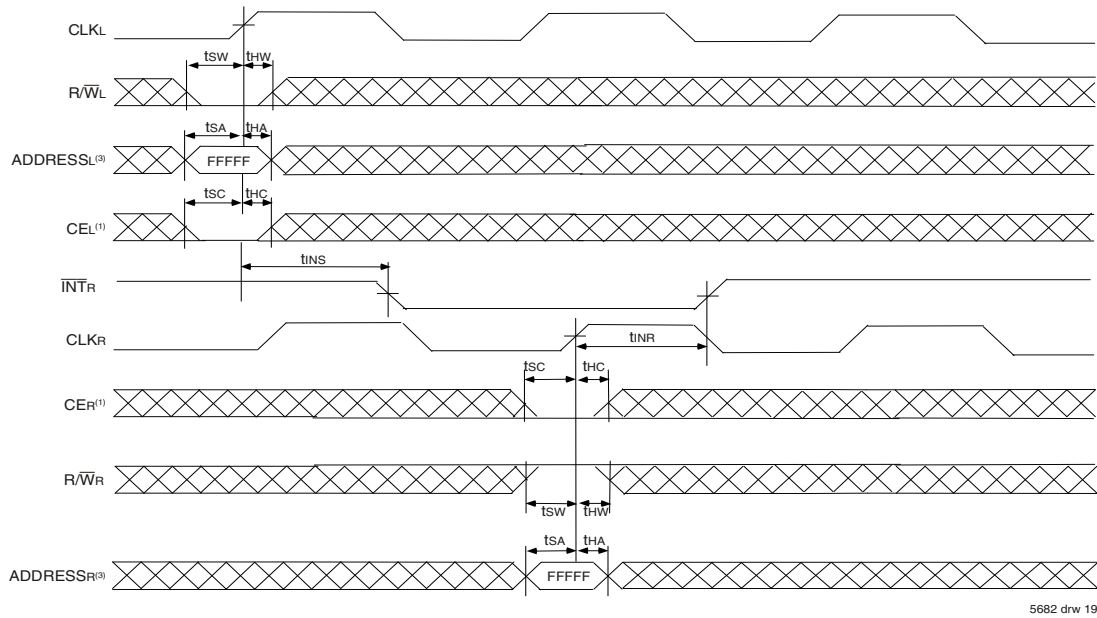

NOTES:

1.  $\overline{CE}_0 = V_{IL}$  and  $CE_1 = V_{IH}$ .
2. All timing is the same for Left and Right ports.
3. Address is for internal register, not the external bus, i.e. address needs to be qualified by one of the Address counter control signals.

Truth Table III - Interrupt Flag<sup>(1)</sup>

Left Port					Right Port					Function
CLKL	R/WL <sup>(2)</sup>	CEL <sup>(2)</sup>	A19L-A0L	$\overline{INT}_L$	CLKR	R/WR <sup>(2)</sup>	CER <sup>(2)</sup>	A19R-A0R	$\overline{INT}_R$	
↑	L	L	FFFFF	X	↑	X	X	X	L	Set Right $\overline{INT}_R$ Flag
↑	X	X	X	X	↑	H	L	FFFFF	H	Reset Right $\overline{INT}_R$ Flag
↑	X	X	X	L	↑	L	L	FFFFE	X	Set Left $\overline{INT}_L$ Flag
↑	H	L	FFFFE	H	↑	X	X	X	X	Reset Left $\overline{INT}_L$ Flag

5682 tbl 12

NOTES:

1.  $\overline{INT}_L$  and  $\overline{INT}_R$  must be initialized at power-up by Resetting the flags.
2.  $\overline{CE}_0 = V_{IL}$  and  $CE_1 = V_{IH}$ , R/W and CE are synchronous with respect to the clock and need valid set-up and hold times.
3. Address is for internal register, not the external bus, i.e. address needs to be qualified by one of the Address counter control signals.

### Timing Waveform - Entering Sleep Mode (1,2)

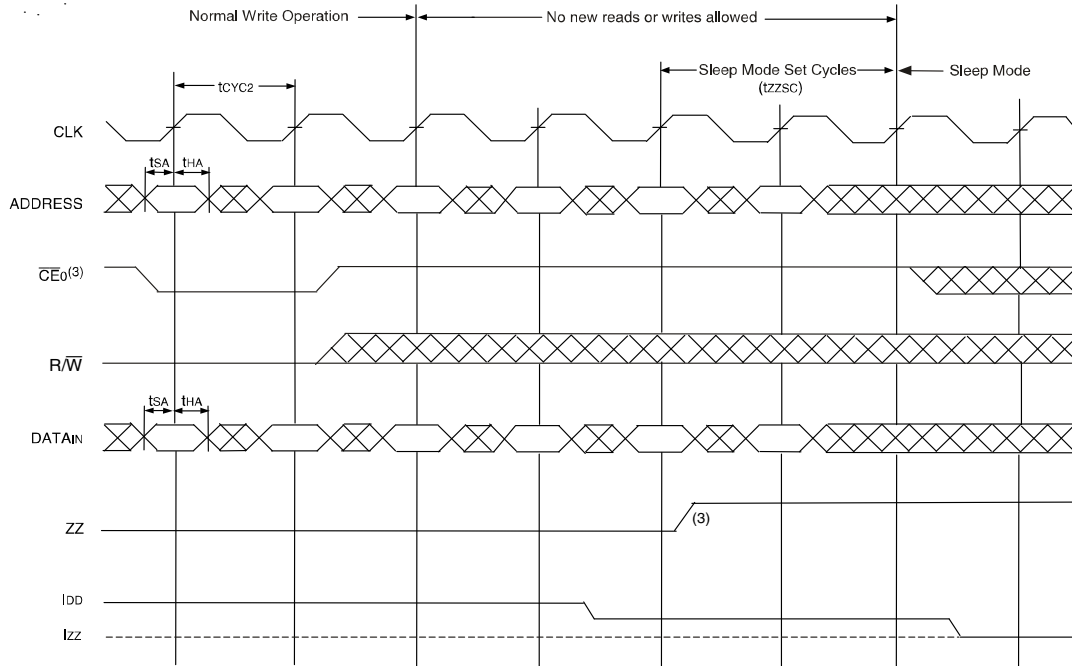

5682 drw 22

### Timing Waveform - Exiting Sleep Mode (1,2)

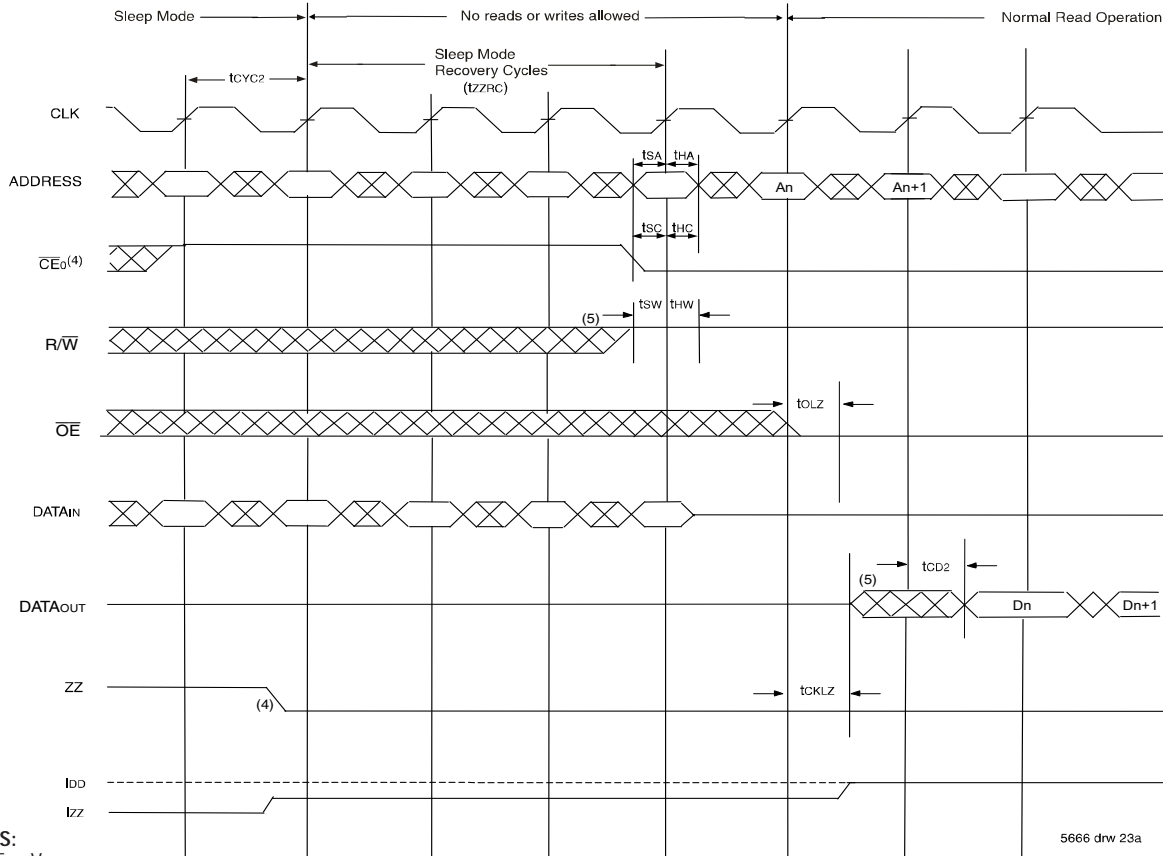

5666 drw 23a

**NOTES:**

1. CE1 = VIH.
2. All timing is same for Left and Right ports.
3. CE0 has to be deactivated (CE0 = VIH) three cycles prior to asserting ZZ (ZZx = VIH) and held for two cycles after asserting ZZ (ZZx = VIH).
4. CE0 has to be deactivated (CE0 = VIH) one cycle prior to de-asserting ZZ (ZZx = VIL) and held for three cycles after de-asserting ZZ (ZZx = VIL).
5. The device must be in Read Mode (R/W High) when exiting sleep mode. Outputs are active but data is not valid until the following cycle.

## Functional Description

The IDT70T3509M provides a true synchronous Dual-Port Static RAM interface. Registered inputs provide minimal set-up and hold times on address, data, and all critical control inputs. All internal registers are clocked on the rising edge of the clock signal, however, the self-timed internal write pulse width is independent of the cycle time.

An asynchronous output enable is provided to ease asynchronous bus interfacing. Counter enable inputs are also provided to stall the operation of the address counters for fast interleaved memory applications.

The combination of a HIGH on  $\overline{CE0}$  and a LOW on  $CE1$  for one clock cycle will power down the internal circuitry to reduce static power consumption. Multiple chip enables allow easier banking of multiple IDT70T3509Ms for depth expansion configurations. Two cycles are required with  $\overline{CE0}$  LOW and  $CE1$  HIGH to reactivate the outputs.

## Width Expansion

The IDT70T3509M can be used in applications requiring expanded width. Through combining the control signals, the devices can be grouped as necessary to accommodate applications needing 72-bits or wider.

## Sleep Mode

The IDT70T3509M is equipped with an optional sleep or low power mode on both ports. The sleep mode pin on both ports is asynchronous and active high. During normal operation, the ZZ pin is pulled low. When ZZ is pulled high, the port will enter sleep mode where it will meet lowest possible power conditions. The sleep mode timing diagram shows the modes of operation: Normal Operation, No Read/Write Allowed and Sleep Mode.

For normal operation all inputs must meet setup and hold times prior to sleep and after recovering from sleep. Clocks must also meet cycle high and low times during these periods. Three cycles prior to asserting ZZ ( $ZZx = V_{IH}$ ) and three cycles after de-asserting ZZ ( $ZZx = V_{IL}$ ), the device must be disabled via the chip enable pins. If a write or read operation occurs during these periods, the memory array may be corrupted. Validity of data out from the RAM cannot be guaranteed immediately after ZZ is asserted (prior to being in sleep). When exiting sleep mode, the device must be in Read mode ( $R/\overline{W}x = V_{IH}$ ) when chip enable is asserted, and the chip enable must be valid for one full cycle before a read will result in the output of valid data.

During sleep mode the RAM automatically deselects itself. The RAM disconnects its internal clock buffer. The external clock may continue to run without impacting the RAM's sleep current ( $I_{ZZ}$ ). All outputs will remain in high-Z state while in sleep mode. All inputs are allowed to toggle. The RAM will not be selected and will not perform any reads or writes.

### JTAG Functionality and Configuration

The IDT70T3509M is composed of four independent memory arrays, and thus cannot be treated as a single JTAG device in the scan chain. The four arrays (A, B, C and D) each have identical characteristics and commands but must be treated as separate entities in JTAG operations. Please refer to Figure 2.

JTAG signaling must be provided serially to each array and utilize the information provided in the Identification Register Definitions, Scan

Register Sizes, and System Interface Parameter tables. Specifically, all serial commands must be issued to the IDT70T3509M in the following sequence: Array D, Array C, Array B, Array A. Please reference Application Note AN-411, "JTAG Testing of Multichip Modules" for specific instructions on performing JTAG testing on the IDT70T3509M. AN-411 is available at [www.idt.com](http://www.idt.com).

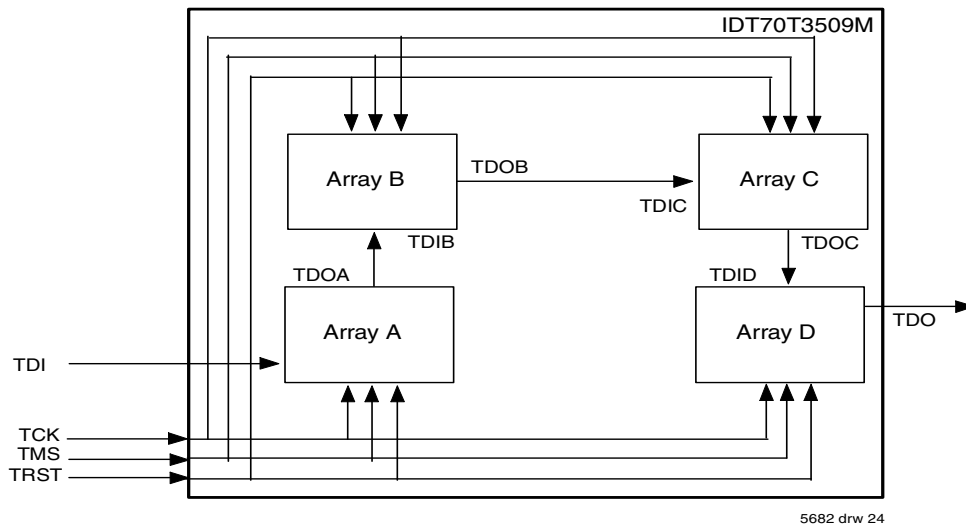

Figure 2. JTAG Configuration for IDT70T3509M

### JTAG Timing Specifications

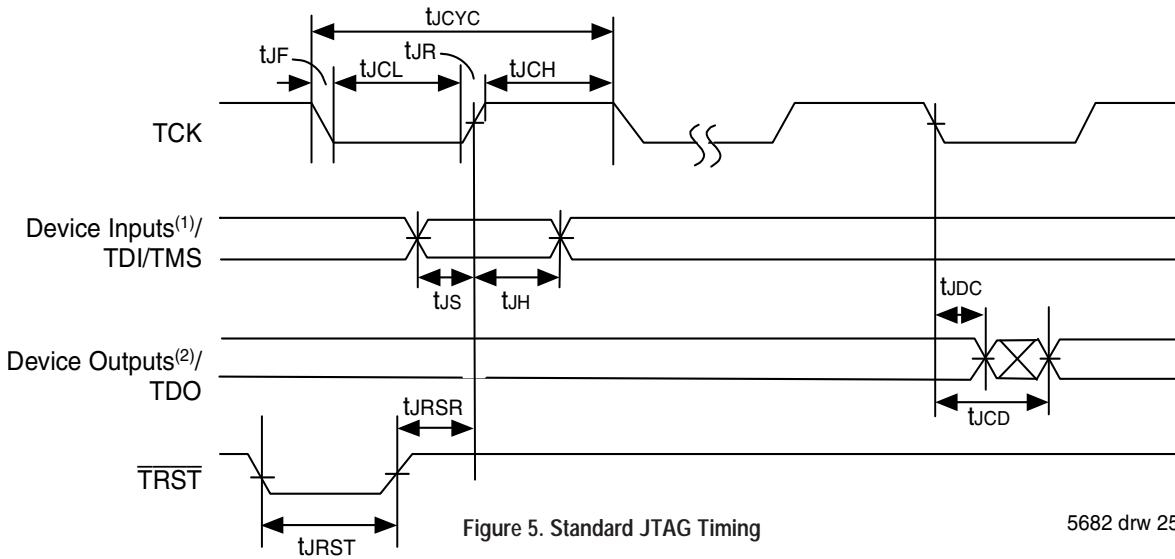

Figure 5. Standard JTAG Timing

5682 drw 25

**NOTES:**

1. Device inputs = All device inputs except TDI, TMS, and TRST.
2. Device outputs = All device outputs except TDO.

### JTAG AC Electrical Characteristics <sup>(1,2,3,4)</sup>

Symbol	Parameter	70T3509M		
		Min.	Max.	Units
t <sub>JCYC</sub>	JTAG Clock Input Period	100	—	ns
t <sub>JCH</sub>	JTAG Clock HIGH	40	—	ns
t <sub>JCL</sub>	JTAG Clock Low	40	—	ns
t <sub>JR</sub>	JTAG Clock Rise Time	—	3 <sup>(1)</sup>	ns
t <sub>JF</sub>	JTAG Clock Fall Time	—	3 <sup>(1)</sup>	ns
t <sub>JRST</sub>	JTAG Reset	50	—	ns
t <sub>JRSR</sub>	JTAG Reset Recovery	50	—	ns
t <sub>JCD</sub>	JTAG Data Output	—	25	ns
t <sub>JDC</sub>	JTAG Data Output Hold	0	—	ns
t <sub>JS</sub>	JTAG Setup	15	—	ns
t <sub>JH</sub>	JTAG Hold	15	—	ns

5682 tbl 15

**NOTES:**

1. Guaranteed by design.
2. 30pF loading on external output signals.
3. Refer to AC Electrical Test Conditions stated earlier in this document.
4. JTAG operations occur at one speed (10MHz). The base device may run at any speed specified in this datasheet.

## Identification Register Definitions

Instruction Field Array D	Value Array D	Instruction Field Array C	Value Array C	Instruction Field Array B	Value Array B	Instruction Field Array A	Value Array A	Description
Revision Number (31:28)	0x0	Revision Number (63:60)	0x0	Revision Number (95:92)	0x0	Revision Number (127:124)	0x0	Reserved for Version number
IDT Device ID (27:12)	0x333	IDT Device ID (59:44)	0x333	IDT Device ID (91:76)	0x333	IDT Device ID (123:108)	0x333	Defines IDT Part number
IDT JEDEC ID (11:1)	0x33	IDT JEDEC ID (43:33)	0x33	IDT JEDEC ID (75:65)	0x33	IDT JEDEC ID (107:97)	0x33	Allows unique identification of device vendor as IDT
ID Register Indicator Bit (Bit 0)	1	ID Register Indicator Bit (Bit 32)	1	ID Register Indicator Bit (Bit 64)	1	ID Register Indicator Bit (Bit 96)	1	Indicates the presence of an ID Register

5682 tbl 16

## Scan Register Sizes

Register Name	Bit Size Array A	Bit Size Array B	Bit Size Array C	Bit Size Array D	Bit Size 70T3509M
Instruction (IR)	4	4	4	4	16
Bypass (BYR)	1	1	1	1	4
Identification (IDR)	32	32	32	32	128
Boundary Scan (BSR)	Note (3)	Note (3)	Note (3)	Note (3)	Note (3)

5682 tbl 17

## System Interface Parameters

Instruction	Code	Description
EXTEST	0000000000000000	Forces contents of the boundary scan cells onto the device outputs <sup>(1)</sup> . Places the boundary scan register (BSR) between TDI and TDO.
BYPASS	1111111111111111	Places the bypass register (BYR) between TDI and TDO.
IDCODE	0010001000100010	Loads the ID register (IDR) with the vendor ID code and places the register between TDI and TDO.
HIGHZ	0100010001000100	Places the bypass register (BYR) between TDI and TDO. Forces all device output drivers except INTx to a High-Z state.
CLAMP	0011001100110011	Uses BYR. Forces contents of the boundary scan cells onto the device outputs. Places the bypass register (BYR) between TDI and TDO.
SAMPLE/PRELOAD	0001000100010001	Places the boundary scan register (BSR) between TDI and TDO. SAMPLE allows data from device inputs <sup>(2)</sup> to be captured in the boundary scan cells and shifted serially through TDO. PRELOAD allows data to be input serially into the boundary scan cells via the TDI.
RESERVED	0101010101010101, 0111011101110111, 1000100010001000, 1001100110011001, 1010101010101010, 1011101110111011, 1100110011001100	Several combinations are reserved. Do not use codes other than those identified above.
PRIVATE	0110011001100110, 1101110111011101, 1101101110111011	For internal use only.

5682 tbl 18

### NOTES:

1. Device outputs = All device outputs except TDO.
2. Device inputs = All device inputs except TDI, TMS, and  $\overline{TRST}$ .
3. The Boundary Scan Descriptive Language (BSDL) file for this device is available on the IDT website ([www.idt.com](http://www.idt.com)), or by contacting your local IDT sales representative.

### Ordering Information

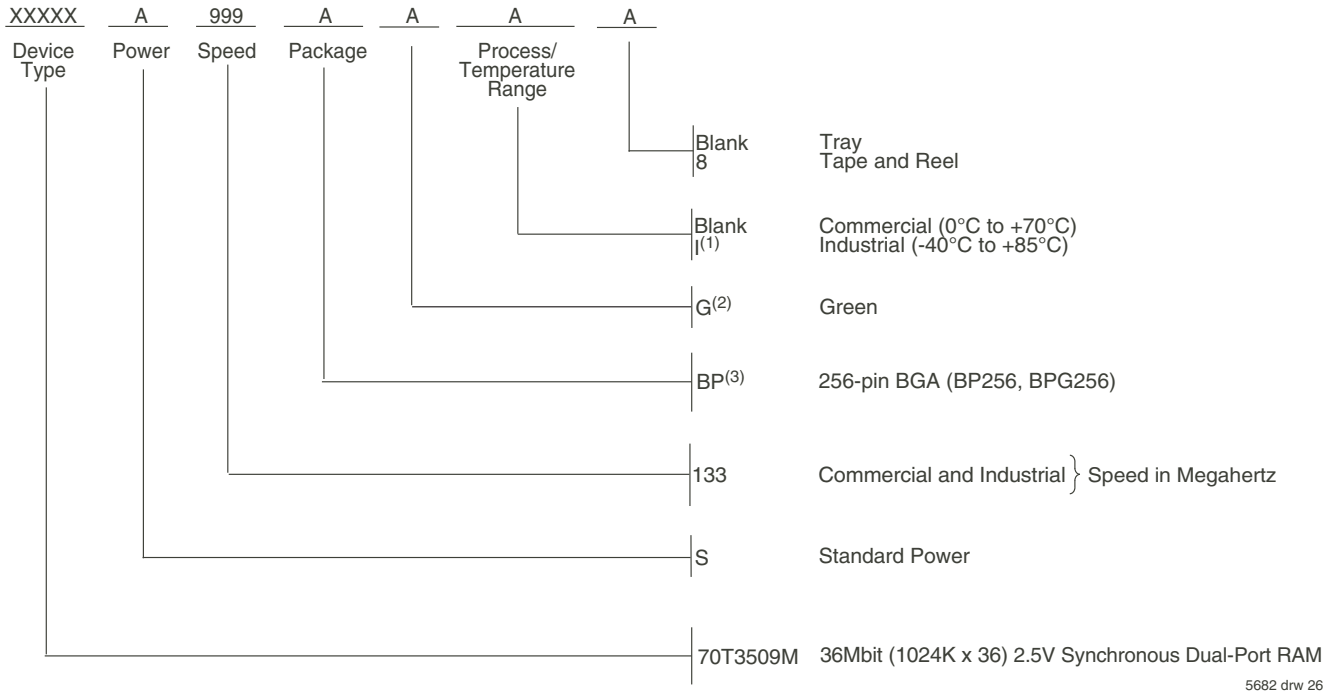

**NOTES:**

1. Contact your local sales office for Industrial temp range in other speeds, packages and powers.
2. Green parts available. For specific speeds, packages and powers contact your local sales office.
3. BP-256 package thickness is 1.76mm nominal. This is thicker than the BC-256 package (1.40mm nominal) used for the lower density IDT dual-port products.

### Orderable Part Information

Speed (MHz)	Orderable Part ID	Pkg. Code	Pkg. Type	Temp. Grade
133	70T3509MS133BP	BP256	CABGA	C
	70T3509MS133BPG	BPG256	CABGA	C
	70T3509MS133BPGI	BPG256	CABGA	I
	70T3509MS133BPI	BP256	CABGA	I

## Datasheet Document History

11/09/04:	Initial Public Release of Preliminary Datasheet
03/24/05:	Page 1 Added I-temp offering to features Page 6 Added I-temp information to the Recommended Operating Temperature and Supply Voltage table Page 8 Added I-temp values to the DC Electrical Characteristics table Page 10 Added I-temp to the heading of the AC Electrical Characteristics table Page 23 Added I-temp to ordering information
	Page 1 Added green availability to features Page 1 - 23 Removed Preliminary status
06/14/05:	Page 1 Added feature to highlight footprint compatibility Page 3 & 23 Added a footnote to highlight package thickness of BP-256 vs. BC-256
08/27/07:	Page 1 Functional Block Diagram changed to correct chip enable logic and added footnote 2 referencing Truth Table I
07/28/08:	Page 8 Corrected a typo in the DC Chars table
01/19/09:	Page 23 Removed "IDT" from orderable part number
07/15/14:	Page 23 Added Tape & Reel to Ordering Information Page 23 Ordering Information restored from 70T3719_99 to 70T3509M
02/14/18:	Product Discontinuation Notice - PDN# SP-17-02 Last time buy expires June 15, 2018
07/09/19:	Page 3 & 23 Updated package code BP-256 to BP256 and BPG256 Page 23 Added Orderable Part Information table
10/29/19:	Page 23 Corrected "ns" to "MHz" in the header of the Orderable Part Information table



## IMPORTANT NOTICE AND DISCLAIMER

RENESAS ELECTRONICS CORPORATION AND ITS SUBSIDIARIES (“RENESAS”) PROVIDES TECHNICAL SPECIFICATIONS AND RELIABILITY DATA (INCLUDING DATASHEETS), DESIGN RESOURCES (INCLUDING REFERENCE DESIGNS), APPLICATION OR OTHER DESIGN ADVICE, WEB TOOLS, SAFETY INFORMATION, AND OTHER RESOURCES “AS IS” AND WITH ALL FAULTS, AND DISCLAIMS ALL WARRANTIES, EXPRESS OR IMPLIED, INCLUDING, WITHOUT LIMITATION, ANY IMPLIED WARRANTIES OF MERCHANTABILITY, FITNESS FOR A PARTICULAR PURPOSE, OR NON-INFRINGEMENT OF THIRD PARTY INTELLECTUAL PROPERTY RIGHTS.

These resources are intended for developers skilled in the art designing with Renesas products. You are solely responsible for (1) selecting the appropriate products for your application, (2) designing, validating, and testing your application, and (3) ensuring your application meets applicable standards, and any other safety, security, or other requirements. These resources are subject to change without notice. Renesas grants you permission to use these resources only for development of an application that uses Renesas products. Other reproduction or use of these resources is strictly prohibited. No license is granted to any other Renesas intellectual property or to any third party intellectual property. Renesas disclaims responsibility for, and you will fully indemnify Renesas and its representatives against, any claims, damages, costs, losses, or liabilities arising out of your use of these resources. Renesas' products are provided only subject to Renesas' Terms and Conditions of Sale or other applicable terms agreed to in writing. No use of any Renesas resources expands or otherwise alters any applicable warranties or warranty disclaimers for these products.

(Rev.1.0 Mar 2020)

### Corporate Headquarters

TOYOSU FORESIA, 3-2-24 Toyosu,  
Koto-ku, Tokyo 135-0061, Japan  
[www.renesas.com](http://www.renesas.com)

### Contact Information

For further information on a product, technology, the most up-to-date version of a document, or your nearest sales office, please visit:  
[www.renesas.com/contact/](http://www.renesas.com/contact/)

### Trademarks

Renesas and the Renesas logo are trademarks of Renesas Electronics Corporation. All trademarks and registered trademarks are the property of their respective owners.