

## General Description

The ICS8S73034I is a high-speed, differential-to-LVPECL clock divider designed for high-performance telecommunication, computing and networking applications. High clock frequency capability and the differential design make the ICS8S73034I an ideal choice for performance clock distribution networks. The device frequency-divides the input clock by ÷2, ÷4 and ÷8. Each frequency-divided clock signal is output at a separate LVPECL output. The differential input pair can be driven by LVPECL, LVDS, CML and SSTL signals. Single-ended input signals are supported by using the integrated bias voltage generator ( $V_{BB}$ ). The ICS8S73034I is optimized for 3.3V and 2.5V power supply voltages and the temperature range of -40 to +85°C. The device is available in space-saving 16-lead TSSOP and SOIC packages.

## Features

- ÷2, ÷4 and ÷8 clock frequency divider
- Three differential LVPECL output pairs
- One differential PCLK, nPCLK input pair
- PCLK, nPCLK pair can accept the following differential input levels: LVPECL, LVDS, CML
- $V_{BB}$  bias voltage generator supports single-ended LVPECL clock input signals
- LVCMOS control inputs
- Maximum input frequency: 3.2GHz
- Translates any single-ended input signal to 3.3V LVPECL levels with bias resistors on nPCLK input
- LVPECL mode operating voltage supply range:  $V_{CC} = 2.375V$  to  $3.8V$ ,  $V_{EE} = 0V$
- -40°C to 85°C ambient operating temperature
- Available in lead-free (RoHS 6) package

## Block Diagram

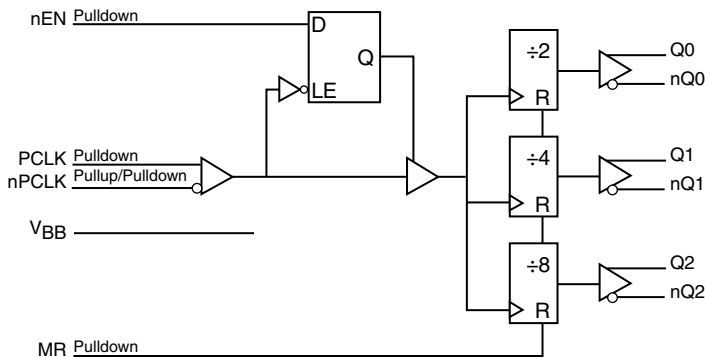

## Pin Assignment

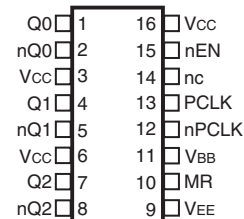

### ICS8S73034I

**16-Lead SOIC, 150 Mil**  
**3.9mm x 9.9mm x 1.375mm package body**  
**M Package**  
**Top View**

**16-Lead TSSOP**  
**4.4mm x 5.0mm x 0.925mm package body**  
**G Package**  
**Top View**

**Table 1. Pin Descriptions**

Number	Name	Type		Description
1, 2	Q0, nQ0	Output		Differential output pair. LVPECL interface levels.
3, 6, 16	V <sub>CC</sub>	Power		Power supply pins.
4, 5	Q1, nQ1	Output		Differential output pair. LVPECL interface levels.
7, 8	Q2, nQ2	Output		Differential output pair. LVPECL interface levels.
9	V <sub>EE</sub>	Power		Negative supply pin.
10	MR	Input	Pulldown	Active High Master Reset. When logic HIGH, the internal dividers are reset causing the true outputs Q <sub>x</sub> to go low and the inverted outputs nQ <sub>x</sub> to go high. When logic LOW, the internal dividers and the outputs are enabled. LVCMOS/LVTTL interface levels.
11	V <sub>BB</sub>	Output		Bias voltage.
12	nPCLK	Input	Pullup/ Pulldown	Inverting differential clock input. Defaults to $\frac{2}{3} * V_{CC}$ when left open. LVPECL interface levels.
13	PCLK	Input	Pulldown	Non-inverting differential clock input. LVPECL interface levels.
14	nc	Unused		No connect.
15	nEN	Input	Pulldown	Synchronous clock enable. When logic LOW, the clock is enabled and frequency-divided. When logic HIGH, the clock is disabled and the outputs remain stopped in the same logic state (hold). LVTTL / LVCMOS interface levels.

NOTE: *Pullup* and *Pulldown* refer to internal input resistors. See Table 2, *Pin Characteristics*, for typical values.

**Table 2. Pin Characteristics**

Symbol	Parameter	Test Conditions	Minimum	Typical	Maximum	Units
R <sub>PULLDOWN</sub>	Input Pulldown Resistor			75		kΩ
R <sub>PULLUP</sub>	Input Pullup Resistor			37.5		kΩ

## Function Table

**Table 3. Truth Table**

Inputs			Function
PCLK	nEN	MR	
↓	L	L	Divide
↑	H	L	Hold Q[0:2]
X	X	H	Reset Q[0:2]

↑ = Rising edge transition

↓ = Falling edge transition

X = Don't care

## Absolute Maximum Ratings

NOTE: Stresses beyond those listed under *Absolute Maximum Ratings* may cause permanent damage to the device. These ratings are stress specifications only. Functional operation of product at these conditions or any conditions beyond those listed in the *DC Characteristics* or *AC Characteristics* is not implied. Exposure to absolute maximum rating conditions for extended periods may affect product reliability.

Item	Rating
Supply Voltage, $V_{CC}$	4.6V (LVPECL mode, $V_{EE} = 0V$ )
Inputs, $V_I$ (LVPECL mode)	-0.5V to $V_{CC} + 0.5V$
Outputs, $I_O$ Continuous Current Surge Current	50mA 100mA
$V_{BB}$ Sink/Source, $I_{BB}$	$\pm 0.5mA$
Operating Temperature Range, $T_A$	-40°C to +85°C
Package Thermal Impedance, $\theta_{JA}$ 16 Lead SOIC, Junction-to-Ambient 16 Lead TSSOP, Junction-to-Ambient	70.2°C/W (0 mps) 100°C/W (0 mps)
Storage Temperature, $T_{STG}$	-65°C to 150°C

## DC Electrical Characteristics

Table 4A. Power Supply DC Characteristics,  $V_{CC} = 2.375V$  to  $3.8V$ ;  $V_{EE} = 0V$ ,  $T_A = -40^\circ C$  to  $85^\circ C$

Symbol	Parameter	Test Conditions	Minimum	Typical	Maximum	Units
$V_{CC}$	Power Supply Voltage		2.375	3.3	3.8	V
$I_{EE}$	Power Supply Current				45	mA

**Table 4B. DC Characteristics,  $V_{CC} = 2.375V$  to  $3.8V$ ,  $V_{EE} = 0V$ ;  $T_A = -40^{\circ}C$  to  $85^{\circ}C$** 

Symbol	Parameter	-40°C			25°C			85°C			Units
		Min	Typ	Max	Min	Typ	Max	Min	Typ	Max	
$V_{OH}$	Output High Voltage; NOTE 1	$V_{CC}-1.070$	$V_{CC}-0.867$	$V_{CC}-0.635$	$V_{CC}-1.070$	$V_{CC}-0.867$	$V_{CC}-0.635$	$V_{CC}-1.070$	$V_{CC}-0.867$	$V_{CC}-0.635$	V
$V_{OL}$	Output Low Voltage; NOTE 1	$V_{CC}-1.960$	$V_{CC}-1.780$	$V_{CC}-1.590$	$V_{CC}-1.960$	$V_{CC}-1.780$	$V_{CC}-1.590$	$V_{CC}-1.960$	$V_{CC}-1.780$	$V_{CC}-1.590$	V
$V_{IH}$	Input High Voltage (Single-ended)	$0.7V_{CC}$		$V_{CC} + 0.3$	$0.7V_{CC}$		$V_{CC} + 0.3$	$0.7V_{CC}$		$V_{CC} + 0.3$	V
$V_{IL}$	Input Low Voltage (Single-ended)	-0.3		$0.3V_{CC}$	-0.3		$0.3V_{CC}$	-0.3		$0.3V_{CC}$	V
$V_{BB}$	Output Voltage Reference	$V_{CC} - 1.44$		$V_{CC} - 1.32$	$V_{CC} - 1.44$		$V_{CC} - 1.32$	$V_{CC} - 1.44$		$V_{CC} - 1.32$	V
$V_{PP}$	Peak-to-Peak Input Voltage	0.15	0.8	1.3	0.15	0.8	1.3	0.15	0.8	1.3	V
$V_{CMR}$	Input High Voltage Common Mode Range; NOTE 2	1.2		$V_{CC}$	1.2		$V_{CC}$	1.2		$V_{CC}$	V
$I_{IH}$	Input High Current			150			150			150	$\mu A$
$I_{IL}$	Input Low Current	PCLK, MR, nEN	-10		-10		-10		-10		$\mu A$
		nPCLK	-150		-150		-150		-150		$\mu A$

NOTE Input and output parameters vary 1:1 with  $V_{CC}$ .

NOTE 1: Outputs terminated with  $50\Omega$  to  $V_{CC} - 2V$ .

NOTE 2: Common mode voltage is defined as  $V_{IH}$ .

## AC Electrical Characteristics

**Table 5. AC Characteristics,  $V_{CC} = 2.375V$  to  $3.8V$ ,  $V_{EE} = 0V$ ;  $T_A = -40^{\circ}C$  to  $85^{\circ}C$**

Symbol	Parameter		-40°C			25°C			85°C			Units
			Min	Typ	Max	Min	Typ	Max	Min	Typ	Max	
$f_{IN}$	Input Frequency				3.2			3.2			3.2	GHz
$f_{OUT}$	Output Frequency	Q0, nQ0			1.6			1.6			1.6	GHz
		Q1, nQ1			800			800			800	MHz
		Q2, nQ2			400			400			400	MHz
$t_{PD}$	Propagation Delay; NOTE 1		270	370	470	310	410	510	330	450	565	ps
$t_{sk(o)}$	Output Skew; NOTE 2				50			50			50	ps
$t_{RR}$	Set/Reset Recovery			320	500		320	500		320	500	ps
$t_S$	Setup Time	nEN			400			400			400	ps
$t_H$	Hold Time	nEN			200			200			200	ps
$t_R / t_F$	Output Rise/Fall Time	20% to 80%	80	145	210	85	150	215	100	165	230	ps
odc	Output Duty Cycle		48		52	48		52	48		52	%

NOTE: Electrical parameters are guaranteed over the specified ambient operating temperature range, which is established when the device is mounted in a test socket with maintained transverse airflow greater than 500 lfm. The device will meet specifications after thermal equilibrium has been reached under these conditions.

All parameters are measured at  $f_{IN} \leq 1.5GHz$ , unless otherwise noted.

NOTE 1: Measured from the differential input crossing point to the differential output crossing point.

NOTE 2: Output skew at coincident rising edges.

## Parameter Measurement Information

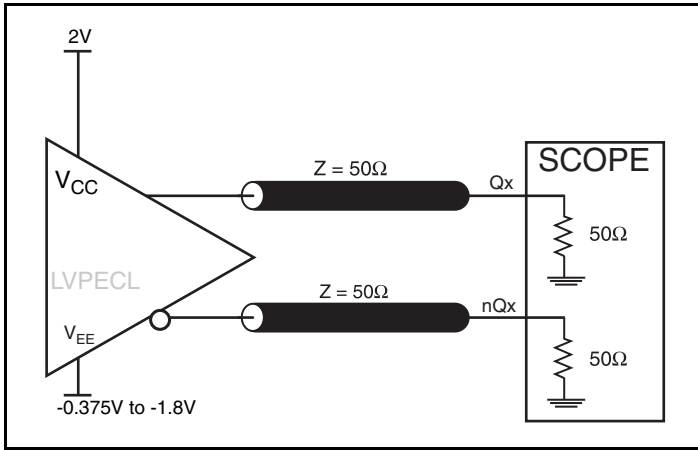

LVPECL Output Load AC Test Circuit

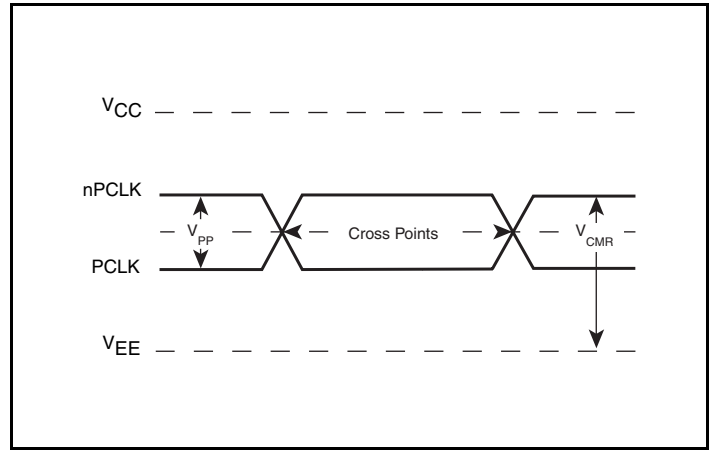

Differential Input Level

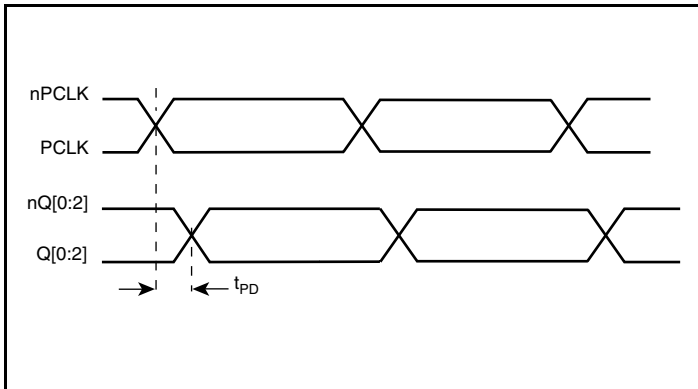

Propagation Delay

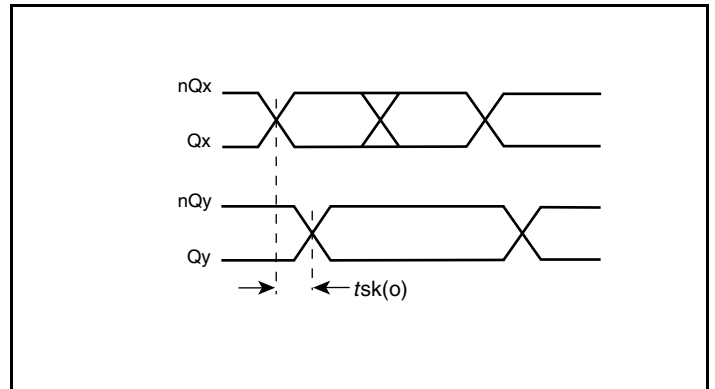

Output Skew

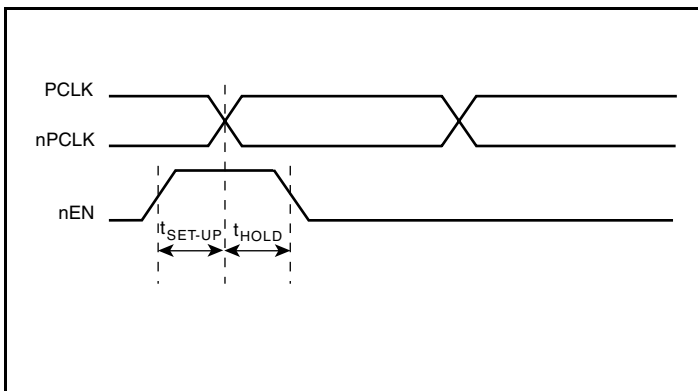

Setup and Hold Time

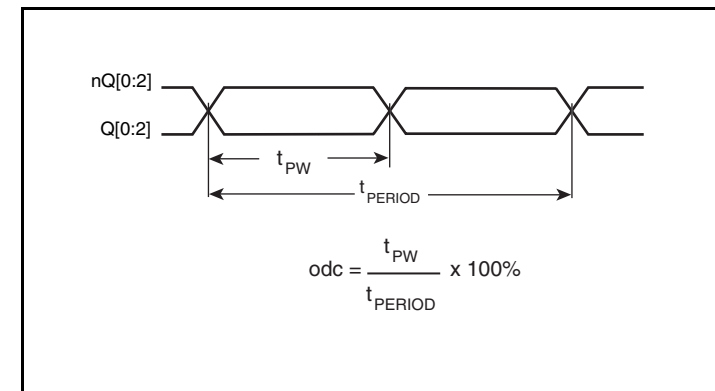

Output Duty Cycle

## Parameter Measurement Information, continued

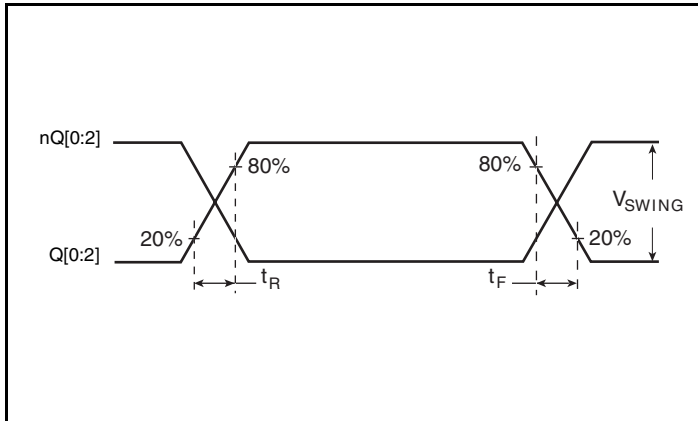

Output Rise/Fall Time

## Application Information

### Recommendations for Unused Output Pins

#### Inputs:

##### LVC MOS Control Pins

All control pins have internal pulldowns; additional resistance is not required but can be added for additional protection. A  $1k\Omega$  resistor can be used.

#### Outputs:

##### LVPECL Outputs

All unused LVPECL outputs can be left floating. We recommend that there is no trace attached. Both sides of the differential output pair should either be left floating or terminated.

## Wiring the Differential Input to Accept Single-Ended Levels

Figure 1 shows how a differential input can be wired to accept single ended levels. The reference voltage  $V_{REF} = V_{CC}/2$  is generated by the bias resistors R1 and R2. The bypass capacitor (C1) is used to help filter noise on the DC bias. This bias circuit should be located as close to the input pin as possible. The ratio of R1 and R2 might need to be adjusted to position the  $V_{REF}$  in the center of the input voltage swing. For example, if the input clock swing is 2.5V and  $V_{CC} = 3.3V$ , R1 and R2 value should be adjusted to set  $V_{REF}$  at 1.25V. The values below are for when both the single ended swing and  $V_{CC}$  are at the same voltage. This configuration requires that the sum of the output impedance of the driver ( $R_o$ ) and the series resistance ( $R_s$ ) equals the transmission line impedance. In addition, matched termination at the input will attenuate the signal in half. This can be done in one of two ways. First, R3 and R4 in parallel should equal the transmission

line impedance. For most 50Ω applications, R3 and R4 can be 100Ω. The values of the resistors can be increased to reduce the loading for slower and weaker LVCMOS driver. When using single-ended signaling, the noise rejection benefits of differential signaling are reduced. Even though the differential input can handle full rail LVCMOS signaling, it is recommended that the amplitude be reduced. The datasheet specifies a lower differential amplitude, however this only applies to differential signals. For single-ended applications, the swing can be larger, however  $V_{IL}$  cannot be less than -0.3V and  $V_{IH}$  cannot be more than  $V_{CC} + 0.3V$ . Though some of the recommended components might not be used, the pads should be placed in the layout. They can be utilized for debugging purposes. The datasheet specifications are characterized and guaranteed by using a differential signal.

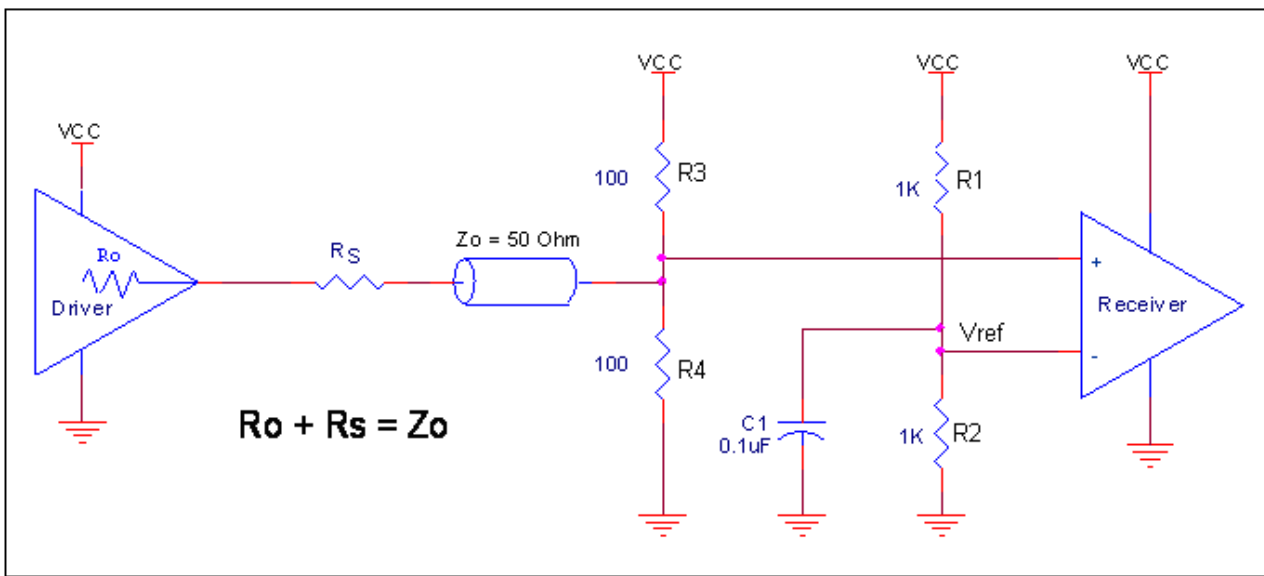

Figure 1. Recommended Schematic for Wiring a Differential Input to Accept Single-ended Levels



### 3.3V LVPECL Clock Input Interface

The PCLK/nPCLK accepts LVPECL, LVDS, CML and other differential signals. Both  $V_{SWING}$  and  $V_{OH}$  must meet the  $V_{PP}$  and  $V_{CMR}$  input requirements. Figures 2A to 2E show interface examples for the PCLK/nPCLK input driven by the most common driver types.

The input interfaces suggested here are examples only. If the driver is from another vendor, use their termination recommendation. Please consult with the vendor of the driver component to confirm the driver termination requirements.

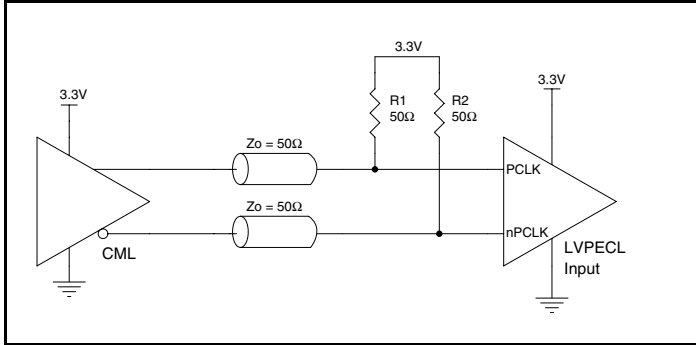

Figure 2A. PCLK/nPCLK Input Driven by a CML Driver

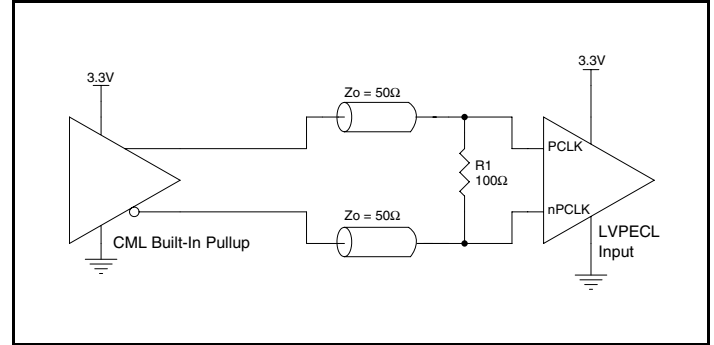

Figure 2B. PCLK/nPCLK Input Driven by a Built-In Pullup CML Driver

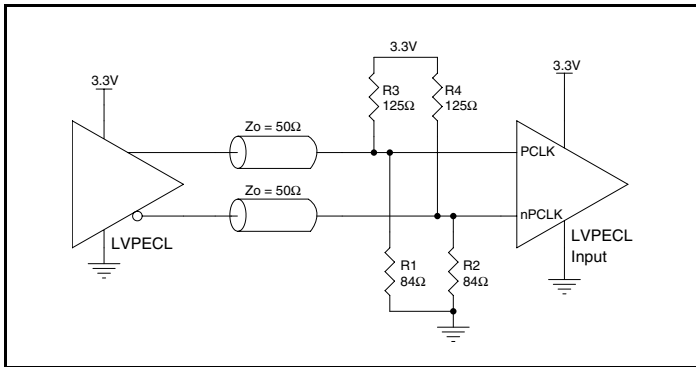

Figure 2C. PCLK/nPCLK Input Driven by a 3.3V LVPECL Driver

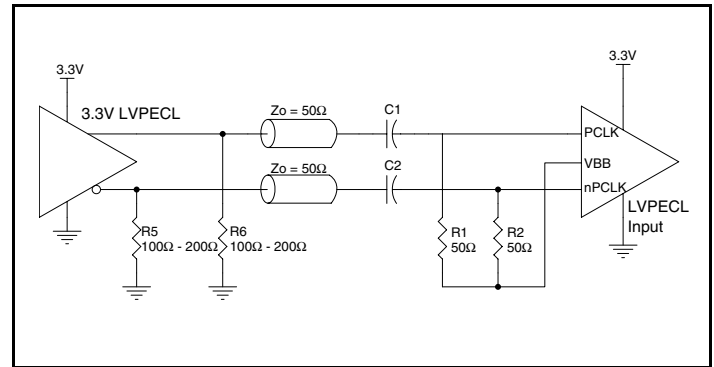

Figure 2D. PCLK/nPCLK Input Driven by a 3.3V LVPECL Driver with AC Couple

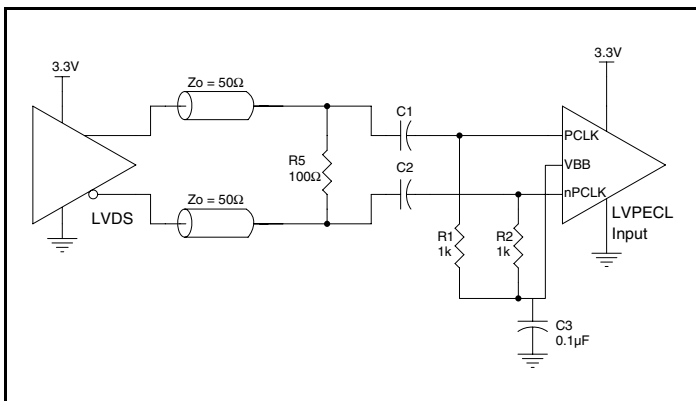
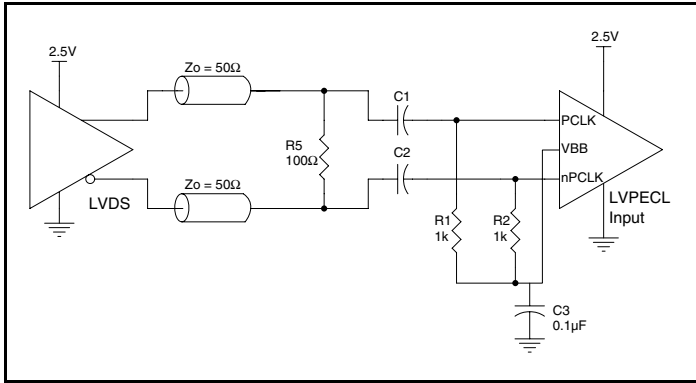

Figure 2E. PCLK/nPCLK Input Driven by a 3.3V LVDS Driver

## 2.5V LVPECL Clock Input Interface

The PCLK /nPCLK accepts LVPECL, LVDS, CML and other differential signals. The differential signal must meet the  $V_{PP}$  and  $V_{CMR}$  input requirements. *Figures 3A to 3E* show interface examples for the PCLK/nPCLK input driven by the most common driver types.

The input interfaces suggested here are examples only. If the driver is from another vendor, use their termination recommendation. Please consult with the vendor of the driver component to confirm the driver termination requirements.



**Figure 3A. PCLK/nPCLK Input Driven by a 2.5V LVDS Driver**

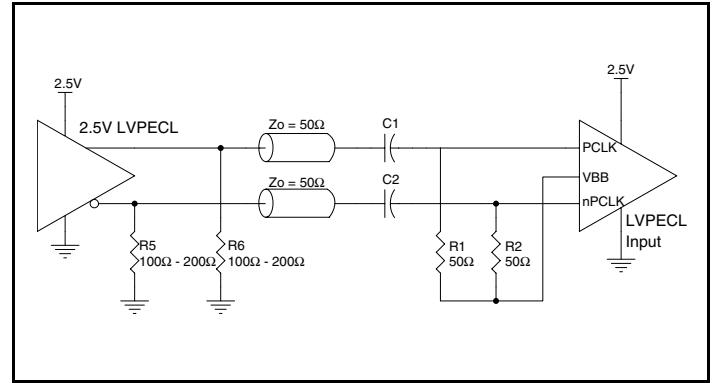

**Figure 3B. PCLK/nPCLK Input Driven by a 3.3V LVPECL Driver with AC Couple**

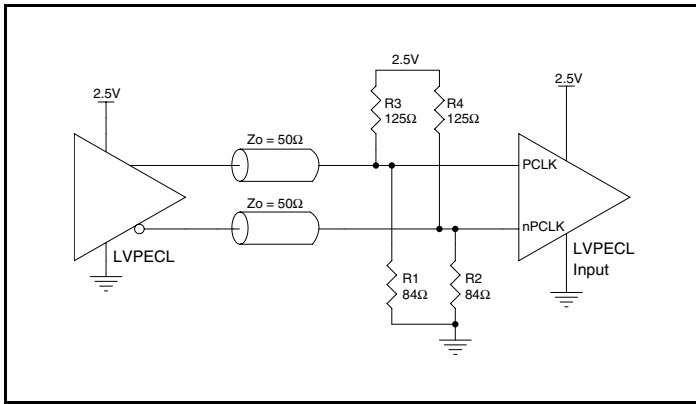

**Figure 3C. PCLK/nPCLK Input Driven by a 2.5V LVPECL Driver**

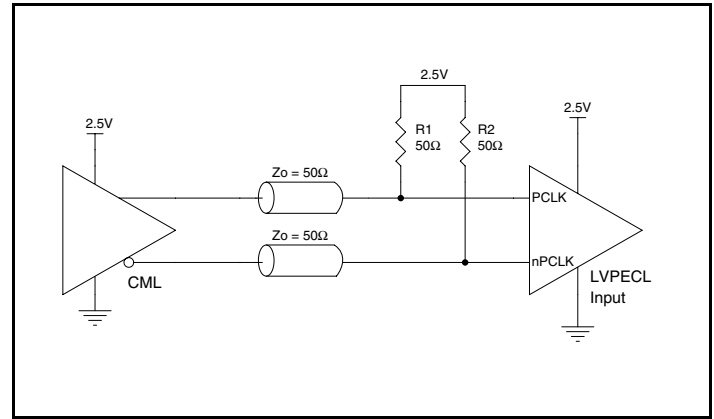

**Figure 3D. PCLK/nPCLK Input Driven by a CML Driver**

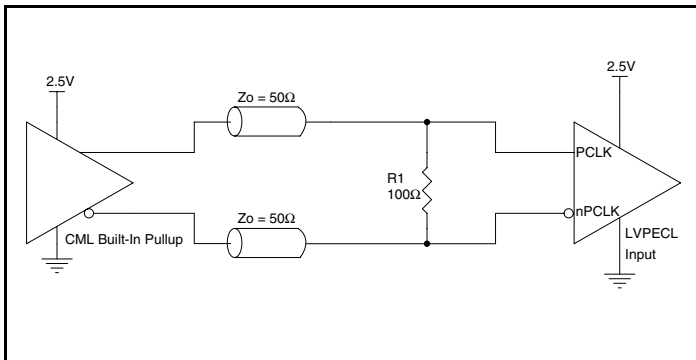

**Figure 3E. PCLK/nPCLK Input Driven by a Built-In Pullup CML Driver**

## Termination for 3.3V LVPECL Outputs

The clock layout topology shown below is a typical termination for LVPECL outputs. The two different layouts mentioned are recommended only as guidelines.

The differential outputs are low impedance follower outputs that generate ECL/LVPECL compatible outputs. Therefore, terminating resistors (DC current path to ground) or current sources must be used for functionality. These outputs are designed to drive 50Ω

transmission lines. Matched impedance techniques should be used to maximize operating frequency and minimize signal distortion.

Figures 4A and 4B show two different layouts which are recommended only as guidelines. Other suitable clock layouts may exist and it would be recommended that the board designers simulate to guarantee compatibility across all printed circuit and clock component process variations.

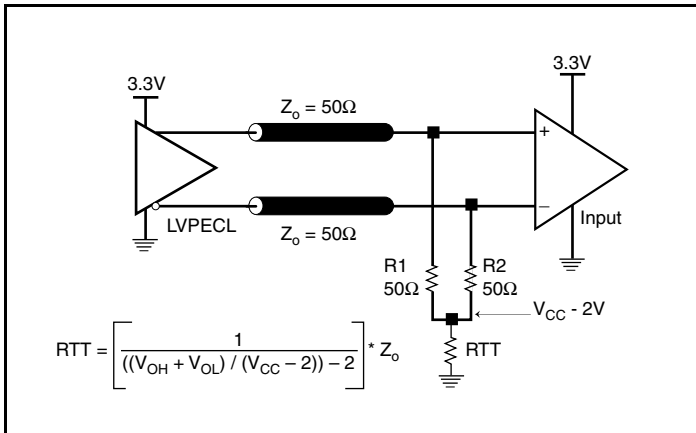

Figure 4A. 3.3V LVPECL Output Termination

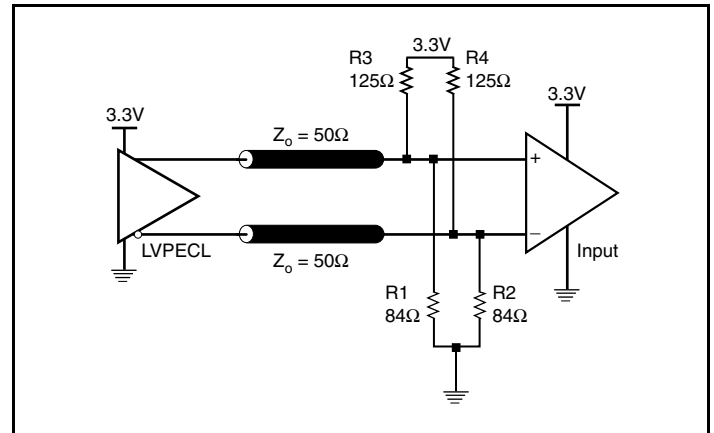

Figure 4B. 3.3V LVPECL Output Termination

## Termination for 2.5V LVPECL Outputs

Figure 5A and Figure 5B show examples of termination for 2.5V LVPECL driver. These terminations are equivalent to terminating  $50\Omega$  to  $V_{CC} - 2V$ . For  $V_{CC} = 2.5V$ , the  $V_{CC} - 2V$  is very close to ground

level. The R3 in Figure 5B can be eliminated and the termination is shown in Figure 5C.

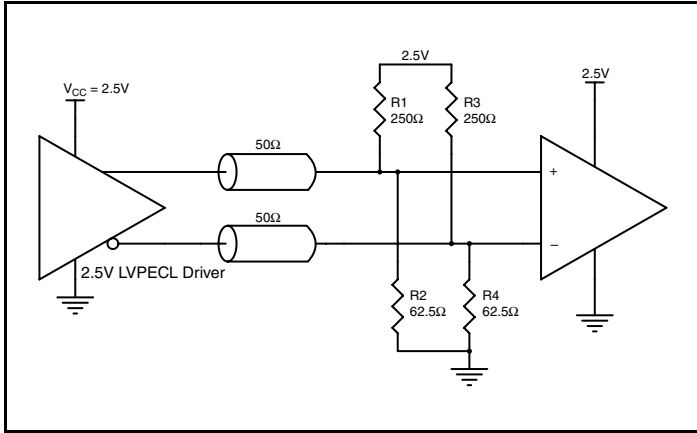

Figure 5A. 2.5V LVPECL Driver Termination Example

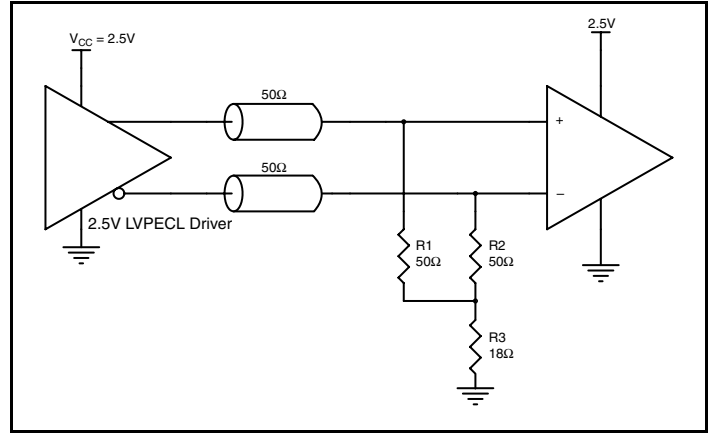

Figure 5B. 2.5V LVPECL Driver Termination Example

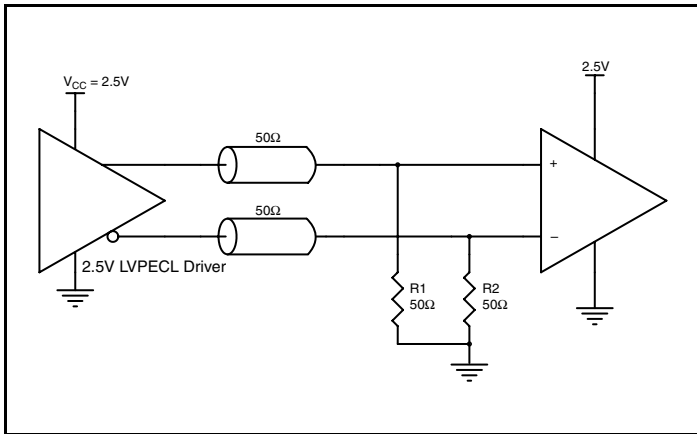

Figure 5C. 2.5V LVPECL Driver Termination Example

## Application Schematic Example

Figure 6 shows an example of ICS8S73034I application schematic. In this example, the device is operated at  $V_{CC} = 3.3V$ . The decoupling capacitor should be located as close as possible to the power pin. The input is driven by a 3.3V LVPECL driver. For the LVPECL output

drivers, only two terminations examples are shown in this schematic. More termination approaches are shown in the LVPECL Termination Application Note.

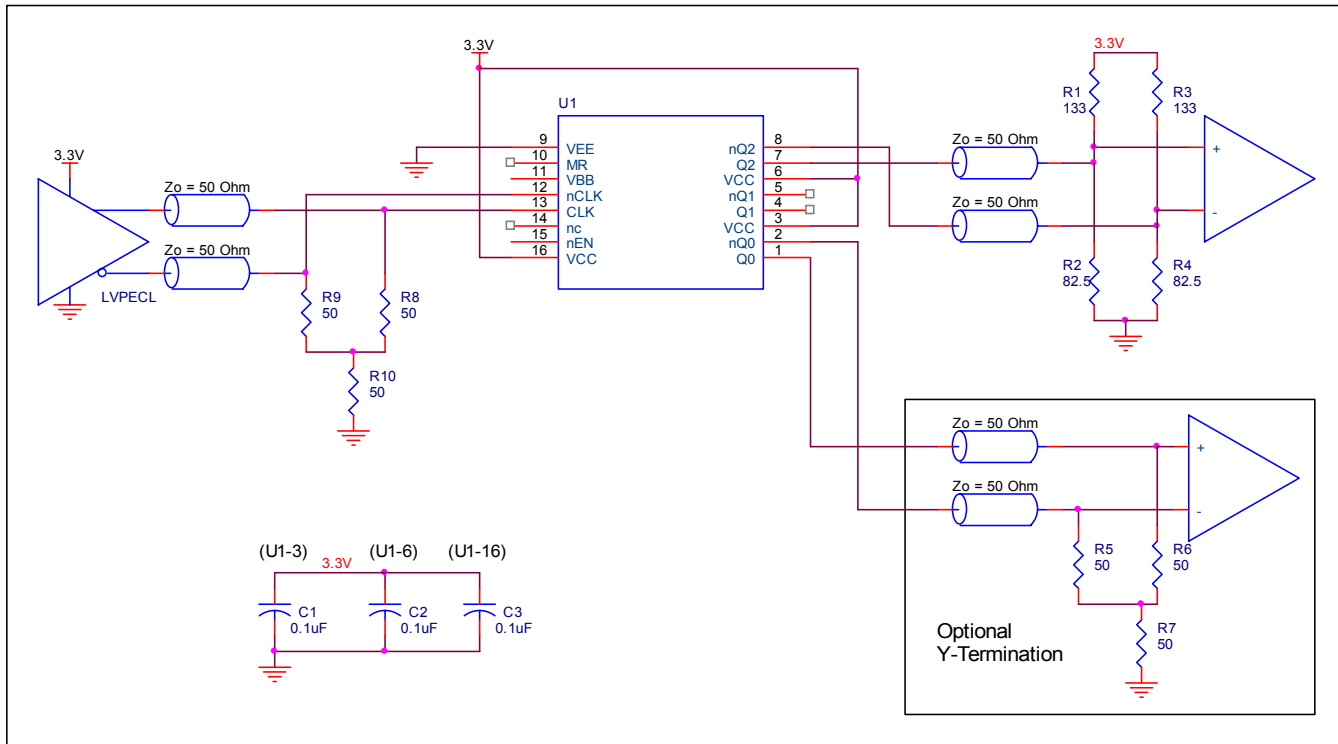

Figure 6. ICS8S73034I Application Schematic Example

## Power Considerations

This section provides information on power dissipation and junction temperature for the ICS8S73034I. Equations and example calculations are also provided.

### 1. Power Dissipation.

The total power dissipation for the ICS8S73034I is the sum of the core power plus the power dissipated in the load(s). The following is the power dissipation for  $V_{CC} = 3.8V$ , which gives worst case results.

NOTE: Please refer to Section 3 for details on calculating power dissipated in the load.

- Power (core)<sub>MAX</sub> =  $V_{CC\_MAX} * I_{EE\_MAX} = 3.8V * 45mA = 171mW$
- Power (outputs)<sub>MAX</sub> = **30.3mW/Loaded Output pair**  
If all outputs are loaded, the total power is  $3 * 30.3mW = 90.9mW$

**Total Power<sub>MAX</sub>** (3.8V, with all outputs switching) =  $171mW + 90.9mW = 261.9mW$

### 2. Junction Temperature.

Junction temperature,  $T_j$ , is the temperature at the junction of the bond wire and bond pad directly affects the reliability of the device. The maximum recommended junction temperature is 125°C. Limiting the internal transistor junction temperature,  $T_j$ , to 125°C ensures that the bond wire and bond pad temperature remains below 125°C.

The equation for  $T_j$  is as follows:  $T_j = \theta_{JA} * Pd\_total + T_A$

$T_j$  = Junction Temperature

$\theta_{JA}$  = Junction-to-Ambient Thermal Resistance

$Pd\_total$  = Total Device Power Dissipation (example calculation is in section 1 above)

$T_A$  = Ambient Temperature

In order to calculate junction temperature, the appropriate junction-to-ambient thermal resistance  $\theta_{JA}$  must be used. Assuming no air flow and a multi-layer board, the appropriate value is 100°C/W per Table 6B below.

Therefore,  $T_j$  for an ambient temperature of 85°C with all outputs switching is:

$$85^\circ C + 0.262W * 100^\circ C/W = 111.2^\circ C. \text{ This is below the limit of } 125^\circ C.$$

This calculation is only an example.  $T_j$  will obviously vary depending on the number of loaded outputs, supply voltage, air flow and the type of board (multi-layer).

**Table 6A. Thermal Resistance  $\theta_{JA}$  for 16 Lead SOIC Forced Convection**

$\theta_{JA}$ by Velocity			
Meters per Second	0	1	2.5
Multi-Layer PCB, JEDEC Standard Test Boards	70.2°C/W	64.7°C/W	61.6°C/W

**Table 6B. Thermal Resistance  $\theta_{JA}$  for 16 Lead TSSOP Forced Convection**

$\theta_{JA}$ by Velocity			
Meters per Second	0	1	2.5
Multi-Layer PCB, JEDEC Standard Test Boards	100.0°C/W	94.2°C/W	90.2°C/W

### 3. Calculations and Equations.

The purpose of this section is to calculate the power dissipation for the LVPECL output pair.

LVPECL output driver circuit and termination are shown in *Figure 7*.

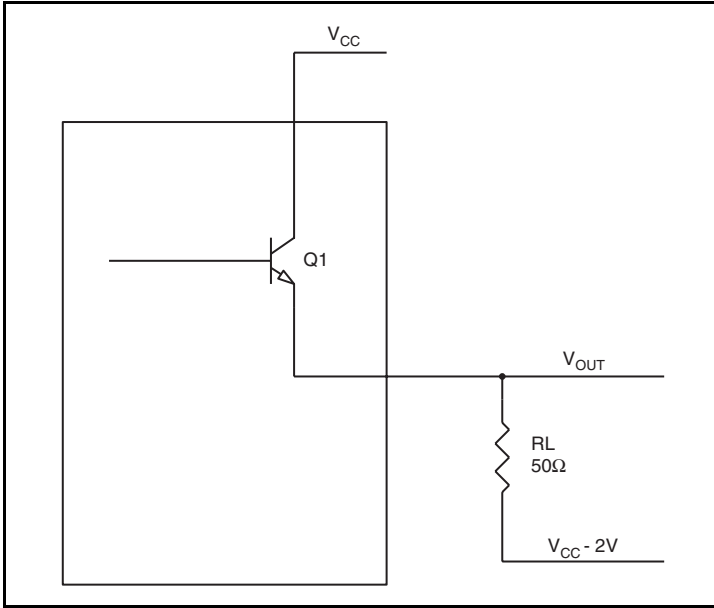

**Figure 7. LVPECL Driver Circuit and Termination**

To calculate worst case power dissipation into the load, use the following equations which assume a 50Ω load, and a termination voltage of  $V_{CC} - 2V$ .

- For logic high,  $V_{OUT} = V_{OH\_MAX} = V_{CC\_MAX} - 0.635V$   
 $(V_{CC\_MAX} - V_{OH\_MAX}) = 0.635V$
- For logic low,  $V_{OUT} = V_{OL\_MAX} = V_{CC\_MAX} - 1.59V$   
 $(V_{CC\_MAX} - V_{OL\_MAX}) = 1.59V$

$Pd\_H$  is power dissipation when the output drives high.

$Pd\_L$  is the power dissipation when the output drives low.

$$Pd\_H = [(V_{OH\_MAX} - (V_{CC\_MAX} - 2V))/R_L] * (V_{CC\_MAX} - V_{OH\_MAX}) = [(2V - (V_{CC\_MAX} - V_{OH\_MAX}))/R_L] * (V_{CC\_MAX} - V_{OH\_MAX}) = [(2V - 0.635V)/50\Omega] * 0.635V = 17.3mW$$

$$Pd\_L = [(V_{OL\_MAX} - (V_{CC\_MAX} - 2V))/R_L] * (V_{CC\_MAX} - V_{OL\_MAX}) = [(2V - (V_{CC\_MAX} - V_{OL\_MAX}))/R_L] * (V_{CC\_MAX} - V_{OL\_MAX}) = [(2V - 1.59V)/50\Omega] * 1.59V = 13mW$$

$$\text{Total Power Dissipation per output pair} = Pd\_H + Pd\_L = 30.3mW$$

## Reliability Information

**Table 7A.  $\theta_{JA}$  vs. Air Flow Table for an 16 Lead SOIC**

$\theta_{JA}$ vs. Air Flow			
Meters per Second	0	1	2.5
Multi-Layer PCB, JEDEC Standard Test Boards	70.2°C/W	64.7°C/W	61.6°C/W

**Table 7B.  $\theta_{JA}$  vs. Air Flow Table for an 16 Lead TSSOP Forced Convection**

$\theta_{JA}$ by Velocity			
Meters per Second	0	1	2.5
Multi-Layer PCB, JEDEC Standard Test Boards	100.0°C/W	94.2°C/W	90.2°C/W

## Transistor Count

The transistor count for ICS8S73034I is: 375

This device is pin and function compatible and a suggested replacement for ICS873034.



## Package Outlines and Package Dimensions

Package Outline - G Suffix for 16 Lead TSSOP

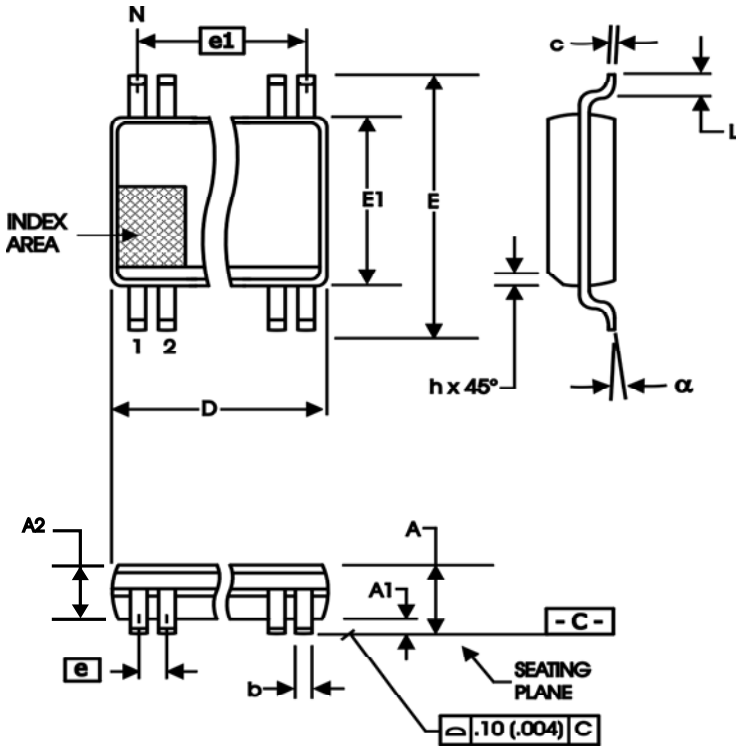

Package Outline - M Suffix for 16 Lead SOIC

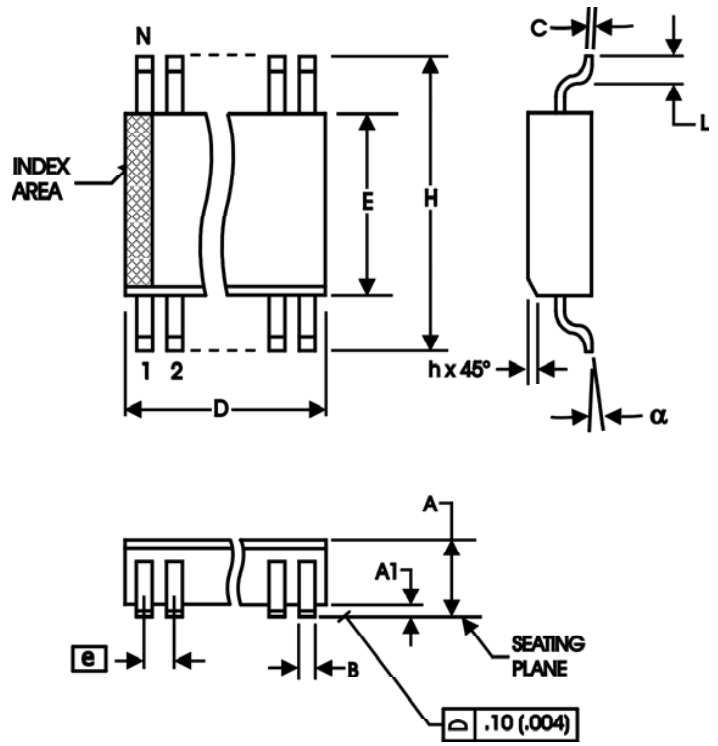

Table 8A. Package Dimensions

All Dimensions in Millimeters		
Symbol	Minimum	Maximum
N	16	
A		1.20
A1	0.05	0.15
A2	0.80	1.05
b	0.19	0.30
c	0.09	0.20
D	4.90	5.10
E	6.40 Basic	
E1	4.30	4.50
e	0.65 Basic	
L	0.45	0.75
α	0°	8°
aaa		0.10

Reference Document: JEDEC Publication 95, MO-153

Table 8B. Package Dimensions

All Dimensions in Millimeters		
Symbol	Minimum	Maximum
N	16	
A	1.35	1.75
A1	0.10	0.25
B	0.33	0.51
C	0.19	0.25
D	9.80	10.00
E	3.80	4.00
e	1.27 Basic	
H	5.80	6.20
h	0.25	0.50
L	0.40	1.27
α	0°	8°

Reference Document: JEDEC Publication 95, MS-012

## Ordering Information

Table 9. Ordering Information

Part/Order Number	Marking	Package	Shipping Packaging	Temperature
8S73034AMILF	8S73034AMIL	"Lead-Free" 16 Lead SOIC	Tube	-40°C to 85°C
8S73034AMILFT	8S73034AMIL	"Lead-Free" 16 Lead SOIC	1000 Tape & Reel	-40°C to 85°C
8S73034AGILF	73034AIL	"Lead-Free" 16 Lead TSSOP	Tube	-40°C to 85°C
8S73034AGILFT	73034AIL	"Lead-Free" 16 Lead TSSOP	2500 Tape & Reel	-40°C to 85°C

NOTE: Parts that are ordered with an "LF" suffix to the part number are the Pb-Free configuration and are RoHS compliant.

## Revision History Sheet

Rev	Table	Page	Description of Change	Date
A	1	2 8 9-10	Pin Description Table - corrected pin 1 as Q0 and pin 2 as nQ0. Updated <i>Wiring the Differential Input to Accept Single-ended Levels</i> section. Updated <i>LVPECL Clock Input Interface</i> sections.	11/8/10
A		1	Features Section - corrected Maximum input frequency bullet, from 2.8MHz to 3.2MHz.	6/8/11



