

### General Description

The IDT8P34S1208I is a high-performance differential LVDS fanout buffer. The device is designed for the fanout of high-frequency, very low additive phase-noise clock and data signals. The IDT8P34S1208I is characterized to operate from a 1.8V power supply. Guaranteed output-to-output and part-to-part skew characteristics make the IDT8P34S1208I ideal for those clock distribution applications demanding well-defined performance and repeatability. Two selectable differential inputs and eight low skew outputs are available. The integrated bias voltage reference enables easy interfacing of single-ended signals to the device inputs. The device is optimized for low power consumption and low additive phase noise.

### Features

- Eight low skew, low additive jitter LVDS output pairs
- Two selectable, differential clock input pairs
- Differential CLK, nCLK pairs can accept the following differential input levels: LVDS, CML
- Maximum input clock frequency: 1.2GHz (maximum)
- LVCMOS/LVTTL interface levels for the control input select pin
- Output skew: 20ps (typical)
- Propagation delay: 315ps (typical)
- Low additive phase jitter, RMS;  $f_{REF} = 156.25\text{MHz}$ ,  $V_{PP} = 1\text{V}$ , 12kHz - 20MHz: 41fs (typical)
- Full 1.8V supply voltage
- Lead-free (RoHS 6), 28-Lead VFQFN packaging
- -40°C to 85°C ambient operating temperature

### Block Diagram.

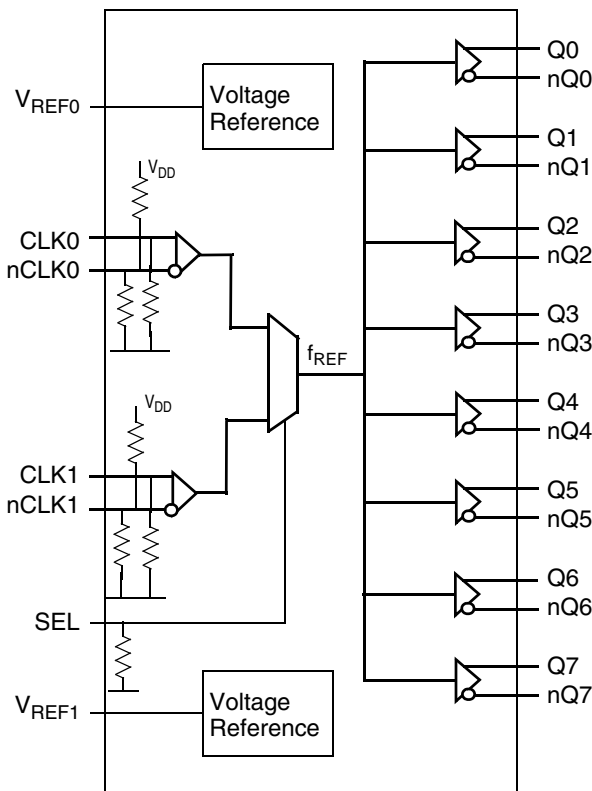

### Pin Assignment

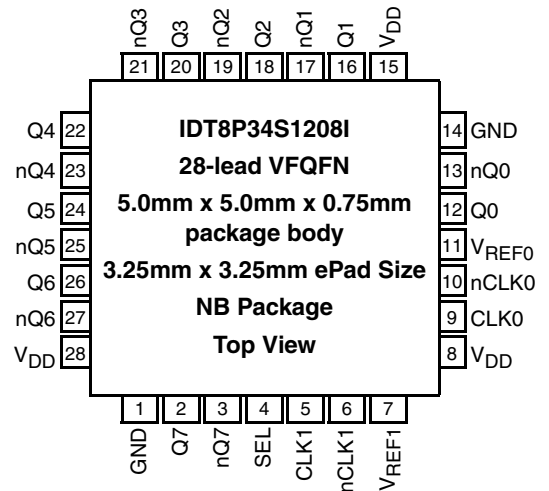

## Pin Description and Pin Characteristic Tables

**Table 1. Pin Descriptions**<sup>Note 1.</sup>

Number	Name	Type		Description
1, 14	GND	Power		Power supply pin.
2, 3	Q7, nQ7	Output		Differential output pair 7. LVDS interface levels.
4	SEL	Input	Pulldown	Reference select control pin. See Table 3 for function. LVCMOS/LVTTL interface levels.
5	CLK1	Input	Pulldown	Non-inverting differential clock/data input 1.
6	nCLK1	Input	Pullup/ Pulldown	Inverting differential clock/data input 1. $V_{DD}/2$ default when left floating.
7	$V_{REF1}$	Output		Bias voltage reference. Provides an input bias voltage for the CLK1, nCLK1 input pair in AC-coupled applications. Refer to <i>Figures 2B and 2C</i> for applicable AC-coupled input interfaces.
8, 15, 28	$V_{DD}$	Power		Power supply pin.
9	CLK0	Input	Pulldown	Non-inverting differential clock/data input 0.
10	nCLK0	Input	Pullup/ Pulldown	Inverting differential clock/data input 0. $V_{DD}/2$ default when left floating.
11	$V_{REF0}$	Output		Bias voltage reference. Provides an input bias voltage for the CLK0, nCLK0 input pair in AC-coupled applications. Refer to <i>Figures 2B and 2C</i> for applicable AC-coupled input interfaces.
12, 13	Q0, nQ0	Output		Differential output pair 0. LVDS interface levels.
16, 17	Q1, nQ1	Output		Differential output pair 1. LVDS interface levels.
18, 19	Q2, nQ2	Output		Differential output pair 2. LVDS interface levels.
20, 21	Q3, nQ3	Output		Differential output pair 3. LVDS interface levels.
22, 23	Q4, nQ4	Output		Differential output pair 4. LVDS interface levels.
24, 25	Q5, nQ5	Output		Differential output pair 5. LVDS interface levels.
26, 27	Q6, nQ6	Output		Differential output pair 6. LVDS interface levels.

1. *Pulldown* and *Pullup* refers to an internal input resistors. See Table 2, *Pin Characteristics*, for typical values.

**Table 2. Pin Characteristics**

Symbol	Parameter	Test Conditions	Minimum	Typical	Maximum	Units
$C_{IN}$	Input Capacitance			2		pF
$R_{PULLDOWN}$	Input Pulldown Resistor			51		k $\Omega$
$R_{PULLUP}$	Input Pullup Resistor			51		k $\Omega$

**Table 3. SEL Input Function Table**<sup>Note 1.</sup>

Input	Operation
SEL	
0	CLK0, nCLK0 is the selected differential clock input.
1	CLK1, nCLK1 is the selected differential clock input.

1. SEL is an asynchronous control.

## Absolute Maximum Ratings

NOTE: Stresses beyond those listed under *Absolute Maximum Ratings* may cause permanent damage to the device. These ratings are stress specifications only. Functional operation of product at these conditions or any conditions beyond those listed in the *DC Characteristics* or *AC Characteristics* is not implied. Exposure to absolute maximum rating conditions for extended periods may affect product reliability.

Item	Rating
Supply Voltage, $V_{DD}$	4.6V
Inputs, $V_I$	-0.5V to $V_{DD} + 0.5V$
Outputs, $I_O$ Continuous Current Surge Current	10mA 15mA
Input Sink/Source, $I_{REF}$	$\pm 2mA$
Maximum Junction Temperature, $T_{J,MAX}$	125°C
Storage Temperature, $T_{STG}$	-65°C to 150°C
ESD - Human Body Model, NOTE 1	2000V
ESD - Charged Device Model, NOTE 1	1500V

NOTE 1: According to JEDEC JS-001-2012/JESD22-C101E.

## DC Electrical Characteristics

**Table 4A. Power Supply DC Characteristics,  $V_{DD} = 1.8V \pm 5\%$ ,  $T_A = -40^\circ C$  to  $85^\circ C$**

Symbol	Parameter	Test Conditions	Minimum	Typical	Maximum	Units
$V_{DD}$	Power Supply Voltage		1.71	1.8	1.89	V
$I_{DD}$	Power Supply Current	Q0 to Q7 terminated 100 $\Omega$ between nQx, Qx		120	140	mA

**Table 4B. LVCMOS/LVTTL DC Characteristics,  $V_{DD} = 1.8V \pm 5\%$ ,  $T_A = -40^\circ C$  to  $85^\circ C$**

Symbol	Parameter	Test Conditions	Minimum	Typical	Maximum	Units
$V_{IH}$	Input High Voltage		$V_{DD} * 0.65$		$V_{DD} + 0.3$	V
$V_{IL}$	Input Low Voltage		-0.3		$V_{DD} * 0.35$	V
$I_{IH}$	Input High Current	SEL $V_{DD} = V_{IN} = 1.89V$			150	$\mu A$
$I_{IL}$	Input Low Current	SEL $V_{DD} = 1.89V, V_{IN} = 0V$	-10			$\mu A$

**Table 4C. Differential Inputs Characteristics,  $V_{DD} = 1.8V \pm 5\%$ ,  $T_A = -40^{\circ}C$  to  $85^{\circ}C$** 

Symbol	Parameter	Test Conditions	Minimum	Typical	Maximum	Units
$I_{IH}$	Input High Current	CLK0, nCLK0, CLK1, nCLK1	$V_{IN} = V_{DD} = 1.89V$		150	$\mu A$
$I_{IL}$	Input Low Current	CLK0, CLK1	$V_{IN} = 0V, V_{DD} = 1.89V$	-10		$\mu A$
		nCLK0, nCLK1	$V_{IN} = 0V, V_{DD} = 1.89V$	-150		$\mu A$
$V_{REF}$	Reference Voltage for Input Bias <sup>Note 1.</sup>	$I_{REF} = +100\mu A, V_{DD} = 1.8V$	0.9		1.30	V
$V_{PP}$	Peak-to-Peak Voltage <sup>Note3.</sup>	$V_{DD} = 1.89V$	0.2		1.0	V
$V_{CMR}$	Common Mode Input Voltage <sup>Note 2. Note 3.</sup>		0.9		$V_{DD} - (V_{PP}/2)$	V

- $V_{REF}$  specification is applicable to the AC-coupled input interfaces shown in *Figures 2B and 2C*.
- Common mode input voltage is defined as crosspoint voltage.
- $V_{IL}$  should not be less than -0.3V and  $V_{IH}$  should not be higher than  $V_{DD}$ .

**Table 4D. LVDS DC Characteristics,  $V_{DD} = 1.8V \pm 5\%$ ,  $T_A = -40^{\circ}C$  to  $85^{\circ}C$** 

Symbol	Parameter	Test Conditions	Minimum	Typical	Maximum	Units
$V_{OD}$	Differential Output Voltage	outputs loaded with $100\ \Omega$	247	350	454	mV
$\Delta V_{OD}$	$V_{OD}$ Magnitude Change				50	mV
$V_{OS}$	Offset Voltage		1.0	1.23	1.4	V
$\Delta V_{OS}$	$V_{OS}$ Magnitude Change				50	mV

## AC Electrical Characteristics

**Table 5. AC Electrical Characteristics,  $V_{DD} = 1.8V \pm 5\%$ ,  $T_A = -40^\circ C$  to  $85^\circ$  Note 1.**

Symbol	Parameter		Test Conditions	Minimum	Typical	Maximum	Units
$f_{REF}$	Input Frequency	CLK[0:1], nCLK[0:1]				1.2	GHz
$\Delta V/\Delta t$	Input Edge Rate	CLK[0:1], nCLK[0:1]		1.5			V/ns
$t_{PD}$	Propagation Delay <sup>Note 2.</sup>		CLK[0:1]; nCLK[0:1] to any Qx, nQx for $V_{PP} = 0.4V$	190	315	400	ps
$t_{sk(o)}$	Output Skew <sup>Note 3. Note 4.</sup>				20	40	ps
$t_{sk(i)}$	Input Skew				10	45	ps
$t_{sk(p)}$	Pulse Skew		$f_{REF} = 100MHz$		6	20	ps
$t_{sk(pp)}$	Part-to-Part Skew <sup>Note 5.</sup>					250	ps
$t_{JIT}$	Buffer Additive Phase Jitter, RMS; refer to Additive Phase Jitter Section		$f_{REF} = 122.88MHz$ Square Wave, $V_{PP} = 1V$ , Integration Range: 1kHz – 40MHz		122	221	fs
			$f_{REF} = 122.88MHz$ Square Wave, $V_{PP} = 1V$ , Integration Range: 10kHz – 20MHz		88	110	fs
			$f_{REF} = 122.88MHz$ Square Wave, $V_{PP} = 1V$ , Integration Range: 12kHz – 20MHz		84	110	fs
			$f_{REF} = 156.25MHz$ Square Wave, $V_{PP} = 1V$ , Integration Range: 1kHz – 40MHz		57	107	fs
			$f_{REF} = 156.25MHz$ Square Wave, $V_{PP} = 1V$ , Integration Range: 10kHz – 20MHz		41	78	fs
			$f_{REF} = 156.25MHz$ Square Wave, $V_{PP} = 1V$ , Integration Range: 12kHz – 20MHz		41	78	fs
			$f_{REF} = 156.25MHz$ Square Wave, $V_{PP} = 0.5V$ , Integration Range: 1kHz – 40MHz		55	112	fs
			$f_{REF} = 156.25MHz$ Square Wave, $V_{PP} = 0.5V$ , Integration Range: 10kHz – 20MHz		40	85	fs
			$f_{REF} = 156.25MHz$ Square Wave, $V_{PP} = 0.5V$ , Integration Range: 12kHz – 20MHz		40	85	fs
$t_R / t_F$	Output Rise/ Fall Time		10% to 90% outputs loaded with 100 $\Omega$		305	400	ps
			20% to 80% outputs loaded with 100 $\Omega$		175	260	ps
$MUX_{ISOLATION}$	Mux Isolation <sup>Note 6.</sup>		$f_{REF} = 100MHz$		80		dB

- Electrical parameters are guaranteed over the specified ambient operating temperature range, which is established when the device is mounted in a test socket with maintained transverse airflow greater than 500 lpm. The device will meet specifications after thermal equilibrium has been reached under these conditions.
- Measured from the differential input crossing point to the differential output crossing point
- Defined as skew between outputs at the same supply voltage and with equal load conditions. Measured at the differential cross points.
- This parameter is defined in accordance with JEDEC Standard 65.
- Defined as skew between outputs on different devices operating at the same supply voltage, same frequency, same temperature and with equal load conditions. Using the same type of inputs on each device, the outputs are measured at the differential cross points.
- Qx, nQx outputs measured differentially. See *MUX Isolation diagram* in the *Parameter Measurement Information section*.

## Additive Phase Jitter

The spectral purity in a band at a specific offset from the fundamental compared to the power of the fundamental is called the **dBc Phase Noise**. This value is normally expressed using a Phase noise plot and is most often the specified plot in many applications. Phase noise is defined as the ratio of the noise power present in a 1Hz band at a specified offset from the fundamental frequency to the power value of the fundamental. This ratio is expressed in decibels (dBm) or a ratio

of the power in the 1Hz band to the power in the fundamental. When the required offset is specified, the phase noise is called a **dBc** value, which simply means dBm at a specified offset from the fundamental. By investigating jitter in the frequency domain, we get a better understanding of its effects on the desired application over the entire time record of the signal. It is mathematically possible to calculate an expected bit error rate given a phase noise plot.

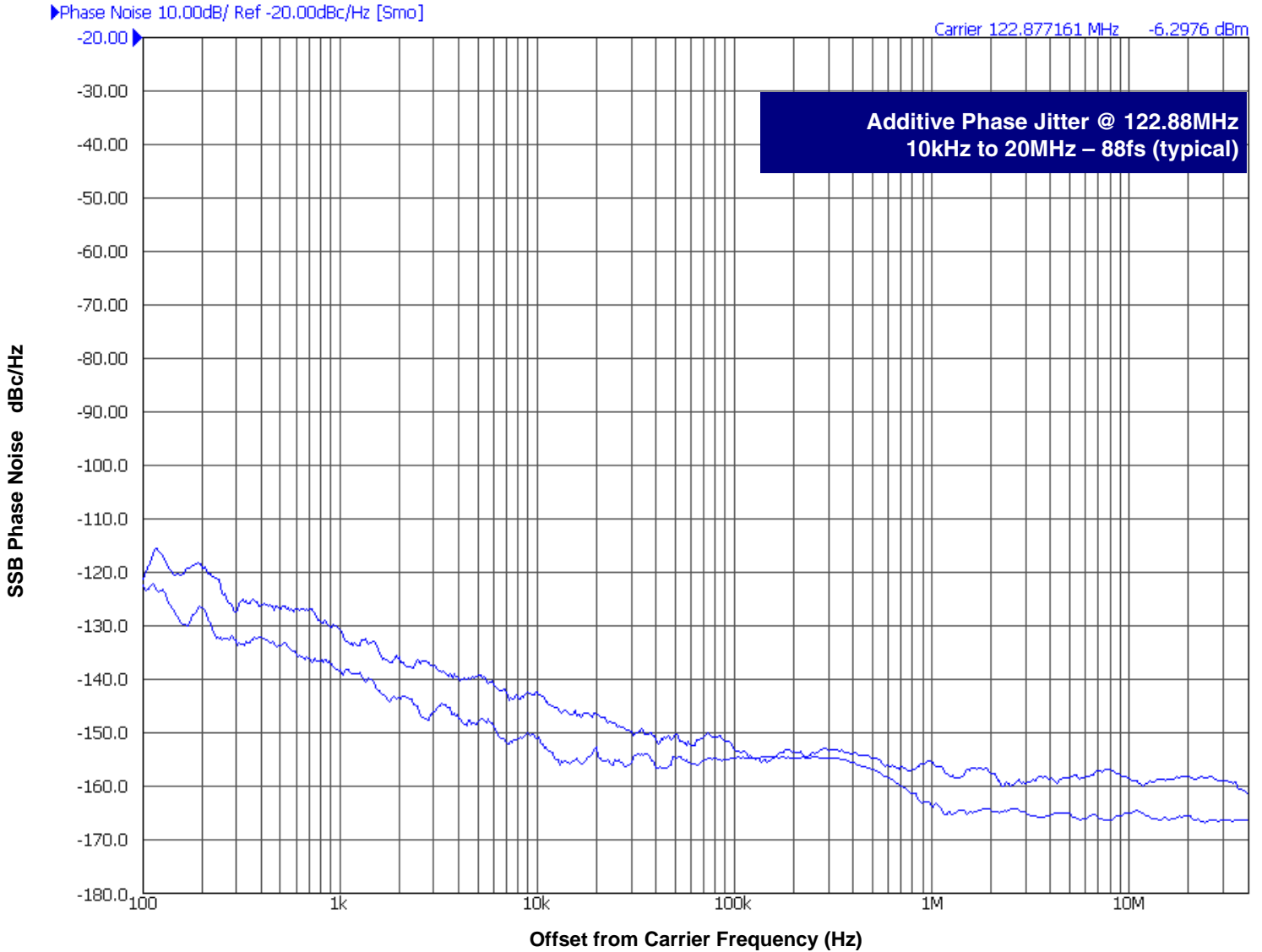

As with most timing specifications, phase noise measurements have issues relating to the limitations of the measurement equipment. The noise floor of the equipment can be higher or lower than the noise floor of the device. Additive phase noise is dependent on both the noise floor of the input source and measurement equipment.

Measured using a Rohde & Schwarz SMA 100 A Signal Generator as the input source.

## Additive Phase Jitter

The spectral purity in a band at a specific offset from the fundamental compared to the power of the fundamental is called the **dBc Phase Noise**. This value is normally expressed using a Phase noise plot and is most often the specified plot in many applications. Phase noise is defined as the ratio of the noise power present in a 1Hz band at a specified offset from the fundamental frequency to the power value of the fundamental. This ratio is expressed in decibels (dBm) or a ratio

of the power in the 1Hz band to the power in the fundamental. When the required offset is specified, the phase noise is called a **dBc** value, which simply means dBm at a specified offset from the fundamental. By investigating jitter in the frequency domain, we get a better understanding of its effects on the desired application over the entire time record of the signal. It is mathematically possible to calculate an expected bit error rate given a phase noise plot.

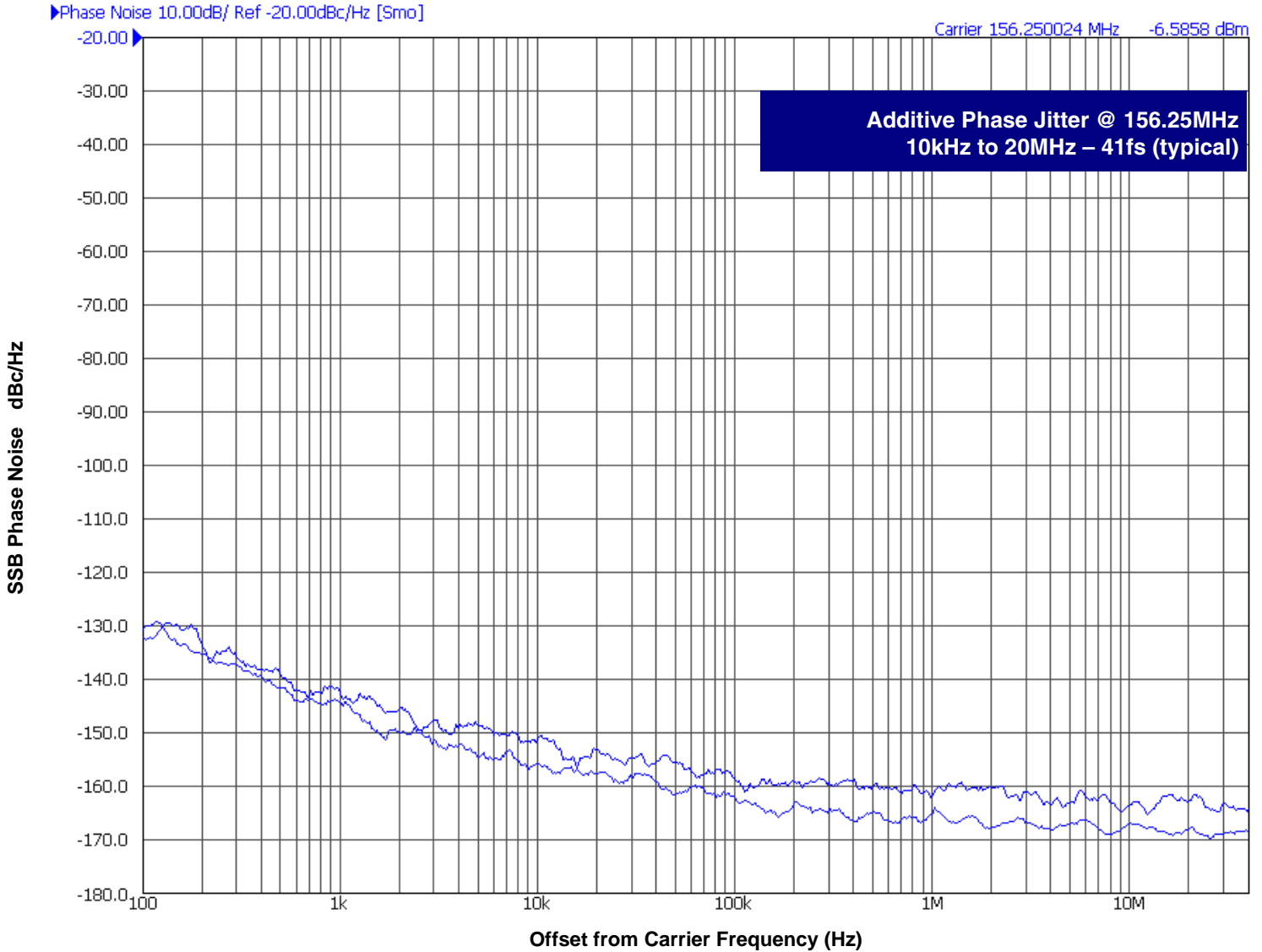

As with most timing specifications, phase noise measurements have issues relating to the limitations of the measurement equipment. The noise floor of the equipment can be higher or lower than the noise floor of the device. Additive phase noise is dependent on both the noise floor of the input source and measurement equipment.

Measured using a Wenzel 156.25MHz Oscillator as the input source.

## Parameter Measurement Information

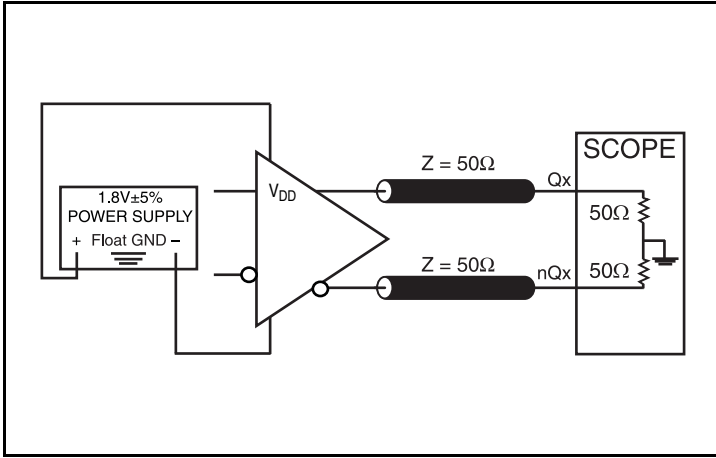

1.8V LVDS Output Load Test Circuit

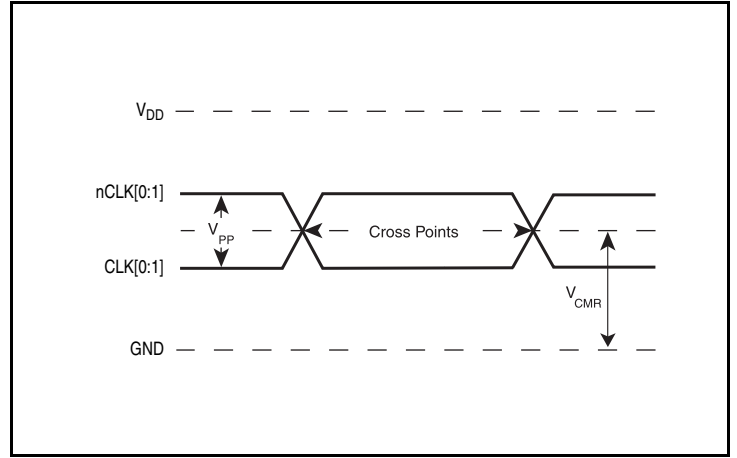

Differential Input Level

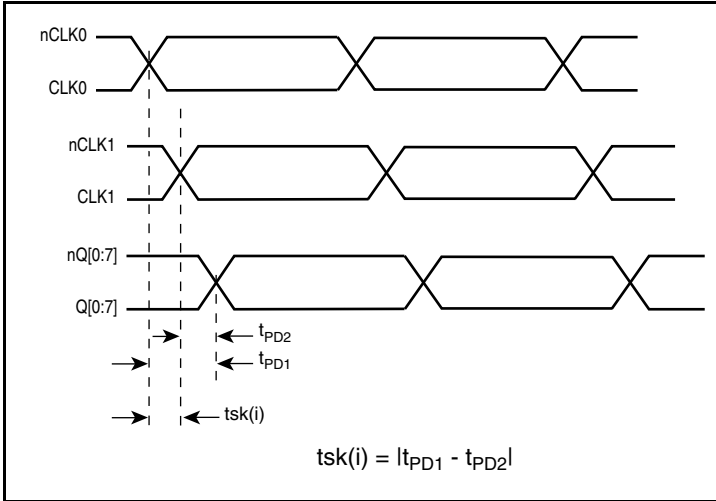

Input Skew

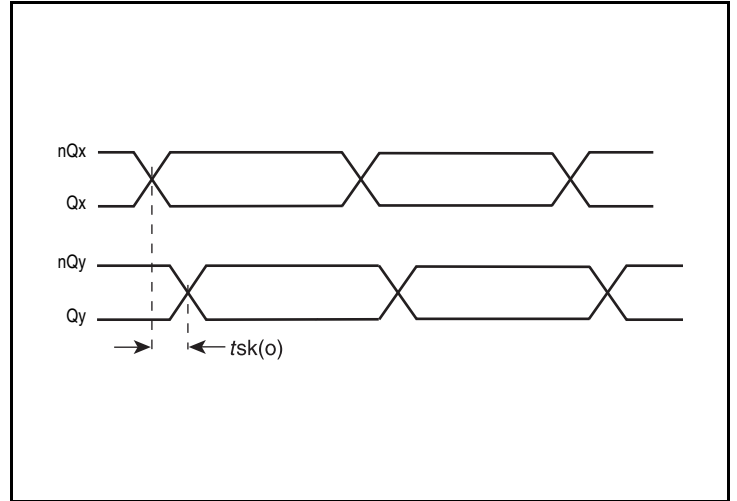

Output Skew

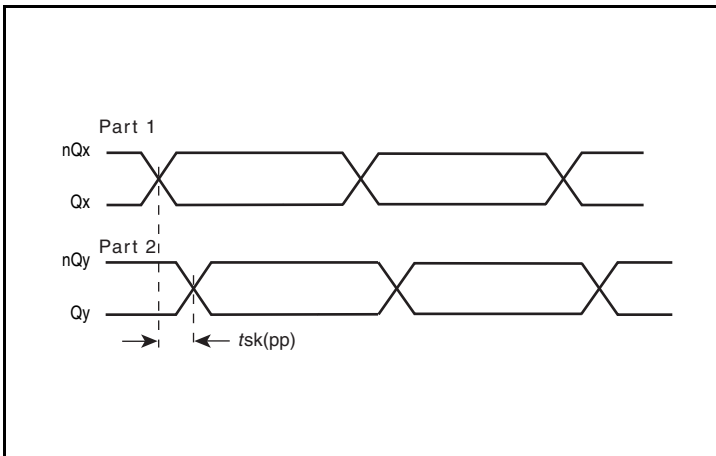

Part-to-Part Skew

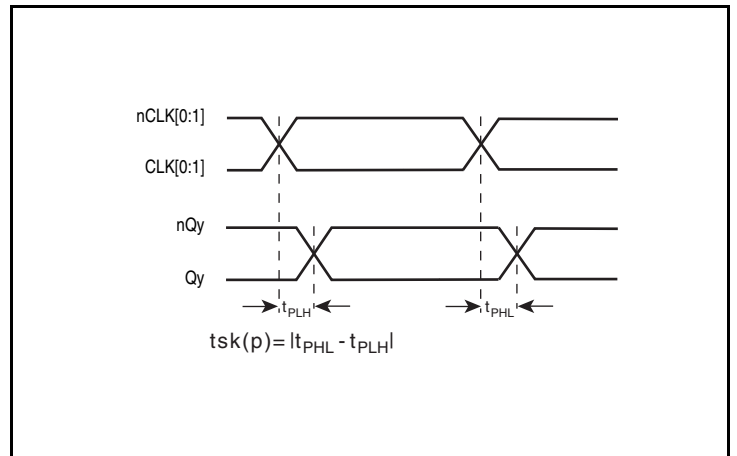

Pulse Skew



## Parameter Measurement Information, continued

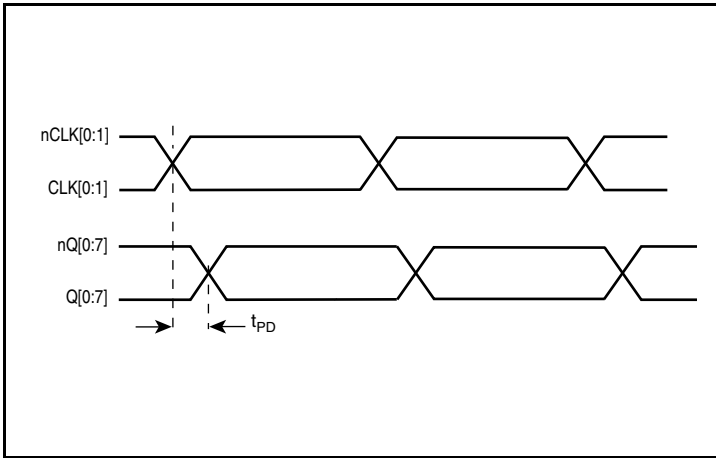

**Propagation Delay**

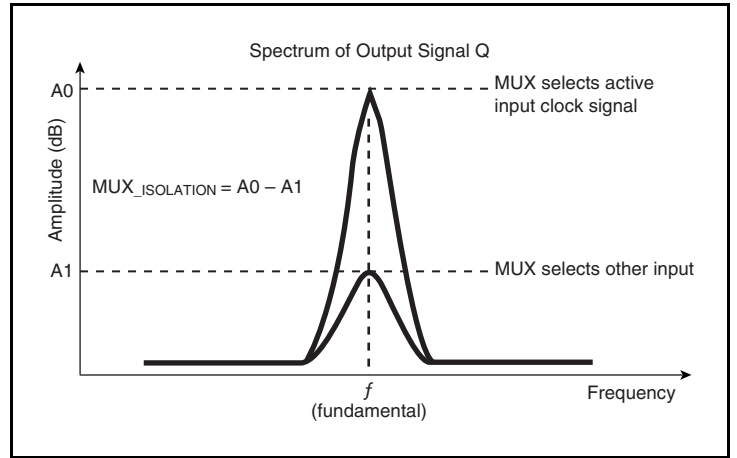

**MUX Isolation**

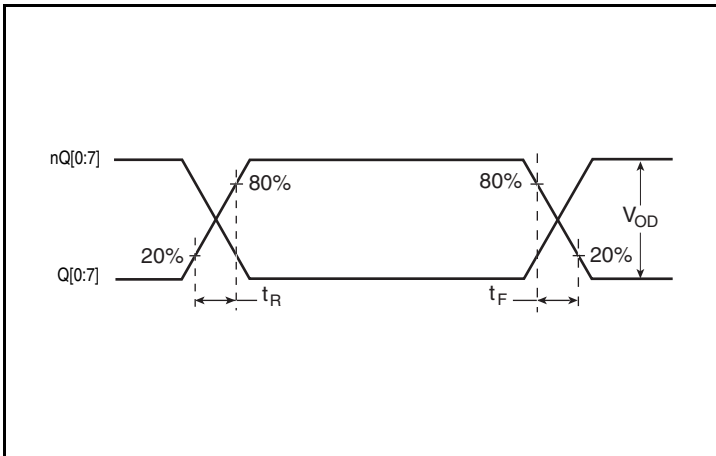

**Output Rise/Fall Time**

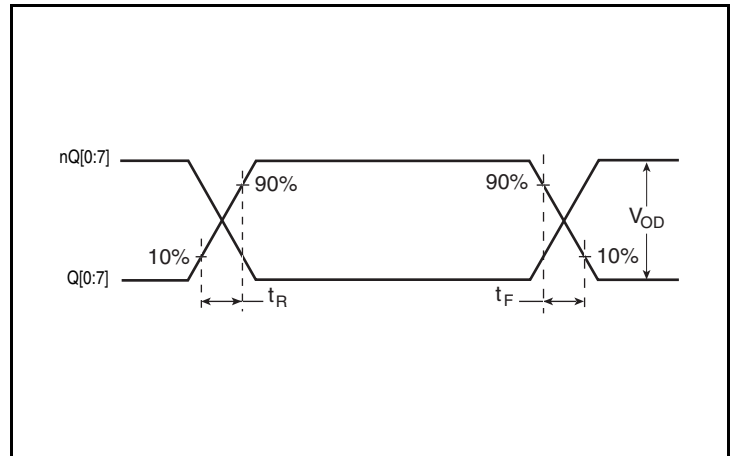

**Output Rise/Fall Time**

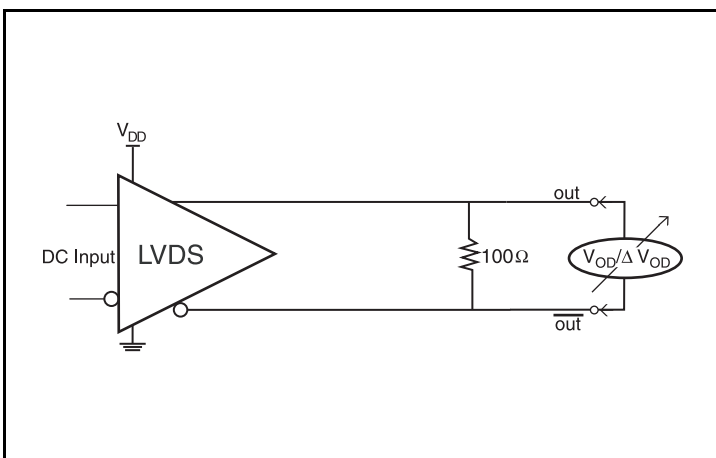

**Differential Output Voltage Setup**

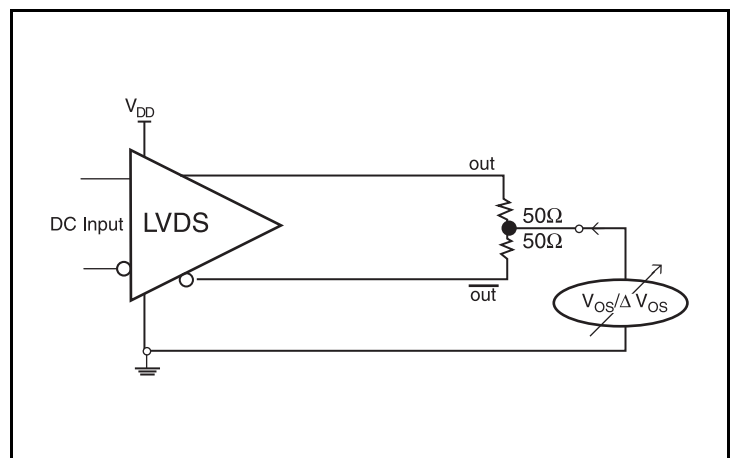

**Offset Voltage Setup**

## Applications Information

### Wiring the Differential Input to Accept Single-Ended Levels

Figure 1 shows how a differential input can be wired to accept single ended levels. The reference voltage  $V_1 = V_{DD}/2$  is generated by the bias resistors R1 and R2. The bypass capacitor (C1) is used to help filter noise on the DC bias. This bias circuit should be located as close to the input pin as possible. The ratio of R1 and R2 might need to be adjusted to position the  $V_1$  in the center of the input voltage swing. For example, if the input clock swing is 2.5V and  $V_{DD} = 3.3V$ , R1 and R2 value should be adjusted to set  $V_1$  at 1.25V. The values below are for when both the single ended swing and  $V_{DD}$  are at the same voltage. This configuration requires that the sum of the output impedance of the driver ( $R_o$ ) and the series resistance ( $R_s$ ) equals the transmission line impedance. In addition, matched termination at the input will attenuate the signal in half. This can be done in one of two ways. First, R3 and R4 in parallel should equal the transmission line

impedance. For most 50Ω applications, R3 and R4 can be 100Ω. The values of the resistors can be increased to reduce the loading for slower and weaker LVCMOS driver. When using single-ended signaling, the noise rejection benefits of differential signaling are reduced. Even though the differential input can handle full rail LVCMOS signaling, it is recommended that the amplitude be reduced. The datasheet specifies a lower differential amplitude, however this only applies to differential signals. For single-ended applications, the swing can be larger, however  $V_{IL}$  cannot be less than -0.3V and  $V_{IH}$  cannot be more than  $V_{DD} + 0.3V$ . Though some of the recommended components might not be used, the pads should be placed in the layout. They can be utilized for debugging purposes. The datasheet specifications are characterized and guaranteed by using a differential signal.

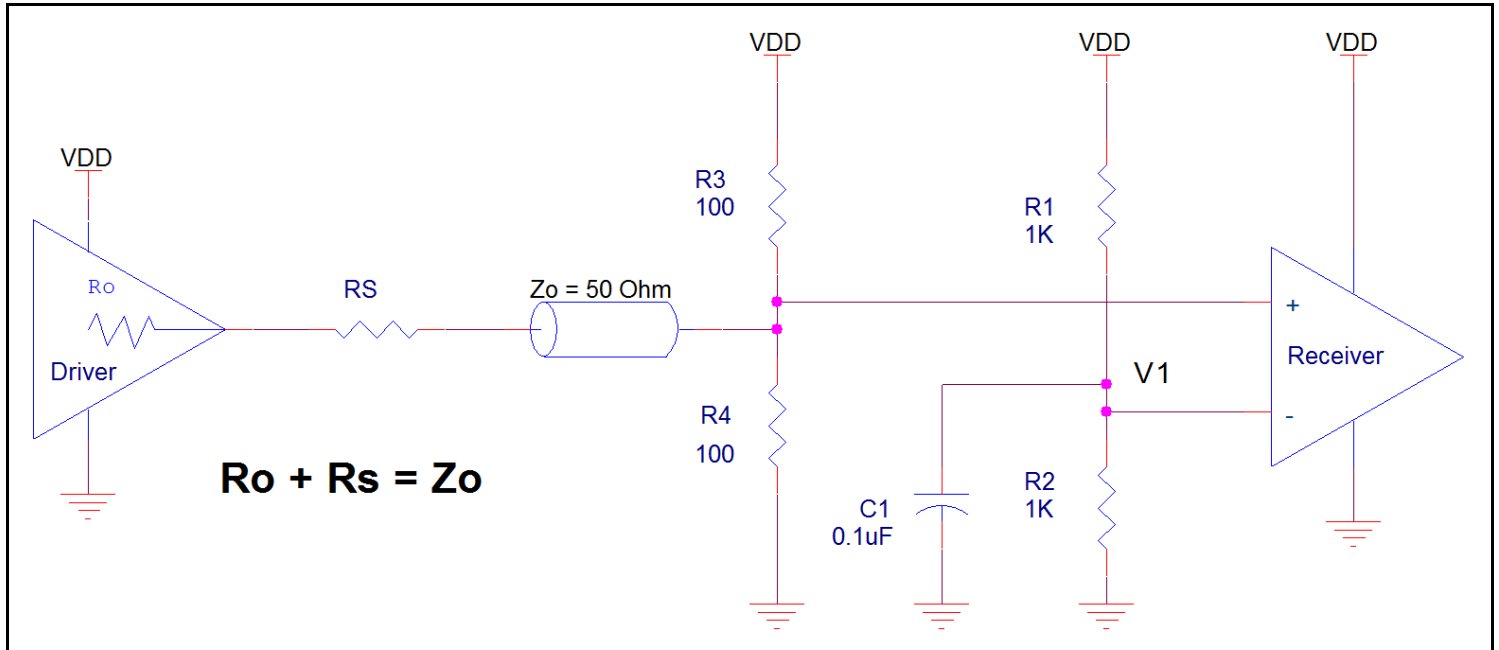

Figure 1. Recommended Schematic for Wiring a Differential Input to Accept Single-ended Levels

### Recommendations for Unused Input and Output Pins

#### Inputs:

##### CLK/nCLK Inputs

For applications not requiring the use of a differential input, both the CLK and nCLK can be left floating. Though not required, but for additional protection, a 1kΩ resistor can be tied from CLK to ground.

#### Outputs:

##### LVDS Outputs

Unused LVDS outputs must either have a 100Ω differential termination or have a 100Ω pullup resistor to  $V_{DD}$  in order to ensure proper device operation.

## 1.8V Differential Clock Input Interface

The CLK /nCLK accepts LVDS and other differential signals. The differential input signal must meet both the  $V_{PP}$  and  $V_{CMR}$  input requirements. Figures 2A to 2D show interface examples for the CLK /nCLK input driven by the most common driver types. The input

interfaces suggested here are examples only. If the driver is from another vendor, use their termination recommendation. Please consult with the vendor of the driver component to confirm the driver termination requirements.

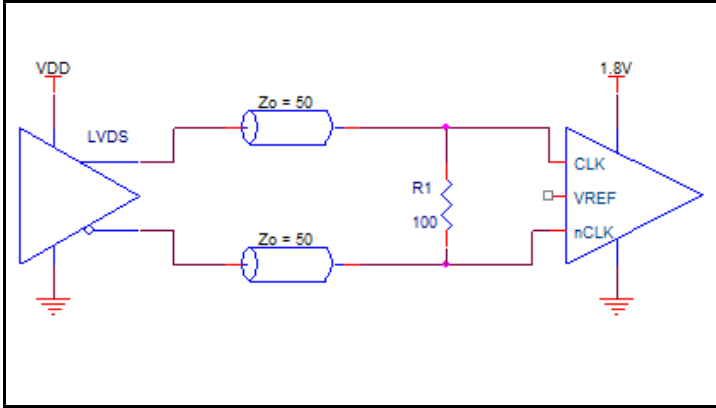

Figure 2A. Differential Input Driven by an LVDS Driver - DC Coupling

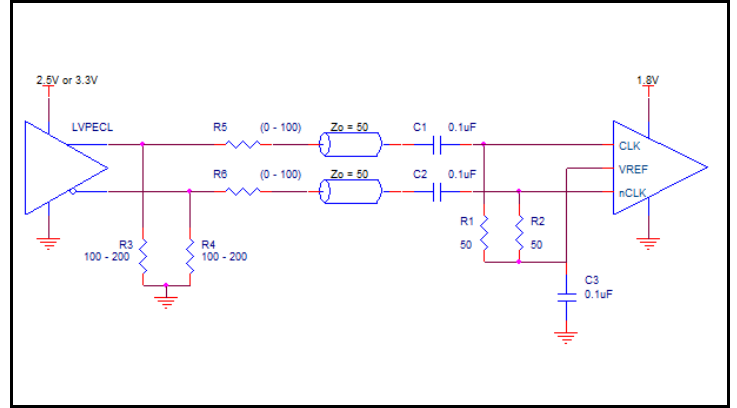

Figure 2B. Differential Input Driven by an LVPECL Driver - AC Coupling

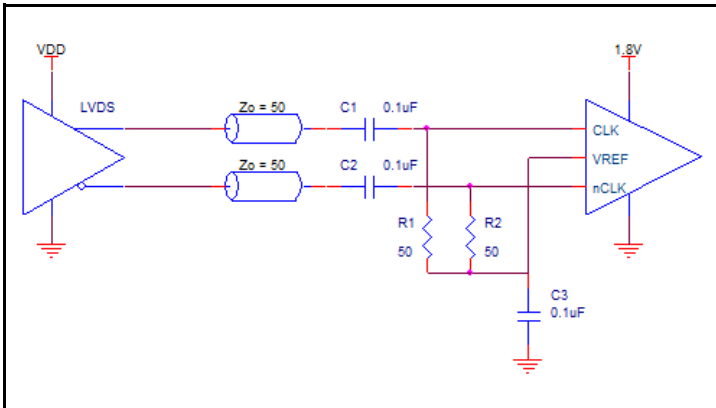

Figure 2C. Differential Input Driven by an LVDS Driver - AC Coupling

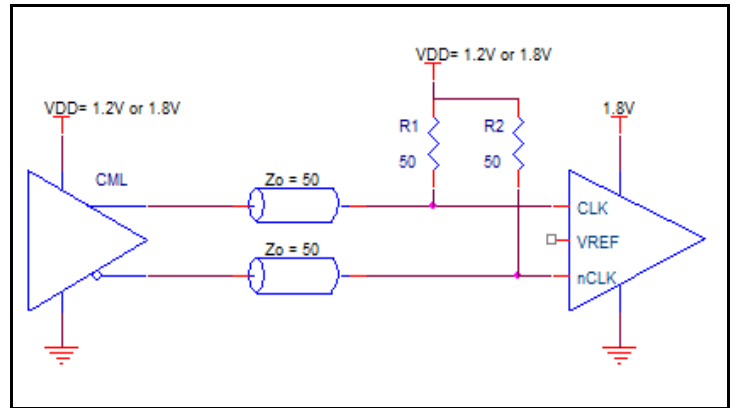
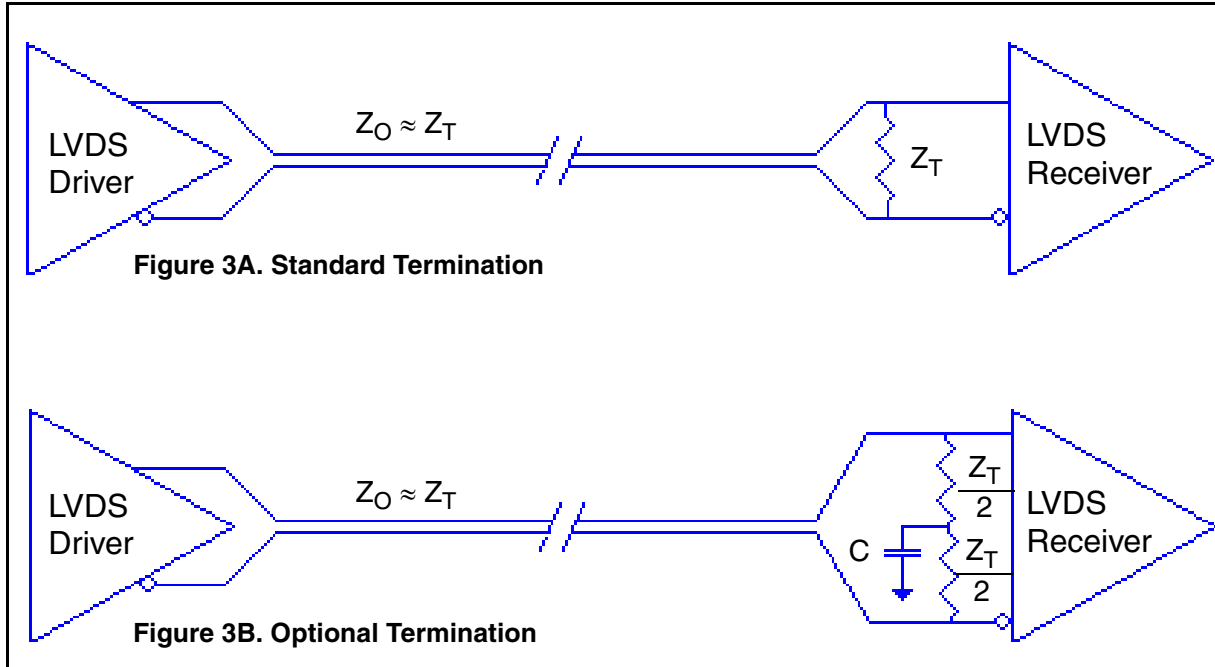

Figure 2D. Differential Input Driven by a CML Driver

## LVDS Driver Termination

For a general LVDS interface, the recommended value for the termination impedance ( $Z_T$ ) is between  $90\Omega$  and  $132\Omega$ . The actual value should be selected to match the differential impedance ( $Z_0$ ) of your transmission line. A typical point-to-point LVDS design uses a  $100\Omega$  parallel resistor at the receiver and a  $100\Omega$  differential transmission-line environment. In order to avoid any transmission-line reflection issues, the components should be surface mounted and must be placed as close to the receiver as possible. IDT offers a full line of LVDS compliant devices with two types of output structures: current source and voltage source type. The

standard termination schematic as shown in *Figure 3A* can be used with either type of output structure. *Figure 3B*, which can also be used with both output types, is an optional termination with center tap capacitance to help filter common mode noise. The capacitor value should be approximately  $50\text{pF}$ . If using a non-standard termination, it is recommended to contact IDT and confirm if the output structure is current source or voltage source type. In addition, since these outputs are LVDS compatible, the input receiver's amplitude and common-mode input range should be verified for compatibility with the output.



### LVDS Termination

## VFQFN EPAD Thermal Release Path

In order to maximize both the removal of heat from the package and the electrical performance, a land pattern must be incorporated on the Printed Circuit Board (PCB) within the footprint of the package corresponding to the exposed metal pad or exposed heat slug on the package, as shown in *Figure 4*. The solderable area on the PCB, as defined by the solder mask, should be at least the same size/shape as the exposed pad/slug area on the package to maximize the thermal/electrical performance. Sufficient clearance should be designed on the PCB between the outer edges of the land pattern and the inner edges of pad pattern for the leads to avoid any shorts.

While the land pattern on the PCB provides a means of heat transfer and electrical grounding from the package to the board through a solder joint, thermal vias are necessary to effectively conduct from the surface of the PCB to the ground plane(s). The land pattern must be connected to ground through these vias. The vias act as “heat pipes”. The number of vias (i.e. “heat pipes”) are application specific

and dependent upon the package power dissipation as well as electrical conductivity requirements. Thus, thermal and electrical analysis and/or testing are recommended to determine the minimum number needed. Maximum thermal and electrical performance is achieved when an array of vias is incorporated in the land pattern. It is recommended to use as many vias connected to ground as possible. It is also recommended that the via diameter should be 12 to 13mils (0.30 to 0.33mm) with 1oz copper via barrel plating. This is desirable to avoid any solder wicking inside the via during the soldering process which may result in voids in solder between the exposed pad/slug and the thermal land. Precautions should be taken to eliminate any solder voids between the exposed heat slug and the land pattern. Note: These recommendations are to be used as a guideline only. For further information, please refer to the Application Note on the Surface Mount Assembly of Amkor’s Thermally/Electrically Enhance Leadframe Base Package, Amkor Technology.

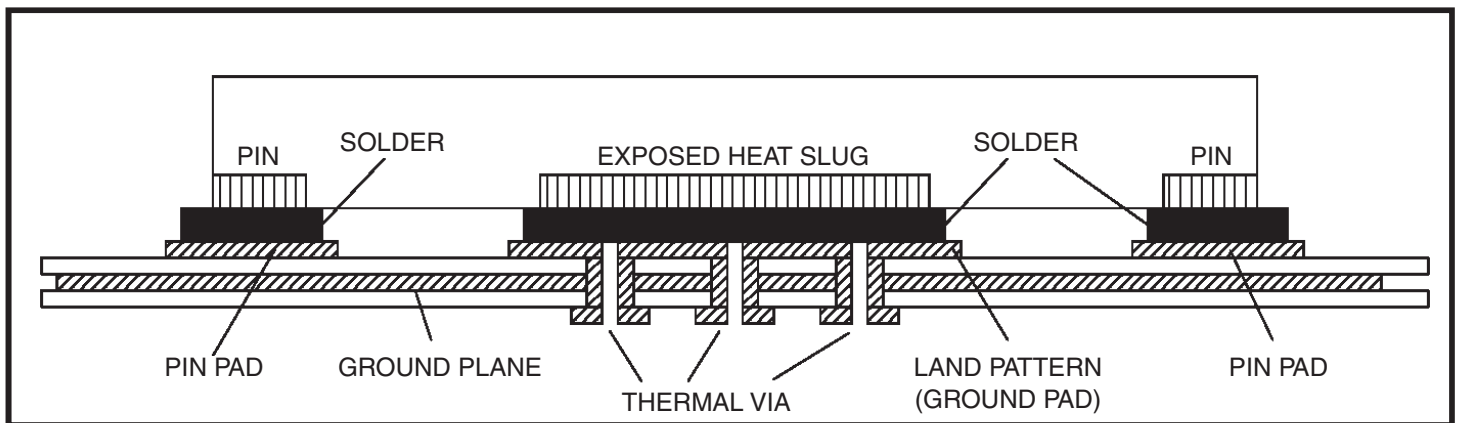

**Figure 4. P.C. Assembly for Exposed Pad Thermal Release Path – Side View (drawing not to scale)**

## Power Considerations

This section provides information on power dissipation and junction temperature for the IDT8P34S1208I. Equations and example calculations are also provided.

### 1. Power Dissipation.

The total power dissipation for the IDT8P34S1208I is the sum of the core power plus the output power dissipation due to the load. The following is the power dissipation for  $V_{DD} = 1.8V + 5\% = 1.89V$ , which gives worst case results.

The maximum current at 85°C is as follows:

$$I_{DD\_MAX} = 126mA$$

- $Power_{(core)MAX} = V_{DD\_MAX} * I_{DD\_MAX} = 1.89V * 126mA = \mathbf{238.14mW}$

$$\mathbf{Total Power_{MAX} = 238.14mW}$$

### 2. Junction Temperature.

Junction temperature,  $T_j$ , is the temperature at the junction of the bond wire and bond pad directly affects the reliability of the device. The maximum recommended junction temperature is 125°C. Limiting the internal transistor junction temperature,  $T_j$ , to 125°C ensures that the bond wire and bond pad temperature remains below 125°C.

The equation for  $T_j$  is as follows:  $T_j = \theta_{JA} * Pd\_total + T_A$

$T_j$  = Junction Temperature

$\theta_{JA}$  = Junction-to-Ambient Thermal Resistance

$Pd\_total$  = Total Device Power Dissipation (example calculation is in section 1 above)

$T_A$  = Ambient Temperature

In order to calculate junction temperature, the appropriate junction-to-ambient thermal resistance  $\theta_{JA}$  must be used. Assuming no air flow and a multi-layer board, the appropriate value is 46.2°C/W per Table 6 below.

Therefore,  $T_j$  for an ambient temperature of 85°C with all outputs switching is:

$$85^\circ C + 0.238W * 46.2^\circ C/W = 96^\circ C. \text{ This is below the limit of } 125^\circ C.$$

This calculation is only an example.  $T_j$  will obviously vary depending on the number of loaded outputs, supply voltage, air flow and the type of board (multi-layer).

**Table 6. Thermal Resistance  $\theta_{JA}$  for 28 Lead VFQFN**

$\theta_{JA}$ at 0 Air Flow			
Meters per Second	0	1	2
Multi-Layer PCB, JEDEC Standard Test Boards	46.2°C/W	39.4C/W	37.1°C/W

## Reliability Information

**Table 7.  $\theta_{JA}$  vs. Air Flow Table for a 28 Lead VFQFN**

$\theta_{JA}$ at 0 Air Flow			
Meters per Second	0	1	2
Multi-Layer PCB, JEDEC Standard Test Boards	46.2°C/W	39.4C/W	37.1°C/W

## Transistor Count

The transistor count for the IDT8P34S1208I is: 976

# 28 Lead VFQFN Package Outline and Package Dimensions

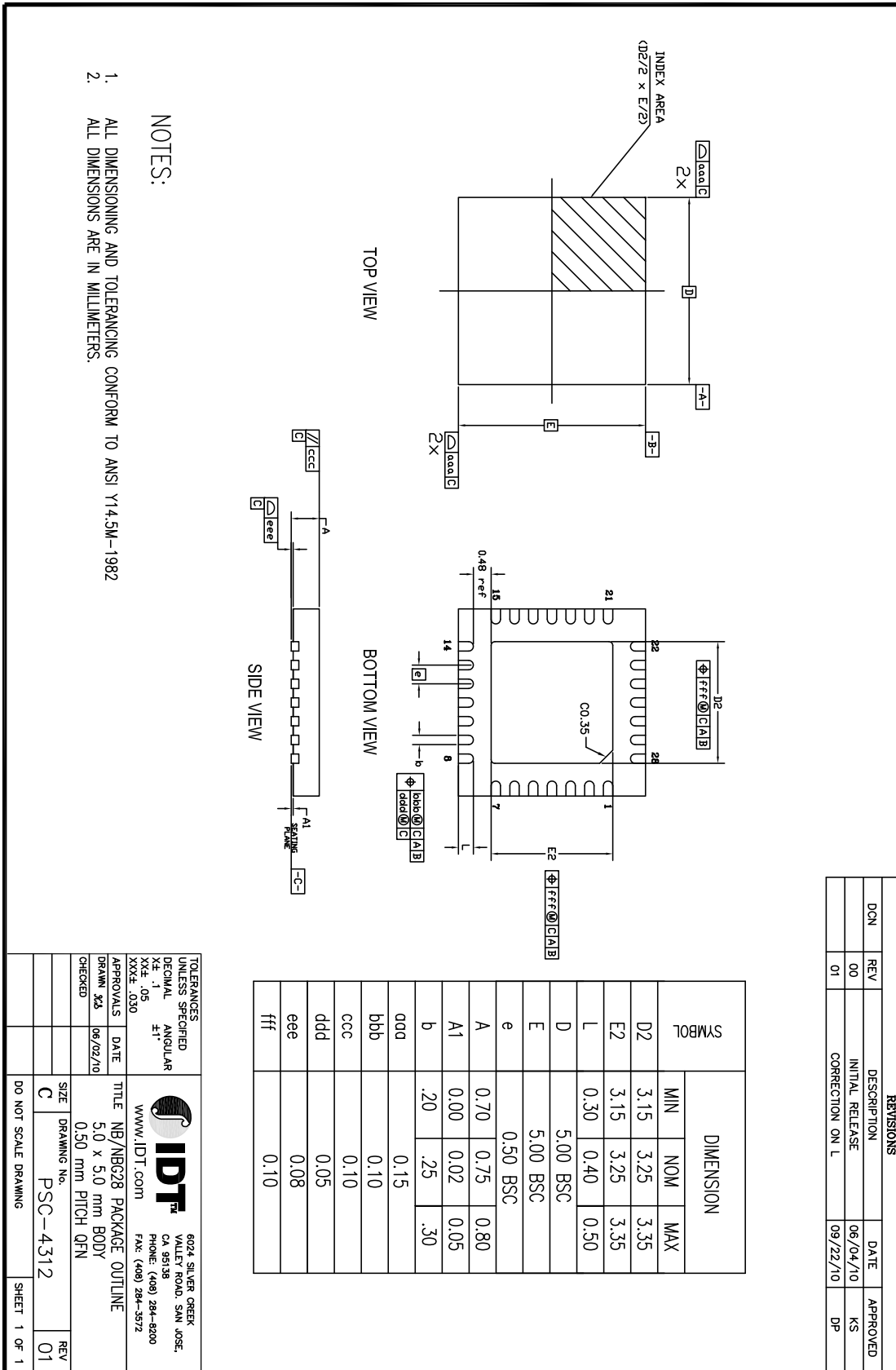

- NOTES:
1. ALL DIMENSIONING AND TOLERANCING CONFORM TO ANSI Y14.5M-1982
  2. ALL DIMENSIONS ARE IN MILLIMETERS.

REVISIONS			
REV	DESCRIPTION	DATE	APPROVED
00	INITIAL RELEASE	06/04/10	KS
01	CORRECTION ON L	09/22/10	DP

TOLERANCES UNLESS SPECIFIED

DECIMAL	ANGULAR
XXX .05	±1°
XXXX .030	

APPROVALS: DATE: 06/02/10

CHECKED:

SIZE: C

DRAWING No: PSC-4312

DO NOT SCALE DRAWING

SHEET 1 OF 1

REV 01

www.IDT.com

**IDT**

6024 SILVER CREEK VALLEY ROAD, SAN JOSE, CA 95138 PHONE: (408) 284-8200 FAX: (408) 284-3572

TITLE: NB/NB328 PACKAGE OUTLINE

5.0 x 5.0 mm BODY

0.50 mm PITCH QFN



## Ordering Information

Table 8. Ordering Information

Part/Order Number	Marking	Package	Shipping Packaging	Temperature
8P34S1208NBGI	P34S1208NBGI	“Lead-Free” 28 Lead VFQFN	Tray	-40°C to 85°C
8P34S1208NBGI8	P34S1208NBGI	“Lead-Free” 28 Lead VFQFN	Tape & Reel	-40°C to 85°C



## IMPORTANT NOTICE AND DISCLAIMER

RENESAS ELECTRONICS CORPORATION AND ITS SUBSIDIARIES (“RENESAS”) PROVIDES TECHNICAL SPECIFICATIONS AND RELIABILITY DATA (INCLUDING DATASHEETS), DESIGN RESOURCES (INCLUDING REFERENCE DESIGNS), APPLICATION OR OTHER DESIGN ADVICE, WEB TOOLS, SAFETY INFORMATION, AND OTHER RESOURCES “AS IS” AND WITH ALL FAULTS, AND DISCLAIMS ALL WARRANTIES, EXPRESS OR IMPLIED, INCLUDING, WITHOUT LIMITATION, ANY IMPLIED WARRANTIES OF MERCHANTABILITY, FITNESS FOR A PARTICULAR PURPOSE, OR NON-INFRINGEMENT OF THIRD PARTY INTELLECTUAL PROPERTY RIGHTS.

These resources are intended for developers skilled in the art designing with Renesas products. You are solely responsible for (1) selecting the appropriate products for your application, (2) designing, validating, and testing your application, and (3) ensuring your application meets applicable standards, and any other safety, security, or other requirements. These resources are subject to change without notice. Renesas grants you permission to use these resources only for development of an application that uses Renesas products. Other reproduction or use of these resources is strictly prohibited. No license is granted to any other Renesas intellectual property or to any third party intellectual property. Renesas disclaims responsibility for, and you will fully indemnify Renesas and its representatives against, any claims, damages, costs, losses, or liabilities arising out of your use of these resources. Renesas' products are provided only subject to Renesas' Terms and Conditions of Sale or other applicable terms agreed to in writing. No use of any Renesas resources expands or otherwise alters any applicable warranties or warranty disclaimers for these products.

(Rev.1.0 Mar 2020)

### Corporate Headquarters

TOYOSU FORESIA, 3-2-24 Toyosu,  
Koto-ku, Tokyo 135-0061, Japan  
[www.renesas.com](http://www.renesas.com)

### Contact Information

For further information on a product, technology, the most up-to-date version of a document, or your nearest sales office, please visit:  
[www.renesas.com/contact/](http://www.renesas.com/contact/)

### Trademarks

Renesas and the Renesas logo are trademarks of Renesas Electronics Corporation. All trademarks and registered trademarks are the property of their respective owners.