

Brief Description

The ZSLS7025, one of our ZSLS Family of LED control ICs, is a constant current boost converter designed for driving high-brightness LEDs. It is optimal for driving multiple white LEDs connected in series so that the LED current is uniform for better brightness and color control. The wide input voltage range and high output current enables diverse industrial, after-market automotive, and consumer lighting applications.

The ZSLS7025 output current is adjustable via an external current sense resistor and can deliver stable constant output current from a few milliamps up to 2A or higher.

The ZSLS7025 drives a constant current into the load. The control loop features a pulse frequency modulated (PFM) architecture that is inherently stable and does not need loop compensation.

The ZSLS7025 supports pulse-width modulation (PWM) or linear voltage dimming, which allows flexible control of the LED luminance.

The ZSLS7025 can operate in applications with a wide input voltage range from 5V to 100V. An integrated over-voltage protection (OVP) circuit protects the system, even under no-load conditions. The over-voltage protection is adjustable via external resistors R₁ and R₂.

Features

- Wide application input voltage range: 5V to 100V (Higher voltage supported. See section 2.1 in the data sheet.)
- Constant current output limited only by external component selection
- No loop compensation required
- Internal over-voltage protection
- Internal over-temperature protection
- Brightness control via PWM or DC voltage control signal input
- SOP-8 package

Benefits

- High efficiency: up to 95%
- Minimum bill of materials
- Small form-factor package

Available Support

- Demonstration Kit

Physical Characteristics

- Junction temperature: -40°C to 125°C
- RoHS compliant

ZSLS7025 Typical Application Circuit

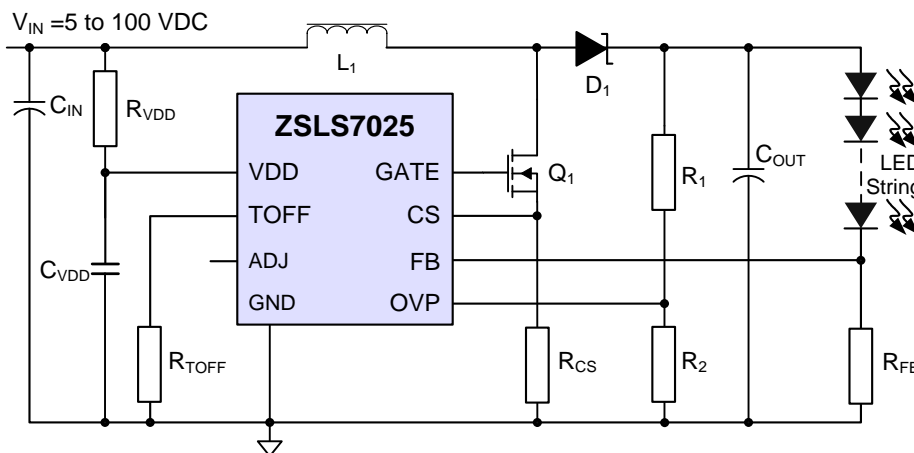

ZSLS7025 Block Diagram

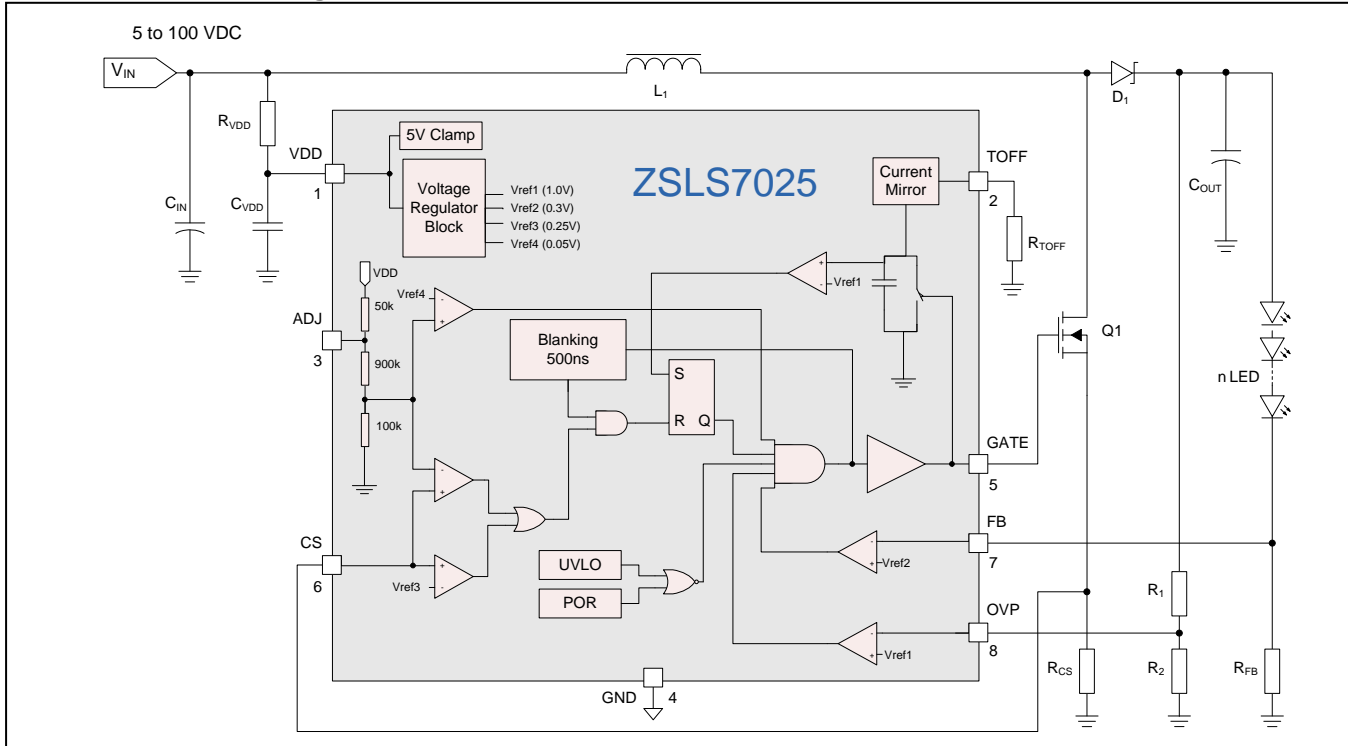

Typical Applications

- ❖ Retro-fit Lighting
- ❖ MR16 Lights
- ❖ SELV Lighting
- ❖ Signage and Outdoor Lighting
- ❖ Architectural/Building Lighting
- ❖ Replacement Tubes
- ❖ LED Backlighting
- ❖ General Purpose Low-Voltage Industrial and Consumer Applications

Ordering Information

Product Sales Code	Description	Package
ZSLS7025ZI1R	ZSLS7025 – Boost LED Driver	SOP-8 (Tape & Reel)
ZSLS7025KIT-D1	ZSLS7025PCB-D1 Demo Board, 1 ZLED-PCB10, and 5 ZSLS7025 ICs	Kit

Contents

1	IC Characteristics	5
1.1	Absolute Maximum/Minimum Ratings	5
1.2	Operating Conditions	5
1.3	Electrical Parameters	6
1.4	Typical Performance Characteristics Graphs	7
2	Circuit Description	9
2.1	ZSLS7025 Overview	9
2.2	Boost Converter	9
2.3	Internal 5V Regulator	10
2.4	Input Current	10
2.5	LED Current Control	10
2.6	Dimming Control	10
2.6.1	Dimming Control Using an External DC Control Signal	11
2.6.2	Dimming Control Using an RC Filter to Convert a PWM Signal to a DC Voltage	12
2.6.3	PWM Dimming with a Dimming Control MOSFET (Q ₂)	13
2.7	Peak Input Current Control	13
2.8	Setting the Minimum Off-Time t _{OFF_MIN}	14
2.9	Switching Frequency and Inductor Value	14
2.10	DC Power Loss	15
3	Operating Conditions	16
3.1	Under-Voltage Lockout	16
3.2	Over-Voltage Protection	16
4	Application Circuit Design	17
4.1	Applications	17
4.2	External Component Selection	17
4.2.1	Series Resistor R _{VDD}	17
4.2.2	Inductor L ₁	17
4.2.3	High Frequency Noise Filter Capacitor C _{VDD}	18
4.2.4	Input Capacitor C _{IN}	18
4.2.5	Output Capacitor C _{OUT} for Reducing Output Ripple	18
4.2.6	Schottky Rectifier Diode D ₁	18
4.2.7	External MOSFET Q ₁	18
4.3	Application Circuit Layout Requirements	19
4.4	Application Example	19
4.4.1	Selecting R _{VDD} , C _{IN} , and C _{VDD}	20
4.4.2	Selecting R _{TOFF} to Set Minimum t _{OFF}	20
4.4.3	Selecting R _{FB} to Set Output Current and C3	20
4.4.4	Selecting R ₃ , R ₄ , R ₅ and C ₁	21
4.4.5	R _{CS} for Setting Input Peak Current	22
4.4.6	L ₁ for Setting the Frequency	22
4.4.7	R ₁ and R ₂ for Setting OVP	23
4.4.8	Q ₁ External MOSFET and D ₁ Diode	23
5	ESD Protection	24

6	Pin Configuration and Package	24
7	Glossary	26
8	Ordering Information	26
9	Document Revision History	26

List of Figures

Figure 1.1	V_{IN} vs. I_{OUT} with $V_{OUT} = 40V$	7
Figure 1.2	V_{IN} vs. Efficiency with $V_{OUT} = 40V$	7
Figure 1.3	V_{OUT} vs. I_{OUT} with $V_{IN} = 12V$	7
Figure 1.4	V_{OUT} vs. Efficiency with $V_{IN} = 12V$	7
Figure 1.5	V_{IN} vs. I_{OUT} with $V_{OUT} = 48V$	7
Figure 1.6	V_{IN} vs. Efficiency with $V_{OUT} = 48V$	7
Figure 1.7	V_{OUT} vs. I_{OUT} with $V_{IN} = 24V$	8
Figure 1.8	V_{OUT} vs. Efficiency with $V_{IN} = 24V$	8
Figure 2.1	Typical ZSLS7025 Circuit Diagram	9
Figure 2.2	Example Circuit for Controlling Output Current via an External DC Control Voltage	11
Figure 2.3	RC Filter PWM Dimming Circuit	12
Figure 2.4	PWM Dimming Circuit Using a Dimming Control MOSFET (Q_2)	13
Figure 2.5	Minimum Off-Time t_{OFF_MIN} vs. R_{TOFF}	14
Figure 4.1	Typical ZSLS7025 Application Circuit	17
Figure 4.2	Application Design Example – RC Filter PWM Dimming Circuit	20
Figure 6.1	ZSLS7025 Pin Assignments	24
Figure 6.2	SOP-8 Package Dimensions and Pin Assignments	25

List of Tables

Table 1.1	Absolute Maximum Ratings	5
Table 1.2	Operating Conditions	5
Table 1.3	Electrical Parameters	6
Table 6.1	Pin Description SOP-8	24

1 IC Characteristics

Stresses beyond those listed under “Absolute Maximum/Minimum Ratings” (section 1.1) may cause permanent damage to the device. These are stress ratings only, and functional operation of the device at these or any other conditions beyond those recommended under “Recommended Operating Conditions” (section 1.2) is not implied. Exposure to absolute–maximum conditions for extended periods may affect device reliability.

1.1 Absolute Maximum/Minimum Ratings

Table 1.1 Absolute Maximum Ratings

No.	PARAMETER	SYMBOL	CONDITIONS	MIN	TYP	MAX	UNIT
1.1.1	Voltage on VDD pin (also see specification 1.2.2 and 1.2.3)	V_{DD}		-0.3		6	V
1.1.2	All other pins to GND			-0.3		6	V
1.1.3	Maximum input current on VDD pin ¹⁾	I_{DD}				10	mA
1.1.4	ESD performance		Human Body Model			±3.5	kV
1.1.5	Junction temperature	T_{jMAX}		-40		150	°C
1.1.6	Storage temperature	T_{ST}		-65		150	°C

1) Exceeding VDD maximum input current could cause the pin to not clamp at 5V.

1.2 Operating Conditions

Table 1.2 Operating Conditions

No.	PARAMETER	SYMBOL	CONDITIONS	MIN	TYP	MAX	UNIT
1.2.1	Junction temperature	T_{OP}		-40		125	°C
1.2.2	Supply voltage ¹⁾ (also see specification 1.1.1)	V_{IN}	Supply voltage connected to VDD pin via series resistor R_{VDD} (see section 4.2.1)	5		100	V
1.2.3	VDD pin ¹⁾²⁾ (also see specification 1.1.1)	V_{DD}	Supply voltage connected to VDD pin via series resistor R_{VDD} (see section 4.2.1)	4.3		5.6	V

1) Supply voltage should be connected to the VDD pin via R_{VDD} .
 2) Voltage set according to the clamping of the internal shunt regulator (see section 2.3).

1.3 Electrical Parameters

Except as noted, test conditions for the following specifications are $V_{IN} = 10V$, $R_{VDD} = 10K\Omega$, ADJ floating, and $T_{OP} = 25^{\circ}C$ (typical).

Production testing of the chip is performed at $25^{\circ}C$ unless otherwise stated. Functional operation of the chip and specified parameters at other temperatures are guaranteed by design, characterization, and process control.

Table 1.3 *Electrical Parameters*

No.	PARAMETER	SYMBOL	CONDITIONS	MIN	TYP	MAX	UNIT
1.3.1	VDD pin clamp voltage	V_{DD}	$R_{VDD} = 10K\Omega$	4.3	5	5.6	V
1.3.2	Under-voltage threshold	V_{UVLO_TH}	V_{DD} rising	2.0	2.7	3.0	V
1.3.3	Under-voltage threshold hysteresis	V_{UVLO_HYS}			300		mV
1.3.4	Quiescent supply current	I_{SS}	$V_{DD} = 5V$		250	400	μA
			$V_{DD} = 2.5V$ (under-voltage)		50	75	μA
1.3.5	Peak-current sense threshold voltage	V_{CS_TH}	ADJ pin = 5V	215	240	265	mV
1.3.6	Peak current sense blanking interval	t_{BLANK}	$V_{CS} = V_{CS_TH} + 50mV$		500		ns
1.3.7	Fixed turn-off interval	t_{OFF}	$R_{TOFF} = 250K\Omega$		10		μs
1.3.8	Peak-current control low threshold voltage	V_{ADJ}			0.5		V
	Peak-current control high threshold voltage				2.4		V
1.3.9	Over-temperature protection (OTP) threshold	T_{OTP}			125		$^{\circ}C$
1.3.10	OTP threshold hysteresis	T_{OTP_HYS}			20		$^{\circ}C$
1.3.11	Internal feedback reference voltage	V_{FB}		0.29	0.3	0.31	V
1.3.12	Over-voltage input threshold	V_{OVP_TH}		0.9	1.0	1.1	V

1.4 Typical Performance Characteristics Graphs

Figure 1.1 V_{IN} vs. I_{OUT} with $V_{OUT} = 40V$

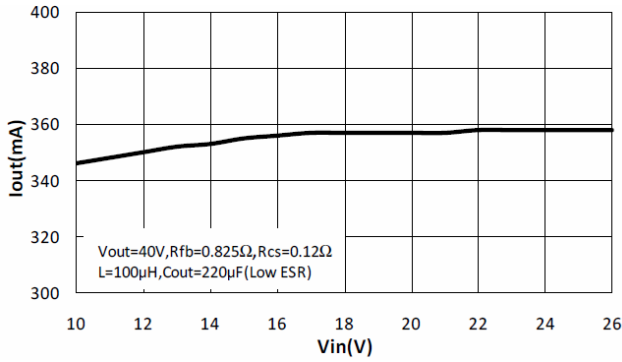

Figure 1.2 V_{IN} vs. Efficiency with $V_{OUT} = 40V$

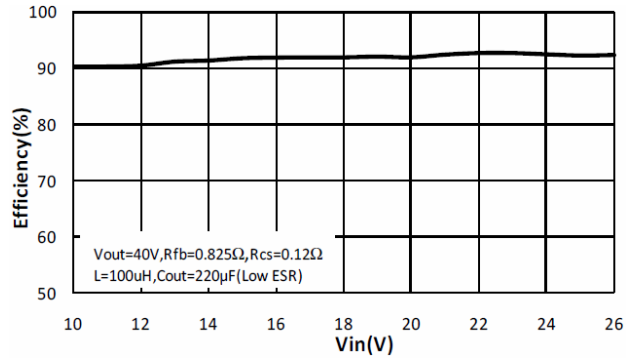

Figure 1.3 V_{OUT} vs. I_{OUT} with $V_{IN} = 12V$

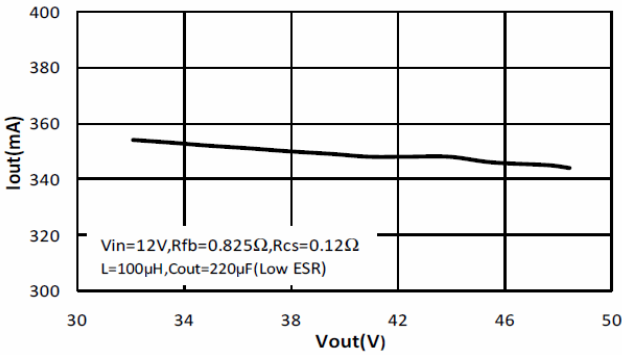

Figure 1.4 V_{OUT} vs. Efficiency with $V_{IN} = 12V$

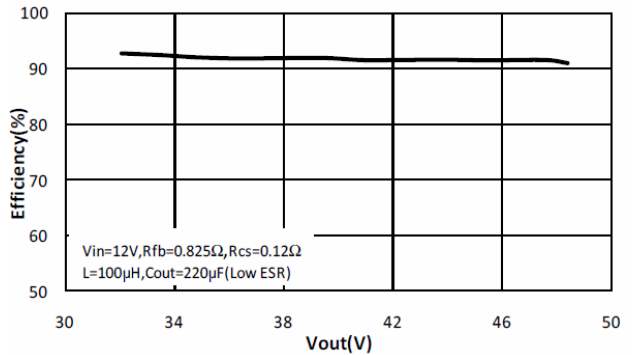

Figure 1.5 V_{IN} vs. I_{OUT} with $V_{OUT} = 48V$

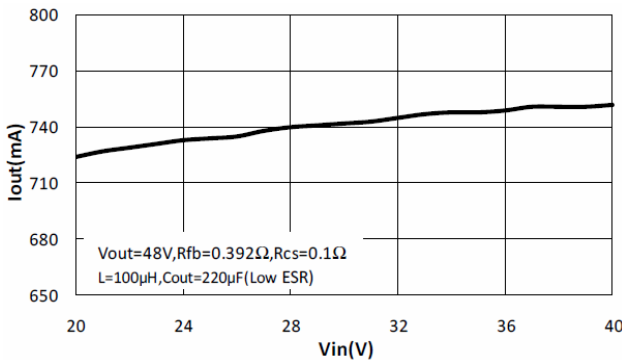

Figure 1.6 V_{IN} vs. Efficiency with $V_{OUT} = 48V$

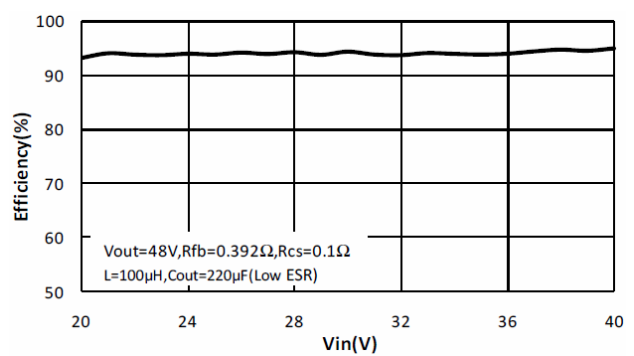

Figure 1.7 V_{OUT} vs. I_{OUT} with $V_{IN} = 24V$

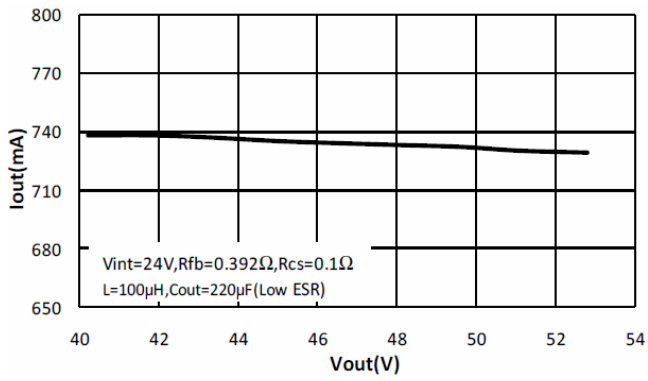
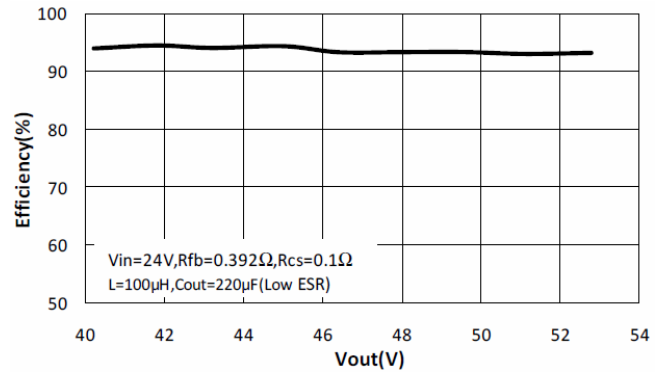

Figure 1.8 V_{OUT} vs. Efficiency with $V_{IN} = 24V$



2 Circuit Description

2.1 ZSLS7025 Overview

The ZSLS7025 is a constant current boost converter. Its output current is adjustable via an external current sense resistor, and it can deliver stable constant output current from a few milliamps up to 2A or higher.

The ZSLS7025 drives a constant current into the load, automatically adjusting the output voltage according to the load. The control loop features a pulse frequency modulated (PFM) architecture that is inherently stable and does not need loop compensation.

The ZSLS7025 can operate in applications with a wide input voltage range from 5V to 100V. V_{IN} voltages above 100V can be supported if logic level MOSFETs for the higher voltage rating are available. An integrated over-voltage protection (OVP) circuit protects the system, even under no-load conditions. The over-voltage protection is adjustable via external resistors R_1 and R_2 . The minimum load voltage must always be higher than the maximum V_{IN} , and the drain voltage rating of the switching transistor (Q_1) must be higher than the over-voltage shut-off limit.

Note: The ZSLS7025 has an internal 5V shunt regulator connected to the VDD pin. The R_{VDD} series resistor must be connected between the VDD pin and V_{IN} to limit current flow.

See section 4.2 for requirements for selecting the external components referred to in the following sections.

Figure 2.1 Typical ZSLS7025 Circuit Diagram

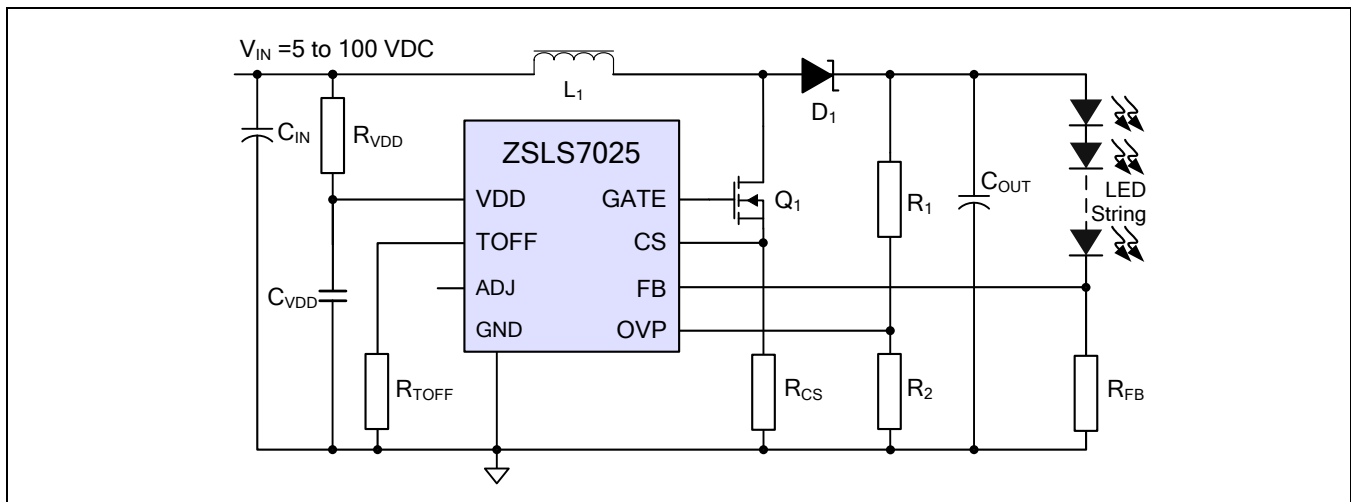

2.2 Boost Converter

The ZSLS7025's boost converter uses a peak-current mode topology. The CS pin voltage in conjunction with the current-sense resistor R_{CS} determines the peak current in the inductor (L_1). Q_1 is turned on and off by the output of an RS flip-flop that is set when the voltage on the FB pin drops below the internal threshold of 300 mV. After Q_1 has been switched on, a blanking timer disables the current sense input CS to avoid immediate spurious shut-off as a result of the switching transient when Q_1 discharges the parasitic capacitances on its drain node to ground. After the blanking time t_{BLANK} (see parameter 1.3.6 in section 1.3) has elapsed, the current through the inductor is sensed as a voltage drop across R_{CS} , and when the voltage reaches the peak-current sense threshold voltage V_{CS_TH} (see parameter 1.3.5 in section 1.3), the flip-flop is reset and Q_1 is turned off. Once Q_1 is turned off, the inductor reverses polarity, providing the voltage boost, and the inductor current will decrease until the input voltage on the FB pin drops below the internal feedback reference voltage V_{FB} , (see parameter 1.3.11 in section 1.3). Q_1 is then turned on again, and this operation repeats in each cycle.

When the input voltage on the FB pin does not exceed the internal feedback reference voltage V_{FB} , such as during start-up, Q_1 will remain off for the configured minimum t_{OFF} time (see sections 2.8 and 2.9), and then it is switched on again.

2.3 Internal 5V Regulator

The ZSLS7025 includes an internal 5V (typical) shunt regulator connected to the VDD pin which maintains a 5V power supply for the gate driver and control circuitry. Connect V_{IN} to the VDD pin via the current limiting series resistor R_{VDD} (see section 4.2.1 for required values). Consideration should be given to the tolerances on the VDD pin operating conditions (see section 1.2, parameter 1.2.3) and V_{IN} .

2.4 Input Current

The current required by the ZSLS7025 is 0.25mA (typical) plus the switching current of the external MOSFET, Q_1 . The switching frequency of Q_1 affects the amount of current required, as does Q_1 's gate charge requirement (found in the MOSFET manufacturer's data sheet).

$$I_{IN} \approx 0.25\text{mA} + Q_G \times f_S \quad (1)$$

Where

f_S = switching frequency of Q_1

Q_G = gate charge of Q_1

2.5 LED Current Control

The ZSLS7025 regulates the LED current by sensing the voltage across the external feedback resistor R_{FB} in series with the LEDs. The voltage is sensed via the FB pin where the internal feedback reference voltage V_{FB} is 0.3V (typical; see section 1.3, parameter 1.3.11). The LED current can easily be set according to equation (2).

$$I_{OUT} = \frac{V_{FB}}{R_{FB}} = \frac{0.3\text{V}}{R_{FB}} \quad (2)$$

Where

I_{OUT} = Average output current through the LED(s) in amperes

V_{FB} = Internal feedback reference voltage

Note: For an accurate LED current, a precision resistor is required for R_{FB} (1% is recommended).

2.6 Dimming Control

There are three options for LED dimming:

- DC voltage dimming control
- RC-filtered PWM signal dimming control
- PWM signal with a dimming control MOSFET(Q_2)

2.6.1 Dimming Control Using an External DC Control Signal

The LED output current can be set below the nominal average value defined by equation (2) using an external DC voltage control signal superimposed on the FB pin as shown in the example circuit in Figure 2.2. As the DC control signal, V_{DC} , increases, the current through R_3 increases with a subsequent increase in the voltage at the FB pin. This causes the ZSLS7025 to compensate by reducing the output current through the LED string. Consequently, the output current is inversely proportional to the DC control voltage.

Note: It is important to ensure that the LED output voltage V_{OUT} remains higher than the input voltage V_{IN} in dimming applications.

The output current controlled by the DC voltage on FB can be calculated using equation (3).

$$I_{OUT} = \frac{V_{FB} - \left(\frac{R_3 \times (V_{DC} - V_{FB})}{R_4} \right)}{R_{FB}} \quad (3)$$

Where

I_{OUT} = Output current through the LED(s) with a DC control voltage

V_{FB} = Internal feedback reference voltage (see section 1.3, parameter 1.3.11)

V_{DC} = External DC control voltage

Figure 2.2 Example Circuit for Controlling Output Current via an External DC Control Voltage

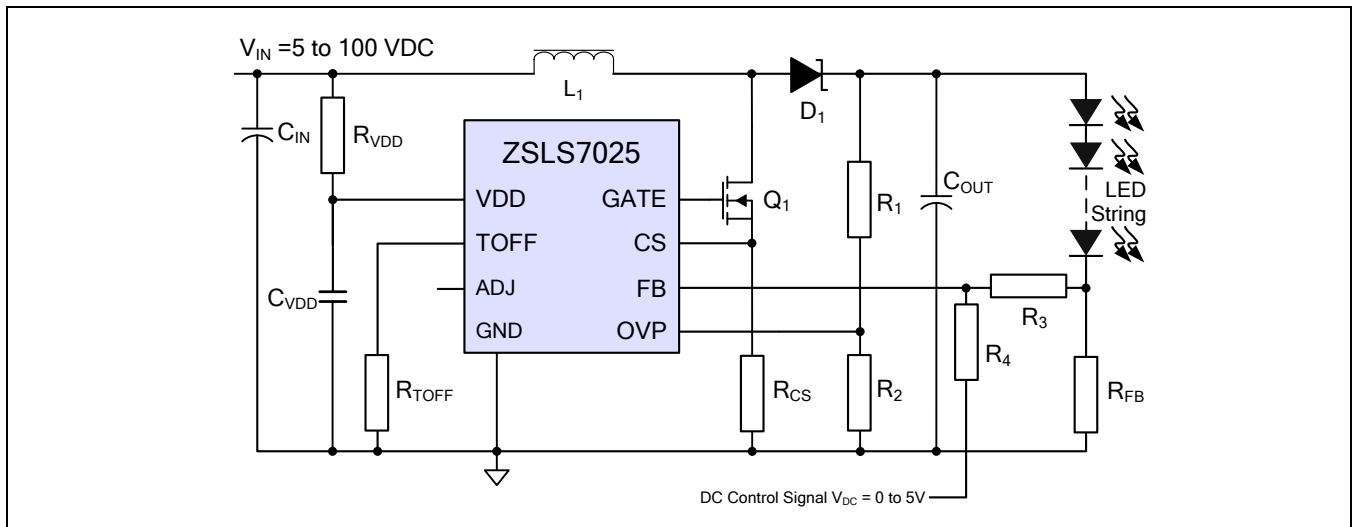

2.6.2 Dimming Control Using an RC Filter to Convert a PWM Signal to a DC Voltage

As shown in Figure 2.3, a filtered PWM signal can be used as an adjustable DC voltage for LED dimming control, and it functions the same as the DC control signal described in section 2.6.1. An external RC filter converts the PWM signal to a DC voltage, which is summed with the FB voltage to regulate the output current. Using a fixed frequency PWM signal and changing the duty cycle adjusts the average LED current. The LED current can be calculated with equation (4):

$$I_{OUT} = \frac{V_{FB} - \left(\frac{R_3 \times (V_{PWM} \times D_{PWM} - V_{FB})}{R_4 + R_5} \right)}{R_{FB}} \quad (4)$$

Where

- I_{OUT} = Output current through the LED(s) with a PWM control voltage
- V_{FB} = Internal feedback reference voltage (see section 1.3, parameter 1.3.11)
- V_{PWM} = External PWM control voltage
- D_{PWM} = Duty cycle of the PWM control signal

The LED current is inversely proportional to the PWM duty cycle; i.e., when the PWM signal has a 100% duty cycle, the output current is minimum, ideally zero, and when the PWM signal has a 0% duty cycle, the output current is at its maximum. See the example in section 4.4 for more details.

Note: Care must be taken to ensure that the minimum required current is not already exceeded when the LEDs are connected to V_{IN} .

Figure 2.3 RC Filter PWM Dimming Circuit

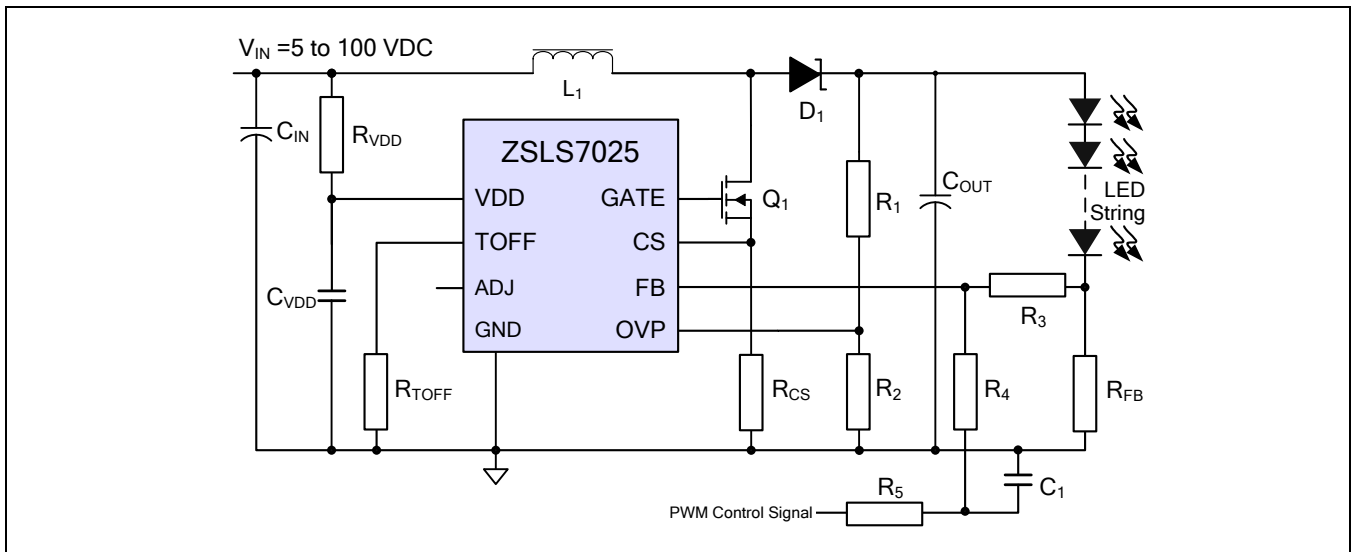

2.6.3 PWM Dimming with a Dimming Control MOSFET (Q₂)

Figure 2.4 shows the configuration for using an external PWM signal with a dimming control MOSFET Q₂. When the PWM input is high (V_H>2.4V), Q₂ is on and the ZSLS7025 operates normally to regulate the output current. When the PWM signal is low (V_L<0.5V), Q₂ is off; the input voltage on the FB pin will be below V_{FB} and the ZSLS7025 is shutdown. Using a fixed frequency PWM signal and changing the duty cycle adjusts the average LED current. The recommended 5V PWM frequency is between 200Hz and 1KHz.

Figure 2.4 PWM Dimming Circuit Using a Dimming Control MOSFET (Q₂)

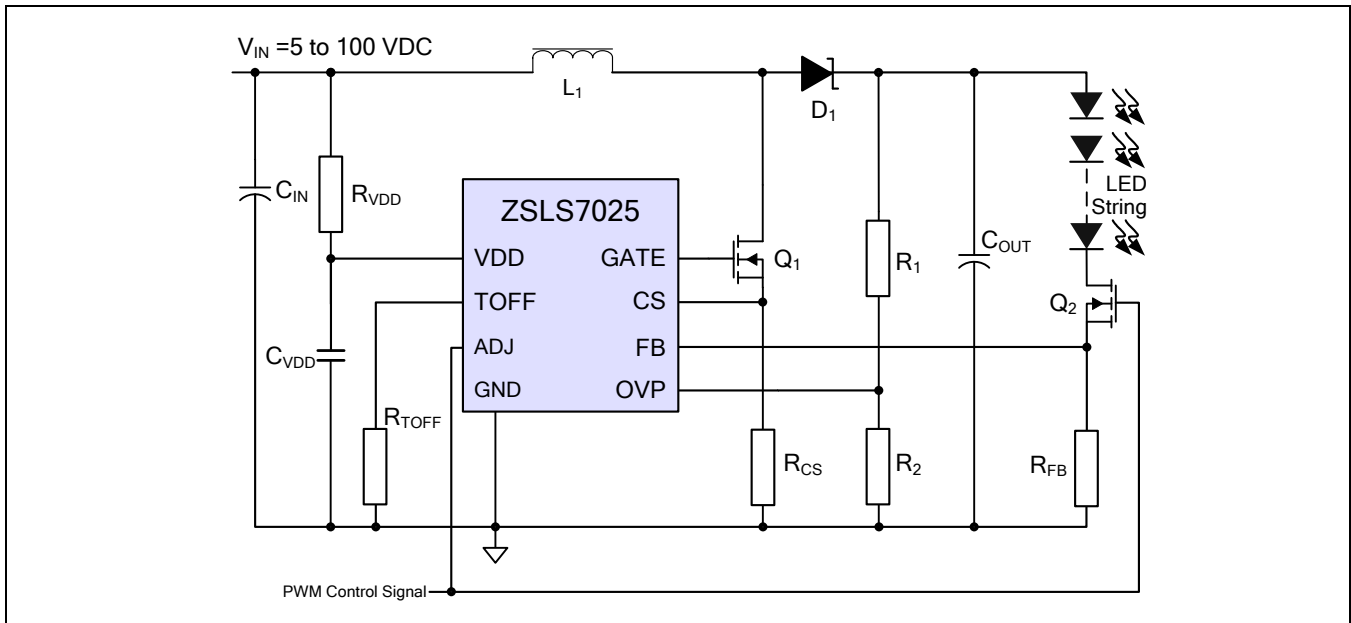

2.7 Peak Input Current Control

The ZSLS7025 limits the peak inductor current and therefore the peak input current through the feedback path of R_{CS} connected from the source of the external MOSFET (Q₁) to ground. The required average input current is based on the boost ratio V_{OUT}/V_{IN} and the designed value for average LED current. The required average input current can be calculated with equation (5):

$$I_{IN_AVG} = \frac{V_{OUT} \times I_{OUT}}{V_{IN} \times \eta} \tag{5}$$

Where

η = Assumed power conversion efficiency (recommended value for calculation: 0.9)

In general, setting the peak inductor current to 1.5 times the average input current is sufficient to maintain good regulation of the output current.

$$I_{IN_PEAK} = 1.5 \times I_{IN_AVG} = \frac{V_{CS_TH}}{R_{CS}} \tag{6}$$

Where

$$V_{CS_TH} = V_{ADJ}/10 \text{ if } 0.5V < V_{ADJ} \leq 2.4V \text{ or}$$

$$V_{CS_TH} = 0.24V \text{ if } V_{ADJ} > 2.4V \text{ or if the ADJ pin is floating}$$

2.8 Setting the Minimum Off-Time t_{OFF_MIN}

The ZSLS7025 operates in a pulsed frequency modulation (PFM) mode. In nominal operation, on-time and off-time are determined according to equations (8), (9), (10), and (11). In most applications, the recommended value for t_{OFF_MIN} is 1 μ s. The relationship between t_{OFF_MIN} and R_{TOFF} is shown in equation (7) and Where t_{OFF_MIN} is in μ s and R_{TOFF} is in Ω .

Figure 2.5. t_{OFF_MIN} is valid as long as V_{FB} has not reached the threshold of 300 mV.

$$t_{OFF_MIN} = 40 \times 10^{-12} \times R_{TOFF} \tag{7}$$

Where t_{OFF_MIN} is in μ s and R_{TOFF} is in Ω .

Figure 2.5 Minimum Off-Time t_{OFF_MIN} vs. R_{TOFF}



2.9 Switching Frequency and Inductor Value

The inductance value of the inductor (L_1) directly determines the switching frequency of the converter. Under fixed conditions, the inductance is inversely proportional to the switching frequency; i.e., the larger the inductance, the lower the switching frequency. A higher switching frequency will reduce the value required for the inductor but will increase the switching loss in the external MOSFET, Q_1 (see section 2.4).

The switching frequency f in Hertz can be calculated from t_{ON} and t_{OFF} in seconds with equation (8).

$$f = \frac{1}{(t_{ON} + t_{OFF})} \quad (8)$$

The ripple current in the inductor can be calculated with equation (9).

$$I_{RIPPLE} = 2 \times (I_{IN_PEAK} - I_{IN_AVG}) \quad (9)$$

The Q_1 on-time, t_{ON} , can be calculated with equation (10).

$$t_{ON} \approx \frac{(I_{RIPPLE} \times L_1)}{V_{IN} - I_{IN_AVG} \times (R_L + R_{DS(ON)} + R_{CS})} \quad (10)$$

Where

R_L = the DC resistance of inductor L_1 in Ω

$R_{DS(ON)}$ = the on-resistance of Q_1 in Ω (see manufacturer's specifications)

L_1 = the value of the inductor L_1 in Henries

The Q_1 off-time, t_{OFF} , can be calculated with equation (11).

$$t_{OFF} \approx \frac{I_{RIPPLE} \times L_1}{V_{OUT} + V_D + (I_{IN_AVG} \times R_L) - V_{IN}} \quad (11)$$

Where

V_D = the forward voltage of the diode D_1 at the required load current in volts

Note: The selection of inductor L_1 must ensure that t_{OFF} is longer than the t_{OFF_MIN} as calculated in equation (7). If not, the converter cannot output the required current.

The recommended switching frequency is $20\text{kHz} < f < 200\text{kHz}$. Lower than 20kHz will cause audio noise of the inductor, and a frequency that is too high will increase the switching loss in Q_1 .

With a fixed V_{IN} , V_{OUT} , I_{IN_AVG} , and I_{IN_PEAK} , the switching frequency is inversely proportional to the inductor value.

2.10 DC Power Loss

The $R_{DS(ON)}$ of the external MOSFET, Q_1 , determines the DC power loss, which can be calculated with equation (12).

$$P_{DISS} \approx I_{IN_AVG}^2 \times R_{DS(ON)} \times D_{Q1} \approx I_{IN_AVG}^2 \times R_{DS(ON)} \times \left(1 - \frac{V_{IN}}{V_{OUT}}\right) \times \frac{1}{\eta} \quad (12)$$

Where

D_{Q1} = the duty cycle for Q_1

η = Assumed power conversion efficiency (recommended value for calculation: 0.9)

3 Operating Conditions

3.1 Under-Voltage Lockout

The under-voltage lockout (UVLO) function monitors the voltage on the ZSLS7025's VDD pin. If this voltage is lower than the UVLO threshold minus the UVLO hysteresis ($V_{UVLO_TH} - V_{UVLO_HYS}$), the ZSLS7025 is disabled.

If the voltage on the VDD pin reaches a level higher than the UVLO threshold (V_{UVLO_TH}), the lock-out function turns off and the ZSLS7025 is re-enabled. See parameters 1.3.2 and 1.3.3 in section 1.3 for the V_{UVLO_TH} threshold and V_{UVLO_HYS} hysteresis, respectively.

3.2 Over-Voltage Protection

Open-load protection is achieved through the ZSLS7025's over-voltage protection (OVP). In boost converters, an LED string failure can cause the feedback voltage (V_{FB}) to always be zero. If this happens, the ZSLS7025 will keep boosting the output voltage higher and higher. If the output voltage reaches the programmed OVP threshold, the protection mechanism will be triggered and stop the switching action. To ensure that the circuit functions properly, the OVP setting resistor divider, R_1 and R_2 , must be set with appropriate values given by equation (13). The recommended OVP voltage is either 1.25 times the normal output voltage or 5V higher than the normal output voltage, whichever is higher.

$$V_{OVP} = V_{OVP_TH} \times \frac{(R_1 + R_2)}{R_2} \tag{13}$$

Where

V_{OVP_TH} = Over-voltage input threshold: 1.0V (typical; see parameter 1.3.12 in section 1.3)

V_{OVP} = Output voltage OVP level

4 Application Circuit Design

4.1 Applications

The ZSLS7025 is ideal for driving white HB-LEDs in diverse industrial, after-market automotive, and consumer lighting applications using low supply voltages, such as SELV applications. It is optimal for driving multiple white HB-LEDs connected in series so that the LED current is uniform for better brightness and color control. It features a wide input range and high output current.

Figure 4.1 demonstrates the typical application with the external components described in section 4.2. Figure 2.2, Figure 2.3, and Figure 2.4 demonstrate various dimming applications.

Figure 4.1 Typical ZSLS7025 Application Circuit

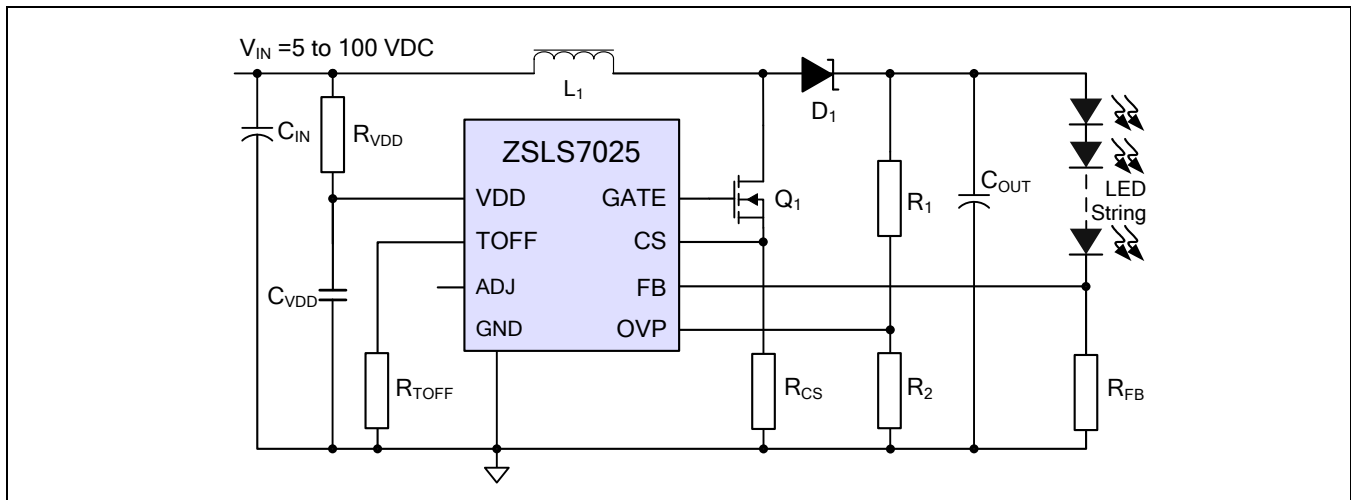

4.2 External Component Selection

Note: Also see section 4.3 for layout guidelines for the following external components.

4.2.1 Series Resistor R_{VDD}

The ZSLS7025 has an internal 5V shunt regulator connected to the VDD pin. The R_{VDD} series resistor must be connected between the VDD pin and V_{IN} to limit current flow. See section 2.1 regarding input voltages over 100V.

4.2.2 Inductor L_1

See section 2.9 for calculating the proper value for L_1 . Select an inductor with a current rating higher than the input average current and a saturation current over the calculated peak current. To calculate the worst case inductor peak current, use the minimum input voltage, maximum output voltage, and maximum total LED current. Also ensure that the inductor has a low DCR (copper wire resistance) to minimize the I^2R power loss.

4.2.3 High Frequency Noise Filter Capacitor C_{VDD}

External capacitor C_{VDD} forms a high-frequency noise filter for the VDD pin. For all configurations, use C_{VDD} to bypass the VDD pin using a low ESR capacitor (a 10 μ F ceramic capacitor is recommended) to provide a high frequency path to GND.

4.2.4 Input Capacitor C_{IN}

The C_{IN} input capacitor connected to V_{IN} will supply the transient input current for the power inductor. A value of 100 μ F or higher is recommended to prevent excessive input voltage ripple. Also see section 4.2.3.

4.2.5 Output Capacitor C_{OUT} for Reducing Output Ripple

The output capacitor (C_{OUT}) holds the output current while the Q_1 external MOSFET turns ON. This capacitor directly impacts the line regulation and the load regulation.

Using a low ESR capacitor can minimize output ripple voltage and improve output current regulation. For most applications, a 220 μ F low ESR capacitor will be sufficient. Proportionally lower ripple can be achieved with higher capacitor values.

4.2.6 Schottky Rectifier Diode D_1

The D_1 external diode for the ZSLS7025 should be a Schottky diode with a low forward voltage drop and fast switching speed. The diode's average current rating must exceed the application's average output current. The diode's maximum reverse voltage rating must exceed the over-voltage protection of the application. For PWM dimming applications, note the reverse leakage of the Schottky diode. Lower leakage current will drain the output capacitor less during PWM low periods, allowing for higher PWM dimming ratios.

4.2.7 External MOSFET Q_1

The Q_1 external MOSFET must have a V_{DS} rating that exceeds the maximum over-voltage protection (OVP) level configured for the application. The $V_{GS(th)}$ of the MOSFET should be not higher than 4V. The MOSFET's current rating must be higher than the input peak current (I_{IN_PEAK}). Determine the power dissipation within Q_1 and check if the thermal resistance of the MOSFET package causes the junction temperature to exceed maximum ratings. Also see section 2.10 regarding the effect of the MOSFET $R_{DS(ON)}$ on DC power loss.

4.3 Application Circuit Layout Requirements

The guidelines in this section are strongly recommended when laying out application circuits. As for all switching power supplies, especially those providing high current and using high switching frequencies, layout is an important design step. If the layout is not well-designed, the regulator could show instability as well as EMI problems. For additional guidelines, refer to the IDT application note *PCB Layout Design Guidelines for LED Driver Circuits* available at <http://www.IDT.com>.

- Wide traces should be used for connection of the high current loop to minimize the EMI and unnecessary loss.
- The external components ground should be connected to the ZSLS7025 ground and should be as short as possible. It is especially important that the R_{FB} ground to ZSLS7025 ground connection is as short and wide as possible to have an accurate LED current.
- The capacitors C_{IN} , C_{VDD} , and C_{OUT} should be placed as close as possible to the ZSLS7025 for good filtering. It is especially important that the C_{OUT} output capacitor connection is as short and wide as possible.
- The Q_1 external MOSFET drain is a fast switching node (also applies to Q_2 if the PWM is accomplished with a dimming control MOSFET as described in section 2.6.3). The inductor L_1 and Schottky diode D_1 should be placed as close as possible to the drain, and the connection should be kept as short and wide as possible. Avoid other traces crossing and routing too long in parallel with this node to minimize the noise coupling into these traces. The feedback pins (i.e., CS, FB, OVP) should be as short as possible and routed away from the inductor, Schottky diode, and Q_1 . The feedback pins and feedback network should be shielded with a ground plane or trace to minimize noise coupling into this circuit.
- The thermal pad on the back of the external MOSFET package must be soldered to the large ground plane for ideal heat distribution.

4.4 Application Example

This section provides an example of an application design for the ZSLS7025 for the RC-filter PWM application described in section 2.6.2 and shown again for reference in Figure 4.2.

Design criteria:

$$V_{IN} = 12 \text{ to } 24 \text{ V}$$

$$I_{OUT} = 350\text{mA}$$

$$V_{OUT} = 30 \text{ to } 40\text{V} \text{ (9 to 12 LEDs, } V_f = 3.3\text{V)}$$

To calculate the worst case parameters, use the minimum input voltage, maximum output voltage, and maximum output current; i.e., $V_{IN} = 12\text{V}$, $I_{OUT} = 350\text{mA}$, and $V_{OUT} \approx 40\text{V}$ (12 LEDs, $V_f = 3.3\text{V}$).

Figure 4.2 Application Design Example – RC Filter PWM Dimming Circuit

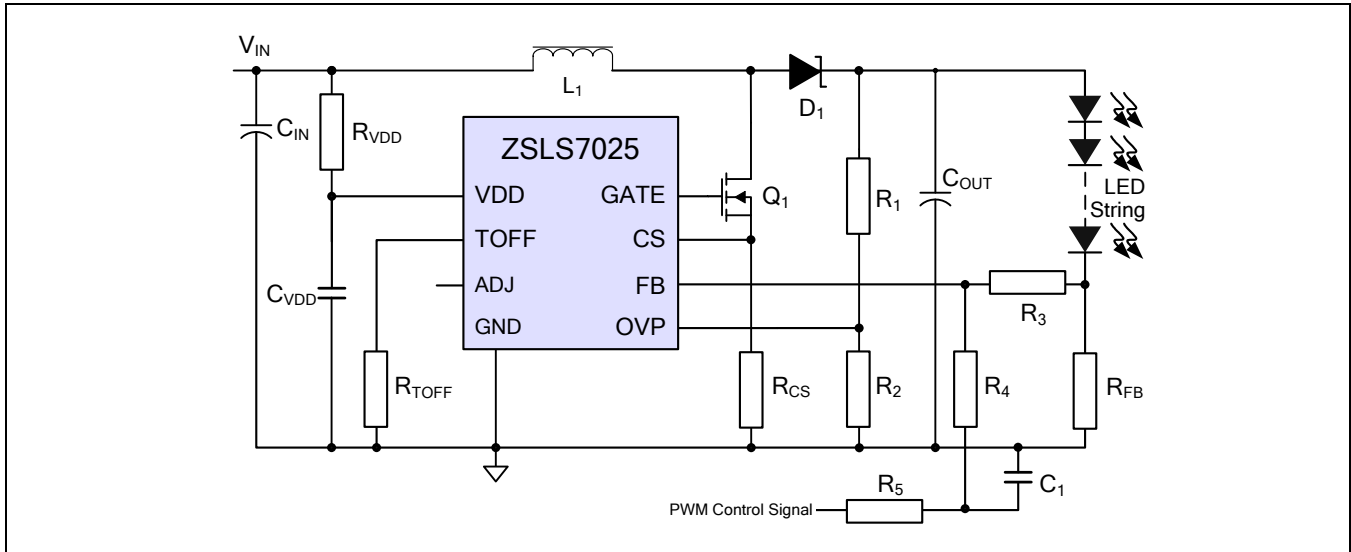

4.4.1 Selecting R_{VDD} , C_{IN} , and C_{VDD}

Assume $I_{IN} = 2.5\text{mA}$.

$$R_{VDD} = \frac{V_{IN} - V_{DD}}{I_{IN}} \approx 3\text{k}\Omega \quad (14)$$

→ Choose C_{IN} as $220\mu\text{F}/35\text{V}$ and C_{VDD} as $10\mu\text{F}/16\text{V}$.

4.4.2 Selecting R_{TOFF} to Set Minimum t_{OFF}

The recommended value for t_{OFF_MIN} is $1\mu\text{s}$.

$$t_{OFF_MIN} = 40 \times 10^{-12} \times R_{TOFF} = 1\mu\text{s} \quad (15)$$

→ Choose $R_{TOFF} = 24\text{k}\Omega$.

4.4.3 Selecting R_{FB} to Set Output Current and $C3$

$$R_{FB} = \frac{V_{FB_TH}}{I_{OUT}} \approx 0.86\Omega \quad (16)$$

→ Choose $C3 = 220\mu\text{F}/63\text{V}$ (low ESR electrolytic capacitor).

4.4.4 Selecting R₃, R₄, R₅ and C₁

R₃, R₄, and R₅ can be obtained by

$$I_{OUT} = \frac{V_{FB} - \left(\frac{R_3 \times (V_{PWM} \times D_{PWM} - V_{FB})}{R_4 + R_5} \right)}{R_{FB}} \quad (17)$$

Substitute D_{PWM}=100%, V_{PWM}= 5V, and I_{OUT}=0 in the equation, and the result is

$$0 = \frac{0.3 - \left(\frac{R_3 \times (5 \times 100\% - 0.3)}{R_4 + R_5} \right)}{0.86} \quad (18)$$

which can be simplified to

$$15.66 \times R_3 = R_4 + R_5$$

The low pass filter formed by R₅ and C₁ must have a corner frequency much lower than the PWM frequency. As the corner frequency of the filter decreases, the response time of the LED current to changes in PWM increases. Choose a corner frequency 50 times lower than f_{PWM}.

$$R_5 \times C_1 \geq \frac{50}{2\pi f_{PWM}} \quad (19)$$

Assume f_{PWM} is 200Hz (or higher) and choose C₁ = 0.1μF, and the result is R₅ ≥400kΩ.

→ Choose C₄ = 0.1μF, R₅ = 400kΩ.

Choose a nominal value for R₄, and then calculate R₃.

→ Choose R₄ = 10kΩ, then R₃ = 26.2kΩ.

Substitute D_{PWM}=0, V_{PWM}= 5V and I_{OUT} = 350mA in the equation, and the result is

$$I_{OUT} = \frac{V_{FB} - \left(\frac{R_3 \times (V_{PWM} \times D_{PWM} - V_{FB})}{R_4 + R_5} \right)}{R_{FB}} = \frac{0.3 - \left(\frac{26.2 \times (5 \times 0\% - 0.3)}{400 + 10} \right)}{R_{FB}} = 0.35A \quad (20)$$

So, R_{FB} =0.91Ω. (With the RC filter PWM dimming, R_{FB} will be different than in the no dimming application shown in Figure 2.1.)

4.4.5 R_{CS} for Setting Input Peak Current

Assume that

$$\begin{aligned} I_{IN_PEAK} &= 1.5 \times I_{IN_AVG} = 1.5 \times \frac{V_{OUT} \times I_{OUT}}{V_{IN} \times \eta} \\ &= 1.5 \times \frac{40 \times 0.35}{12 \times 0.9} \approx 1.95A \end{aligned} \quad (21)$$

Where η is the assumed power conversion efficiency (the recommended value for this calculation is 0.9)

$$R_{CS} = \frac{V_{CS_TH}}{I_{IN_PEAK}} = 0.123\Omega \quad (22)$$

→ Choose $R_{CS} = 0.123\Omega$, $I_{IN_PEAK} = 1.95A$

4.4.6 L₁ for Setting the Frequency

Input average current:

$$I_{IN_AVG} = \frac{V_{OUT} \times I_{OUT}}{V_{IN} \times \eta} = 1.3A \quad (23)$$

The ripple current in the inductor:

$$I_{RIPPLE} = 2 \times (I_{IN_PEAK} - I_{IN_AVG}) = 1.3A \quad (24)$$

According to $t_{OFF} > t_{OFF_MIN}$:

$$t_{OFF} = \frac{I_{RIPPLE} \times L_1}{V_{OUT} + V_D + (I_{IN_AVG} \times R_L) - V_{IN}} > 1\mu s \quad (25)$$

This gives $L_1 > 22\mu H$.

Assume $L_1 = 22\mu H$ and $R_L + R_{DS(ON)} + R_{CS} = 0.4\Omega$

$$t_{ON} = \frac{(I_{RIPPLE} \times L_1)}{V_{IN} - I_{IN_AVG} \times (R_L + R_{DS(ON)} + R_{CS})} \approx 2.5\mu s \quad (26)$$

Then the assumed switching frequency:

$$f' = \frac{1}{(t_{ON} + t_{OFF})} \approx 285kHz \quad (27)$$

The recommended switching frequency, $20\text{kHz} < f < 200\text{kHz}$, according to the switching frequency, is inversely proportional to the inductor value; for example, select $L_1=100\ \mu\text{H}$.

Therefore

$$f = f' \times \frac{22}{100} \approx 63\text{kHz} \tag{28}$$

The saturation current of the inductor must exceed the input peak current ($I_{\text{IN_PEAK}}$).

4.4.7 R_1 and R_2 for Setting OVP

Set $V_{\text{OVP}} = V_{\text{OUT}} + 5\text{V} = 45\text{V}$

$$V_{\text{OVP}} = V_{\text{OVP_TH}} \times \frac{(R_1 + R_2)}{R_2} \tag{29}$$

→Choose $R_2 = 10\text{k}\Omega$, then $R_1 = 470\text{k}\Omega$.

4.4.8 Q_1 External MOSFET and D_1 Diode

Power losses in the Q_1 external MOSFET should be minimized. Conduction losses increase with $R_{\text{DS(on)}}$, and switching losses increase with gate/drain charge and frequency. Therefore, selecting a MOSFET with low $R_{\text{DS(on)}}$ and low gate/drain charge for the Q_1 external MOSFET will help to optimize efficiency.

The MOSFET's current rating must be higher than the input peak current $I_{\text{IN_PEAK}}$. Q_1 must have a V_{DS} rating that exceeds the maximum over-voltage protection (OVP) level configured for the application.

The average and peak current of the diode D_1 must exceed the output average current and input peak current. The diode's maximum reverse voltage rating must exceed the over-voltage protection of the application.

5 ESD Protection

All pins have an ESD protection of $\geq \pm 3500V$ according to the Human Body Model (HBM). The ESD test follows the Human Body Model based on MIL 883-H, Method 3015.8.

6 Pin Configuration and Package

Figure 6.1 ZSLS7025 Pin Assignments

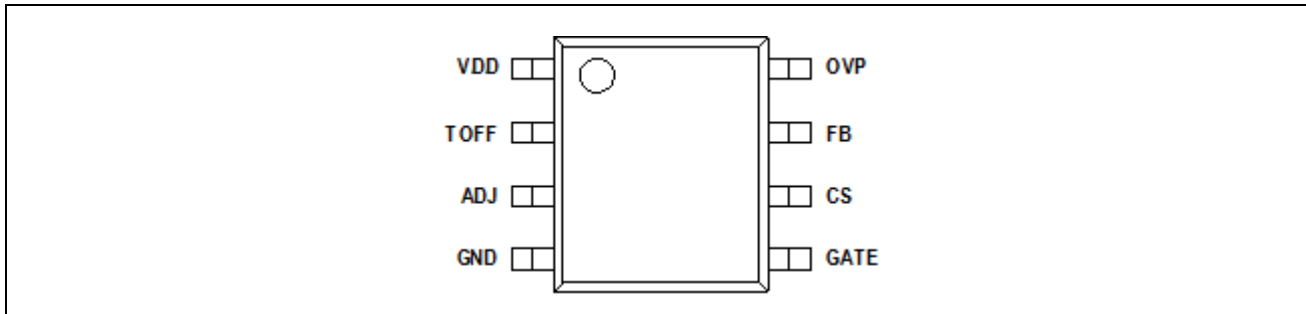
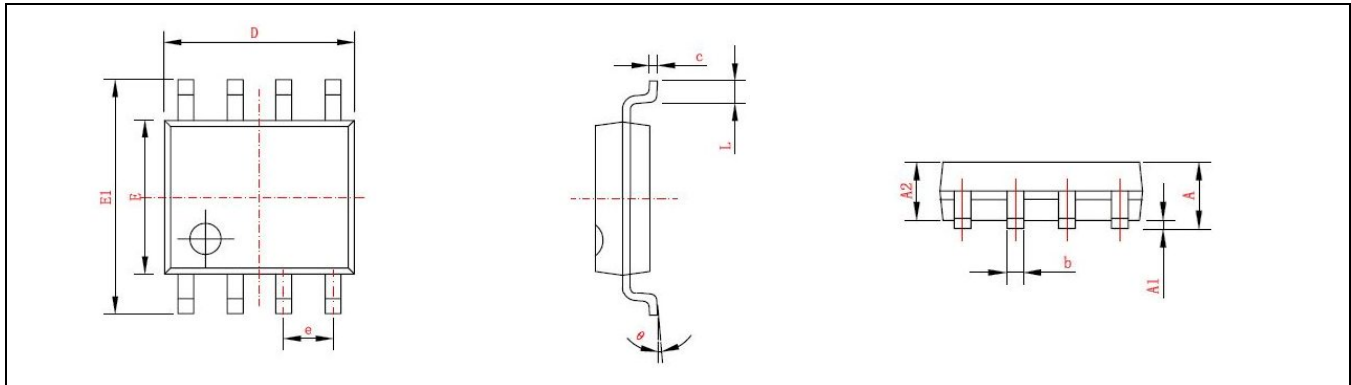

Table 6.1 Pin Description SOP-8

Pin Name	NO.	Description
VDD	1	Positive power supply input pin. Internally clamped at 5V (typical).
TOFF	2	Pin for setting off time. An external resistor, R_{TOFF} , connected to this pin forms an RC discharge path to generate the constant minimum off time of the Q_1 external MOSFET.
ADJ	3	Enable and input peak current control pin. This pin is pulled up to 4.5V internally to set $V_{CS_TH} = 0.24V$ if ADJ is floating. If $V_{ADJ} < 0.5V$, the Q_1 external MOSFET shuts down. If $0.5 \leq V_{ADJ} \leq 2.4V$, $V_{CS_TH} = V_{ADJ}/10$. If $V_{ADJ} > 2.4V$, $V_{CS_TH} = 0.24V$.
GND	4	Ground.
GATE	5	Driver's output for the gate of the Q_1 external MOSFET.
CS	6	Current sense input for the boost, peak-current control loop.
FB	7	Feedback voltage input pin. Used to regulate the current of the LEDs by keeping $V_{FB} = 0.3V$.
OVP	8	Overvoltage protection input pin. If the voltage at OVP exceeds the over-voltage input threshold, V_{OVP_TH} , the GATE output shuts down.

Figure 6.2 SOP-8 Package Dimensions and Pin Assignments



SOP-8 Package Dimensions (mm, except θ)			
A	1.550 ± 0.200	E	3.900 ± 0.100
A1	0.175 ± 0.075	E1	6.000 ± 0.200
A2	1.450 Typical	e	1.270 Typical
b	0.420 ± 0.090	L	0.835 ± 0.435
c	0.214 ± 0.036	θ	4° ± 4°
D	4.900 ± 0.200		

7 Glossary

Term	Description
HB	High Brightness
OTP	Over-Temperature Protection
OVP	Over-Voltage Protection
RS Flip-Flop	Reset-Set Flip-Flop
UVLO	Under-Voltage Lockout

8 Ordering Information

Product Sales Code	Description	Package
ZSLS7025ZI1R	ZSLS7025 – Boost LED Driver	SOP-8 (Tape & Reel)
ZSLS7025KIT-D1	ZSLS7025PCB-D1 Demo Board, 1 ZLED-PCB10, and 5 ZSLS7025 ICs	Kit

9 Document Revision History

Revision	Date	Description
1.00	June 28, 2012	First issue.
	April 20, 2016	Changed to IDT branding.

Notice

1. Descriptions of circuits, software and other related information in this document are provided only to illustrate the operation of semiconductor products and application examples. You are fully responsible for the incorporation or any other use of the circuits, software, and information in the design of your product or system. Renesas Electronics disclaims any and all liability for any losses and damages incurred by you or third parties arising from the use of these circuits, software, or information.
2. Renesas Electronics hereby expressly disclaims any warranties against and liability for infringement or any other claims involving patents, copyrights, or other intellectual property rights of third parties, by or arising from the use of Renesas Electronics products or technical information described in this document, including but not limited to, the product data, drawings, charts, programs, algorithms, and application examples.
3. No license, express, implied or otherwise, is granted hereby under any patents, copyrights or other intellectual property rights of Renesas Electronics or others.
4. You shall not alter, modify, copy, or reverse engineer any Renesas Electronics product, whether in whole or in part. Renesas Electronics disclaims any and all liability for any losses or damages incurred by you or third parties arising from such alteration, modification, copying or reverse engineering.
5. Renesas Electronics products are classified according to the following two quality grades: "Standard" and "High Quality". The intended applications for each Renesas Electronics product depends on the product's quality grade, as indicated below.
 - "Standard": Computers; office equipment; communications equipment; test and measurement equipment; audio and visual equipment; home electronic appliances; machine tools; personal electronic equipment; industrial robots; etc.
 - "High Quality": Transportation equipment (automobiles, trains, ships, etc.); traffic control (traffic lights); large-scale communication equipment; key financial terminal systems; safety control equipment; etc.Unless expressly designated as a high reliability product or a product for harsh environments in a Renesas Electronics data sheet or other Renesas Electronics document, Renesas Electronics products are not intended or authorized for use in products or systems that may pose a direct threat to human life or bodily injury (artificial life support devices or systems; surgical implantations; etc.), or may cause serious property damage (space system; undersea repeaters; nuclear power control systems; aircraft control systems; key plant systems; military equipment; etc.). Renesas Electronics disclaims any and all liability for any damages or losses incurred by you or any third parties arising from the use of any Renesas Electronics product that is inconsistent with any Renesas Electronics data sheet, user's manual or other Renesas Electronics document.
6. When using Renesas Electronics products, refer to the latest product information (data sheets, user's manuals, application notes, "General Notes for Handling and Using Semiconductor Devices" in the reliability handbook, etc.), and ensure that usage conditions are within the ranges specified by Renesas Electronics with respect to maximum ratings, operating power supply voltage range, heat dissipation characteristics, installation, etc. Renesas Electronics disclaims any and all liability for any malfunctions, failure or accident arising out of the use of Renesas Electronics products outside of such specified ranges.
7. Although Renesas Electronics endeavors to improve the quality and reliability of Renesas Electronics products, semiconductor products have specific characteristics, such as the occurrence of failure at a certain rate and malfunctions under certain use conditions. Unless designated as a high reliability product or a product for harsh environments in a Renesas Electronics data sheet or other Renesas Electronics document, Renesas Electronics products are not subject to radiation resistance design. You are responsible for implementing safety measures to guard against the possibility of bodily injury, injury or damage caused by fire, and/or danger to the public in the event of a failure or malfunction of Renesas Electronics products, such as safety design for hardware and software, including but not limited to redundancy, fire control and malfunction prevention, appropriate treatment for aging degradation or any other appropriate measures. Because the evaluation of microcomputer software alone is very difficult and impractical, you are responsible for evaluating the safety of the final products or systems manufactured by you.
8. Please contact a Renesas Electronics sales office for details as to environmental matters such as the environmental compatibility of each Renesas Electronics product. You are responsible for carefully and sufficiently investigating applicable laws and regulations that regulate the inclusion or use of controlled substances, including without limitation, the EU RoHS Directive, and using Renesas Electronics products in compliance with all these applicable laws and regulations. Renesas Electronics disclaims any and all liability for damages or losses occurring as a result of your noncompliance with applicable laws and regulations.
9. Renesas Electronics products and technologies shall not be used for or incorporated into any products or systems whose manufacture, use, or sale is prohibited under any applicable domestic or foreign laws or regulations. You shall comply with any applicable export control laws and regulations promulgated and administered by the governments of any countries asserting jurisdiction over the parties or transactions.
10. It is the responsibility of the buyer or distributor of Renesas Electronics products, or any other party who distributes, disposes of, or otherwise sells or transfers the product to a third party, to notify such third party in advance of the contents and conditions set forth in this document.
11. This document shall not be reprinted, reproduced or duplicated in any form, in whole or in part, without prior written consent of Renesas Electronics.
12. Please contact a Renesas Electronics sales office if you have any questions regarding the information contained in this document or Renesas Electronics products.

(Note1) "Renesas Electronics" as used in this document means Renesas Electronics Corporation and also includes its directly or indirectly controlled subsidiaries.

(Note2) "Renesas Electronics product(s)" means any product developed or manufactured by or for Renesas Electronics.

(Rev.4.0-1 November 2017)

Corporate Headquarters

TOYOSU FORESIA, 3-2-24 Toyosu,
Koto-ku, Tokyo 135-0061, Japan
www.renesas.com

Contact Information

For further information on a product, technology, the most up-to-date version of a document, or your nearest sales office, please visit:
www.renesas.com/contact/

Trademarks

Renesas and the Renesas logo are trademarks of Renesas Electronics Corporation. All trademarks and registered trademarks are the property of their respective owners.