



IDT™ 89HPES16T4G2  
PCI Express® Switch

Preliminary User Manual

January 2013

6024 Silver Creek Valley Road, San Jose, California 95138  
Telephone: (800) 345-7015 • (408) 284-8200 • FAX: (408) 284-2775  
Printed in U.S.A.  
©2013 Integrated Device Technology, Inc.

---

---

#### GENERAL DISCLAIMER

Integrated Device Technology, Inc. reserves the right to make changes to its products or specifications at any time, without notice, in order to improve design or performance and to supply the best possible product. IDT does not assume any responsibility for use of any circuitry described other than the circuitry embodied in an IDT product. The Company makes no representations that circuitry described herein is free from patent infringement or other rights of third parties which may result from its use. No license is granted by implication or otherwise under any patent, patent rights or other rights, of Integrated Device Technology, Inc.

#### CODE DISCLAIMER

Code examples provided by IDT are for illustrative purposes only and should not be relied upon for developing applications. Any use of the code examples below is completely at your own risk. IDT MAKES NO REPRESENTATIONS OR WARRANTIES OF ANY KIND CONCERNING THE NONINFRINGEMENT, QUALITY, SAFETY OR SUITABILITY OF THE CODE, EITHER EXPRESS OR IMPLIED, INCLUDING WITHOUT LIMITATION ANY IMPLIED WARRANTIES OF MERCHANTABILITY, FITNESS FOR A PARTICULAR PURPOSE, OR NON-INFRINGEMENT. FURTHER, IDT MAKES NO REPRESENTATIONS OR WARRANTIES AS TO THE TRUTH, ACCURACY OR COMPLETENESS OF ANY STATEMENTS, INFORMATION OR MATERIALS CONCERNING CODE EXAMPLES CONTAINED IN ANY IDT PUBLICATION OR PUBLIC DISCLOSURE OR THAT IS CONTAINED ON ANY IDT INTERNET SITE. IN NO EVENT WILL IDT BE LIABLE FOR ANY DIRECT, CONSEQUENTIAL, INCIDENTAL, INDIRECT, PUNITIVE OR SPECIAL DAMAGES, HOWEVER THEY MAY ARISE, AND EVEN IF IDT HAS BEEN PREVIOUSLY ADVISED ABOUT THE POSSIBILITY OF SUCH DAMAGES. The code examples also may be subject to United States export control laws and may be subject to the export or import laws of other countries and it is your responsibility to comply with any applicable laws or regulations.

#### LIFE SUPPORT POLICY

Integrated Device Technology's products are not authorized for use as critical components in life support devices or systems unless a specific written agreement pertaining to such intended use is executed between the manufacturer and an officer of IDT.

1. Life support devices or systems are devices or systems which (a) are intended for surgical implant into the body or (b) support or sustain life and whose failure to perform, when properly used in accordance with instructions for use provided in the labeling, can be reasonably expected to result in a significant injury to the user.
2. A critical component is any components of a life support device or system whose failure to perform can be reasonably expected to cause the failure of the life support device or system, or to affect its safety or effectiveness.

IDT, the IDT logo, and Integrated Device Technology are trademarks or registered trademarks of Integrated Device Technology, Inc.

---



## Notes

## Introduction

This user manual includes hardware and software information on the 89HPES16T4G2, a member of IDT's PRECISE™ family of PCI Express® switching solutions offering the next-generation I/O interconnect standard.

### Finding Additional Information

Information not included in this manual such as mechanicals, package pin-outs, and electrical characteristics can be found in the data sheet for this device, which is available from the IDT website ([www.idt.com](http://www.idt.com)) as well as through your local IDT sales representative.

## Content Summary

**Chapter 1, "PES16T4G2 Device Overview,"** provides a complete introduction to the performance capabilities of the 89HPES16T4G2. Included in this chapter is a summary of features for the device as well as a system block diagram and pin description.

**Chapter 2, "Clocking, Reset, and Initialization,"** provides a description of the two differential reference clock inputs that are used internally to generate all of the clocks required by the internal switch logic and the SerDes.

**Chapter 3, "Link Operation,"** describes the operation of the link feature including polarity inversion, link width negotiation, and lane reversal.

**Chapter 4, "General Purpose I/O,"** describes how the 16 General Purpose I/O (GPIO) pins may be individually configured as general purpose inputs, general purpose outputs, or alternate functions.

**Chapter 5, "SMBus Interfaces,"** describes the operation of the 2 SMBus interfaces on the PES16T4G2.

**Chapter 6, "Power Management,"** describes the power management capability structure located in the configuration space of each PCI-PCI bridge in the PES16T4G2.

**Chapter 7, "Hot-Plug and Hot-Swap,"** describes the behavior of the hot-plug and hot-swap features in the PES16T4G2.

**Chapter 8, "Configuration Registers,"** discusses the base addresses, PCI configuration space, and registers associated with the PES16T4G2.

**Chapter 9, "JTAG Boundary Scan,"** discusses an enhanced JTAG interface, including a system logic TAP controller, signal definitions, a test data register, an instruction register, and usage considerations.

## Signal Nomenclature

To avoid confusion when dealing with a mixture of "active-low" and "active-high" signals, the terms assertion and negation are used. The term assert or assertion is used to indicate that a signal is active or true, independent of whether that level is represented by a high or low voltage. The term negate or negation is used to indicate that a signal is inactive or false.

To define the active polarity of a signal, a suffix will be used. Signals ending with an 'N' should be interpreted as being active, or asserted, when at a logic zero (low) level. All other signals (including clocks, buses and select lines) will be interpreted as being active, or asserted when at a logic one (high) level.

To define buses, the most significant bit (MSB) will be on the left and least significant bit (LSB) will be on the right. No leading zeros will be included.

## Notes

Throughout this manual, when describing signal transitions, the following terminology is used. Rising edge indicates a low-to-high (0 to 1) transition. Falling edge indicates a high-to-low (1 to 0) transition. These terms are illustrated in Figure 1.

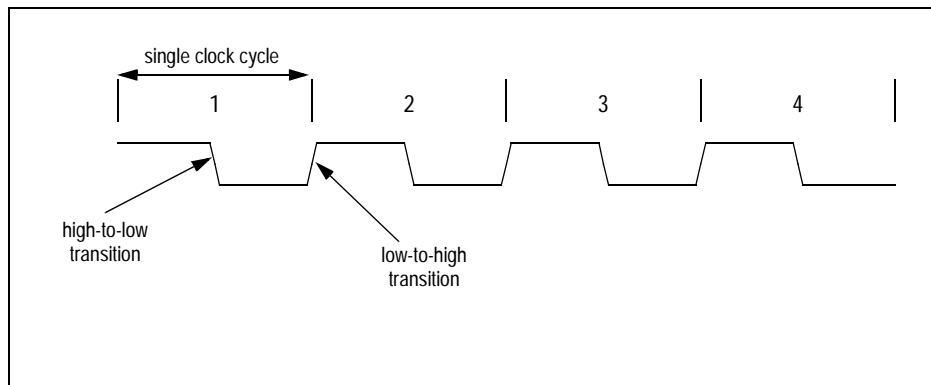

Figure 1 Signal Transitions

## Numeric Representations

To represent numerical values, either decimal, binary, or hexadecimal formats will be used. The binary format is as follows: 0bDDD, where "D" represents either 0 or 1; the hexadecimal format is as follows: 0xDD, where "D" represents the hexadecimal digit(s); otherwise, it is decimal.

The compressed notation ABC[x|y|z]D refers to ABCxD, ABCyD, and ABCzD.

The compressed notation ABC[x..y]D refers to ABCxD, ABC(x+1)D, ABC(x+2)D,... ABCyD.

## Data Units

The following data unit terminology is used in this document.

Term	Words	Bytes	Bits
Byte	1/2	1	8
Word	1	2	16
Doubleword (Dword)	2	4	32
Quadword (Qword)	4	8	64

Table 1 Data Unit Terminology

In quadwords, bit 63 is always the most significant bit and bit 0 is the least significant bit. In doublewords, bit 31 is always the most significant bit and bit 0 is the least significant bit. In words, bit 15 is always the most significant bit and bit 0 is the least significant bit. In bytes, bit 7 is always the most significant bit and bit 0 is the least significant bit.

The ordering of bytes within words is referred to as either "big endian" or "little endian." Big endian systems label byte zero as the most significant (leftmost) byte of a word. Little endian systems label byte zero as the least significant (rightmost) byte of a word. See Figure 2.

## Notes

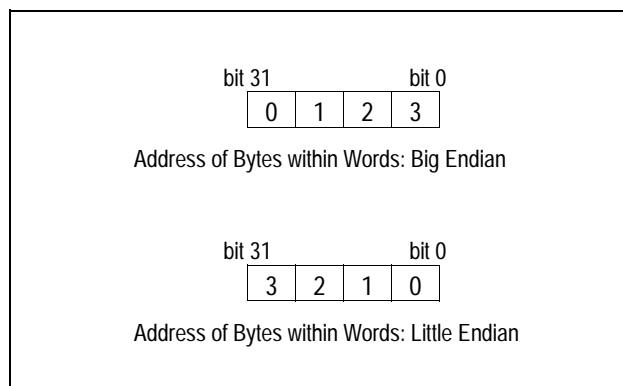

Figure 2 Example of Byte Ordering for “Big Endian” or “Little Endian” System Definition

## Register Terminology

Software in the context of this register terminology refers to modifications made by PCIe root configuration writes to registers made through the slave SMBus interface or serial EEPROM register initialization. See Table 2.

Type	Abbreviation	Description
Hardware Initialized	HWINIT	Register bits are initialized by firmware or hardware mechanisms such as pin strapping or serial EEPROM. (System firmware hardware initialization is only allowed for system integrated devices.) Bits are read-only after initialization and can only be reset (for write-once by firmware) with reset.
Read Only and Clear	RC	Software can read the register/bits with this attribute. Reading the value will automatically cause the register/bit to be reset to zero. Writing to a RC location has no effect.
Read Clear and Write	RCW	Software can read the register/bits with this attribute. Reading the value will automatically cause the register/bits to be reset to zero. Writes cause the register/bits to be modified.
Reserved	Reserved	The value read from a reserved register/bit is undefined. Thus, software must deal correctly with fields that are reserved. On reads, software must use appropriate masks to extract the defined bits and not rely on reserved bits being any particular value. On writes, software must ensure that the values of reserved bit positions are preserved. That is, the values of reserved bit positions must first be read, merged with the new values for other bit positions and then written back.
Read Only	RO	Software can only read registers/bits with this attribute. Contents are hardwired to a constant value or are status bits that may be set and cleared by hardware. Writing to a RO location has no effect.
Read and Write	RW	Software can both read and write bits with this attribute.

Table 2 Register Terminology (Sheet 1 of 2)

## Notes

Type	Abbreviation	Description
Read and Write Clear	RW1C	Software can read and write to registers/bits with this attribute. However, writing a value of zero to a bit with this attribute has no effect. A RW1C bit can only be set to a value of 1 by a hardware event. To clear a RW1C bit (i.e., change its value to zero) a value of one must be written to the location. An RW1C bit is never cleared by hardware.
Read and Write when Unlocked	RWL	Software can read the register/bits with this attribute. Writing to register/bits with this attribute will only cause the value to be modified if the REGUNLOCK bit in the SWCNTL register is set. When the REGUNLOCK bit is cleared, writes are ignored and the register/bits are effectively read-only
Write Transient	WT	The zero is always read from a bit/field of this type. Writing of a one is used to qualify the writing of other bits/fields in the same register.
Zero	Zero	A zero register or bit must be written with a value of zero and returns a value of zero when read.

Table 2 Register Terminology (Sheet 2 of 2)

## Use of Hypertext

In Chapter 8, Tables 8.2 and 8.3 contain register names and page numbers highlighted in blue under the Register Definition column. In pdf files, users can jump from this source table directly to the registers by clicking on the register name in the source table. Each register name in the table is linked directly to the appropriate register in the register section of the chapter. To return to the source table after having jumped to the register section, click on the same register name (in blue) in the register section.

## Reference Documents

PCI Express Base Specification, Revision 1.1, PCI Special Interest Group.

PCI Power Management Interface Specification, Revision 1.1, PCI Special Interest Group.

PCI to PCI Bridge Architecture Specification, Revision 1.2, PCI Special Interest Group.

SMBus Specification, Revision 2.0.

## Revision History

**May 22, 2007:** Initial publication of preliminary user manual.

**June 26, 2007:** In Chapter 8, Configuration Registers, included only 3 registers with addresses in the 0x400-0x600 range. Updated Chapter 3, Link Operation.

**July 11, 2007:** Corrected AERUCS to AERUES in AERCTL register, Chapter 8. Added additional registers to Chapter 8 in the 0x400-0x600 range.

**February 6, 2008:** Added PMETOATIMER register to Chapter 8.

**October 31, 2008:** In Chapter 8, revised description LOSEL field in the PCIELCAP register and LDIS field in the PCIELCTL register.

**September 15, 2010:** In Table 1.9, changed Buffer type for PCI Express from CML to PCIe differential and changed reference clocks to HCSL

**February 22, 2012:** Added paragraph after Table 5.11 to explain use of DWord addresses.

**January 28, 2013:** In Figure 5.8, changed No-ack to Ack between DATALM and DATAUM.



## Notes

### About This Manual

Introduction .....	1
Content Summary .....	1
Signal Nomenclature .....	1
Numeric Representations .....	2
Data Units .....	2
Register Terminology .....	3
Use of Hypertext .....	4
Reference Documents .....	4
Revision History .....	4

### PES16T4G2 Device Overview

Introduction .....	1-1
Features .....	1-1
System Diagram .....	1-2
Logic Diagram .....	1-3
System Identification .....	1-4
Vendor ID .....	1-4
Device ID .....	1-4
Revision ID .....	1-4
JTAG ID .....	1-4
Pin Description .....	1-4
Pin Characteristics .....	1-9
Port Configuration .....	1-10

### Clocking, Reset and Initialization

Clocking .....	2-1
Initialization .....	2-1
Reset .....	2-2
Fundamental Reset .....	2-3
Hot Reset .....	2-5
Upstream Secondary Bus Reset .....	2-6
Downstream Secondary Bus Reset .....	2-6
Downstream Port Reset Outputs .....	2-7
Power Enable Controlled Reset Output .....	2-7
Power Good Controlled Reset Output .....	2-8

### Link Operation

Introduction .....	3-1
Polarity Inversion .....	3-1
Lane Reversal .....	3-1
Link Width Negotiation .....	3-2
Dynamic Link Width Re-Configuration .....	3-2
Background .....	3-2
Dynamic Link Width Re-Configuration Support in the PES16T4G2 .....	3-3
Link Speed Negotiation .....	3-3
Background .....	3-3

## Notes

Link Speed Negotiation in the PES16T4G2 .....	3-4
Software Management of Link Speed .....	3-5
Link Retraining .....	3-6
Slot Power Limit Support .....	3-6
Upstream Port .....	3-6
Downstream Port .....	3-7
Link States .....	3-7
Active State Power Management .....	3-8
Link Status .....	3-8
De-emphasis Negotiation .....	3-8
Low-Swing Transmitter Voltage Mode .....	3-9
<b>General Purpose I/O</b>	
Introduction .....	4-1
GPIO Configuration .....	4-1
GPIO Pin Configured as an Input .....	4-2
GPIO Pin Configured as an Output .....	4-2
GPIO Pin Configured as an Alternate Function .....	4-2
<b>SMBus Interfaces</b>	
Introduction .....	5-1
Master SMBus Interface .....	5-2
Initialization .....	5-2
Serial EEPROM .....	5-2
I/O Expanders .....	5-6
Slave SMBus Interface .....	5-11
Initialization .....	5-11
SMBus Transactions .....	5-12
<b>Power Management</b>	
Introduction .....	6-1
PME Messages .....	6-2
PCI-Express Power Management Fence Protocol .....	6-2
Power Budgeting Capability .....	6-3
<b>Hot-Plug and Hot-Swap</b>	
Hot-Plug .....	7-1
Hot-Plug I/O Expander .....	7-4
Hot-Plug Interrupts and Wake-up .....	7-4
Legacy System Hot-Plug Support .....	7-4
Hot-Swap .....	7-6
<b>Configuration Registers</b>	
Configuration Space Organization .....	8-1
Upstream Port (Port 0) .....	8-3
Downstream Ports .....	8-6
Register Definitions .....	8-10
Type 1 Configuration Header Registers .....	8-10
PCI Express Capability Structure .....	8-19
Power Management Capability Structure .....	8-34
Message Signaled Interrupt Capability Structure .....	8-36
Subsystem ID and Subsystem Vendor ID .....	8-37



## Notes

Extended Configuration Space Access Registers .....	8-38
Advanced Error Reporting (AER) Enhanced Capability .....	8-39
Device Serial Number Enhanced Capability .....	8-45
PCI Express Virtual Channel Capability .....	8-46
Power Budgeting Enhanced Capability .....	8-52
Switch Status and Control Registers .....	8-53
Physical Layer Control and Status Registers .....	8-60
Power Management Control and Status Registers .....	8-61

**JTAG Boundary Scan**

Introduction .....	9-1
Test Access Point .....	9-1
Signal Definitions .....	9-1
Boundary Scan Chain .....	9-3
Test Data Register (DR) .....	9-4
Boundary Scan Registers .....	9-4
Instruction Register (IR) .....	9-6
EXTEST .....	9-6
SAMPLE/PRELOAD .....	9-7
BYPASS .....	9-7
CLAMP .....	9-7
IDCODE .....	9-7
VALIDATE .....	9-8
RESERVED .....	9-8
Usage Considerations .....	9-8

Notes



# List of Tables

## Notes

Table 1.1	PES16T4G2 Device ID .....	1-4
Table 1.2	PES16T4G2 Revision ID .....	1-4
Table 1.3	PCI Express Interface Pins .....	1-4
Table 1.4	SMBus Interface Pins .....	1-5
Table 1.5	General Purpose I/O Pins .....	1-6
Table 1.6	System Pins .....	1-7
Table 1.7	Test Pins .....	1-8
Table 1.8	Power, Ground, and SerDes Resistor Pins .....	1-8
Table 1.9	Pin Characteristics .....	1-9
Table 2.1	Reference Clock Mode Encoding .....	2-1
Table 2.2	Boot Configuration Vector Signals .....	2-2
Table 4.1	General Purpose I/O Pin Alternate Function .....	4-1
Table 4.2	GPIO Pin Configuration .....	4-1
Table 5.1	Serial EEPROM SMBus Address .....	5-2
Table 5.2	PES16T4G2 Compatible Serial EEPROMs .....	5-3
Table 5.3	Serial EEPROM Initialization Errors .....	5-5
Table 5.4	I/O Expander Function Allocation .....	5-6
Table 5.5	I/O Expander Default Output Signal Value .....	5-7
Table 5.6	I/O Expander 0 Signals .....	5-9
Table 5.7	I/O Expander 2 Signals .....	5-10
Table 5.8	I/O Expander 4 Signals .....	5-10
Table 5.9	Slave SMBus Address When a Static Address is Selected .....	5-11
Table 5.10	Slave SMBus Command Code Fields .....	5-12
Table 5.11	CSR Register Read or Write Operation Byte Sequence .....	5-13
Table 5.12	CSR Register Read or Write CMD Field Description .....	5-14
Table 5.13	Serial EEPROM Read or Write Operation Byte Sequence .....	5-14
Table 5.14	Serial EEPROM Read or Write CMD Field Description .....	5-15
Table 6.1	PES16T4G2 Power Management State Transition Diagram .....	6-2
Table 7.1	Downstream Port Hot Plug Signals .....	7-3
Table 8.1	Base Addresses for Port Configuration Space Registers .....	8-1
Table 8.2	Upstream Port 0 Configuration Space Registers .....	8-3
Table 8.3	Downstream Ports 2, 4, 6 Configuration Space Registers .....	8-6
Table 9.1	JTAG Pin Descriptions .....	9-2
Table 9.2	Boundary Scan Chain .....	9-3
Table 9.3	Instructions Supported by PES16T4G2's JTAG Boundary Scan .....	9-6
Table 9.4	System Controller Device Identification Register .....	9-7

Notes



# List of Figures

## Notes

Figure 1.1	PES16T4G2 Architectural Block Diagram .....	1-2
Figure 1.2	PES16T4G2 Logic Diagram .....	1-3
Figure 1.3	PES16T4G2 Port & Device Numbering .....	1-11
Figure 2.1	Fundamental Reset with Serial EEPROM Initialization .....	2-4
Figure 2.2	Fundamental Reset Using RSTHALT to Keep Device in Quasi-Reset State .....	2-5
Figure 2.3	Power Enable Controlled Reset Output Mode Operation .....	2-7
Figure 2.4	Power Good Controlled Reset Output Mode Operation .....	2-8
Figure 3.1	Port Lane Reversal for Maximum Link Width of x4 (MAXLNKWDTH=0x4) .....	3-1
Figure 3.2	Port Lane Reversal for Maximum Link Width of x2 (MAXLNKWDTH=0x2) .....	3-2
Figure 3.3	PES16T4G2 ASPM Link State Transitions .....	3-7
Figure 5.1	SMBus Interface Configuration Examples .....	5-1
Figure 5.2	Single Double Word Initialization Sequence Format .....	5-3
Figure 5.3	Sequential Double Word Initialization Sequence Format .....	5-4
Figure 5.4	Configuration Done Sequence Format .....	5-4
Figure 5.5	Slave SMBus Command Code Format .....	5-12
Figure 5.6	CSR Register Read or Write CMD Field Format .....	5-13
Figure 5.7	Serial EEPROM Read or Write CMD Field Format .....	5-15
Figure 5.8	CSR Register Read Using SMBus Block Write/Read Transactions with PEC Disabled ..	5-16
Figure 5.9	Serial EEPROM Read Using SMBus Block Write/Read Transactions with PEC Disabled ..	5-16
Figure 5.10	CSR Register Write Using SMBus Block Write Transactions with PEC Disabled .....	5-16
Figure 5.11	Serial EEPROM Write Using SMBus Block Write Transactions with PEC Disabled .....	5-17
Figure 5.12	Serial EEPROM Write Using SMBus Block Write Transactions with PEC Enabled .....	5-17
Figure 5.13	CSR Register Read Using SMBus Read and Write Transactions with PEC Disabled .....	5-17
Figure 6.1	PES16T4G2 Power Management State Transition Diagram .....	6-1
Figure 7.1	Hot-Plug on Switch Downstream Slots Application .....	7-1
Figure 7.2	Hot-Plug with Switch on Add-In Card Application .....	7-2
Figure 7.3	Hot-Plug with Carrier Card Application .....	7-2
Figure 7.4	PES16T4G2 Hot-Plug Event Signalling .....	7-5
Figure 8.1	Port Configuration Space Organization .....	8-2
Figure 9.1	Diagram of the JTAG Logic .....	9-1
Figure 9.2	State Diagram of PES16T4G2's TAP Controller .....	9-2
Figure 9.3	Diagram of Observe-only Input Cell .....	9-4
Figure 9.4	Diagram of Output Cell .....	9-5
Figure 9.5	Diagram of Bidirectional Cell .....	9-5
Figure 9.6	Device ID Register Format .....	9-7

Notes



# Register List

## Notes

AERCAP - AER Capabilities (0x100) .....	8-39
AERCEM - AER Correctable Error Mask (0x114) .....	8-44
AERCES - AER Correctable Error Status (0x110) .....	8-43
AERCTL - AER Control (0x118) .....	8-44
AERHL1DW - AER Header Log 1st Doubleword (0x11C) .....	8-45
AERHL2DW - AER Header Log 2nd Doubleword (0x120) .....	8-45
AERHL3DW - AER Header Log 3rd Doubleword (0x124) .....	8-45
AERHL4DW - AER Header Log 4th Doubleword (0x128) .....	8-45
AERUEM - AER Uncorrectable Error Mask (0x108) .....	8-40
AERUES - AER Uncorrectable Error Status (0x104) .....	8-39
AERUESV - AER Uncorrectable Error Severity (0x10C) .....	8-42
BAR0 - Base Address Register 0 (0x010) .....	8-13
BAR1 - Base Address Register 1 (0x014) .....	8-13
BCTL - Bridge Control Register (0x03E) .....	8-18
BIST - Built-in Self Test Register (0x00F) .....	8-13
CAPPTR - Capabilities Pointer Register (0x034) .....	8-17
CCODE - Class Code Register (0x009) .....	8-12
CLS - Cache Line Size Register (0x00C) .....	8-12
DID - Device Identification Register (0x002) .....	8-10
ECFGADDR - Extended Configuration Space Access Address (0x0F8) .....	8-38
ECFGDATA - Extended Configuration Space Access Data (0x0FC) .....	8-38
EEPROMINTF - Serial EEPROM Interface (0x42C) .....	8-58
EROMBASE - Expansion ROM Base Address Register (0x038) .....	8-17
GPECTL - General Purpose Event Control (0x450) .....	8-59
GPESTS - General Purpose Event Status (0x454) .....	8-60
GPIOCFG - General Purpose I/O Configuration (0x41C) .....	8-56
GPIOD - General Purpose I/O Data (0x420) .....	8-56
GPIOFUNC - General Purpose I/O Control Function (0x418) .....	8-56
HDR - Header Type Register (0x00E) .....	8-13
HPCFGCTL - Hot-Plug Configuration Control (0x408) .....	8-55
INTRLINE - Interrupt Line Register (0x03C) .....	8-18
INTRPIN - Interrupt PIN Register (0x03D) .....	8-18
IOBASE - I/O Base Register (0x01C) .....	8-14
IOBASEU - I/O Base Upper Register (0x030) .....	8-17
IOEXPADDR0 - SMBus I/O Expander Address 0 (0x434) .....	8-59
IOEXPADDR1 - SMBus I/O Expander Address 1 (0x438) .....	8-59
IOLIMIT - I/O Limit Register (0x01D) .....	8-14
IOLIMITU - I/O Limit Upper Register (0x032) .....	8-17
MBASE - Memory Base Register (0x020) .....	8-15
MLIMIT - Memory Limit Register (0x022) .....	8-15
MSIADDR - Message Signaled Interrupt Address (0x0D4) .....	8-37
MSICAP - Message Signaled Interrupt Capability and Control (0x0D0) .....	8-36
MSIMDATA - Message Signaled Interrupt Message Data (0x0DC) .....	8-37
MSIUADDR - Message Signaled Interrupt Upper Address (0x0D8) .....	8-37
PBUSN - Primary Bus Number Register (0x018) .....	8-13
PCICMD - PCI Command Register (0x004) .....	8-10
PCIECAP - PCI Express Capability (0x040) .....	8-19
PCIEDCAP - PCI Express Device Capabilities (0x044) .....	8-20
PCIEDCAP2 - PCI Express Device Capabilities 2 (0x064) .....	8-31

## Notes

PCIEDCTL - PCI Express Device Control (0x048).....	8-21
PCIEDCTL2 - PCI Express Device Control 2 (0x068).....	8-31
PCIEDSTS - PCI Express Device Status (0x04A).....	8-22
PCIEDSTS2 - PCI Express Device Status 2 (0x06A).....	8-32
PCIELCAP - PCI Express Link Capabilities (0x04C).....	8-23
PCIELCAP2 - PCI Express Link Capabilities 2 (0x06C).....	8-32
PCIELCTL - PCI Express Link Control (0x050).....	8-24
PCIELCTL2 - PCI Express Link Control 2 (0x070).....	8-32
PCIELSTS - PCI Express Link Status (0x052).....	8-26
PCIELSTS2 - PCI Express Link Status 2 (0x072).....	8-34
PCIESCAP - PCI Express Slot Capabilities (0x054).....	8-27
PCIESCAP2 - PCI Express Slot Capabilities 2 (0x074).....	8-34
PCIESCTL - PCI Express Slot Control (0x058).....	8-29
PCIESCTL2 - PCI Express Slot Control 2 (0x078).....	8-34
PCIESSTS - PCI Express Slot Status (0x05A).....	8-30
PCIESSTS2 - PCI Express Slot Status 2 (0x07A).....	8-34
PCIEVCECAP - PCI Express VC Enhanced Capability Header (0x200).....	8-46
PCISTS - PCI Status Register (0x006).....	8-11
PHYLSTATE0 - Phy Link State 0 (0x534).....	8-61
PLTIMER - Primary Latency Timer (0x00D).....	8-12
PMBASE - Prefetchable Memory Base Register (0x024).....	8-16
PMBASEU - Prefetchable Memory Base Upper Register (0x028).....	8-16
PMCAP - PCI Power Management Capabilities (0x0C0).....	8-34
PMCSR - PCI Power Management Control and Status (0x0C4).....	8-35
PMETOATIMER - PME_TO_Ack Timer (0x708).....	8-61
PMLIMIT - Prefetchable Memory Limit Register (0x026).....	8-16
PMLIMITU - Prefetchable Memory Limit Upper Register (0x02C).....	8-17
PVCCAP1 - Port VC Capability 1 (0x204).....	8-46
PVCCAP2 - Port VC Capability 2 (0x208).....	8-47
PVCCCTL - Port VC Control (0x20C).....	8-47
PVCSTS - Port VC Status (0x20E).....	8-47
PWRBCAP - Power Budgeting Capabilities (0x280).....	8-52
PWRBD - Power Budgeting Data (0x288).....	8-52
PWRBDSEL - Power Budgeting Data Select (0x284).....	8-52
PWRBDV[7:0] - Power Budgeting Data Value [7:0] (0x300 - 0x31C).....	8-53
PWRBPBC - Power Budgeting Power Budget Capability (0x28C).....	8-53
RID - Revision Identification Register (0x008).....	8-12
SBUSN - Secondary Bus Number Register (0x019).....	8-13
SECSTS - Secondary Status Register (0x01E).....	8-15
SERDESCTL - SerDes Control (0x500).....	8-60
SLTIMER - Secondary Latency Timer Register (0x01B).....	8-14
SMBUSCTL - SMBus Control (0x428).....	8-57
SMBUSSTS - SMBus Status (0x424).....	8-57
SNUMCAP - Serial Number Capabilities (0x180).....	8-45
SNUMLDW - Serial Number Lower Doubleword (0x184).....	8-45
SNUMUDW - Serial Number Upper Doubleword (0x188).....	8-46
SSIDSSVID - Subsystem ID and Subsystem Vendor ID (0x0F4).....	8-38
SSIDSSVIDCAP - Subsystem ID and Subsystem Vendor ID Capability (0x0F0).....	8-37
SUBUSN - Subordinate Bus Number Register (0x01A).....	8-14
SWCTL - Switch Control (0x404).....	8-54
SWSTS - Switch Status (0x400).....	8-53
VCR0CAP - VC Resource 0 Capability (0x210).....	8-48
VCR0CTL - VC Resource 0 Control (0x214).....	8-48
VCR0STS - VC Resource 0 Status (0x218).....	8-49
VCR0TBL0 - VC Resource 0 Arbitration Table Entry 0 (0x220).....	8-50



Notes

VCR0TBL1 - VC Resource 0 Arbitration Table Entry 1 (0x224).....8-50  
 VCR0TBL2 - VC Resource 0 Arbitration Table Entry 2 (0x228).....8-51  
 VCR0TBL3 - VC Resource 0 Arbitration Table Entry 3 (0x22C) .....8-51  
 VID - Vendor Identification Register (0x000).....8-10

Notes



# PES16T4G2 Device Overview

## Notes

## Introduction

The 89HPES16T4G2 is a member of IDT's PRECISE™ family of PCI Express® switching solutions. The PES16T4G2 is a 16-lane, 4-port Gen2 peripheral chip that performs PCI Express Base switching with a feature set optimized for high performance applications such as servers, storage, and communications/networking. It provides connectivity and switching functions between a PCI Express upstream port and up to three downstream ports and supports switching between downstream ports.

## Features

### ◆ High Performance PCI Express Switch

- Sixteen 5 Gbps Gen2 PCI Express lanes
- Four switch ports
  - One x4 upstream port
  - Three x4 downstream ports
- Low latency cut-through switch architecture
- Support for Max Payload Size up to 2048 bytes
- One virtual channel
- Eight traffic classes
- PCI Express Base Specification Revision 2.0 compliant

### ◆ Flexible Architecture with Numerous Configuration Options

- Automatic per port link width negotiation to x4, x2 or x1
- Automatic lane reversal on all ports
- Automatic polarity inversion
- Ability to load device configuration from serial EEPROM

### ◆ Legacy Support

- PCI compatible INTx emulation
- Bus locking

### ◆ Highly Integrated Solution

- Incorporates on-chip internal memory for packet buffering and queueing
- Integrates sixteen 5 Gbps embedded SerDes with 8b/10b encoder/decoder (no separate transceivers needed)
  - Receive equalization (RxEQ)

### ◆ Reliability, Availability, and Serviceability (RAS) Features

- Internal end-to-end parity protection on all TLPs ensures data integrity even in systems that do not implement end-to-end CRC (ECRC)
- Supports ECRC and Advanced Error Reporting
- Supports PCI Express Native Hot-Plug, Hot-Swap capable I/O
- Compatible with Hot-Plug I/O expanders used on PC motherboards
- Supports Hot-Swap

### ◆ Power Management

- Utilizes advanced low-power design techniques to achieve low typical power consumption
- Support PCI Express Power Management Interface specification (PCI-PM 1.2)
- Supports PCI Express Active State Power Management (ASPM) link state
- Supports PCI Express Power Budgeting Capability
- Supports the optional PCI Express SerDes Transmit Low-Swing Voltage Mode
- Unused SerDes are disabled and can be powered-off

- ◆ **Testability and Debug Features**
  - Built in Pseudo-Random Bit Stream (PRBS) generator
  - Numerous SerDes test modes
  - Ability to read and write any internal register via the SMBus
  - Ability to bypass link training and force any link into any mode
  - Provides statistics and performance counters
- ◆ **Sixteen General Purpose Input/Output Pins**
  - Each pin may be individually configured as an input or output
  - Each pin may be individually configured as an interrupt input
  - Some pins have selectable alternate functions
- ◆ **Packaged in a 23mm x 23mm, 288-ball BGA with 1mm ball spacing**

## System Diagram

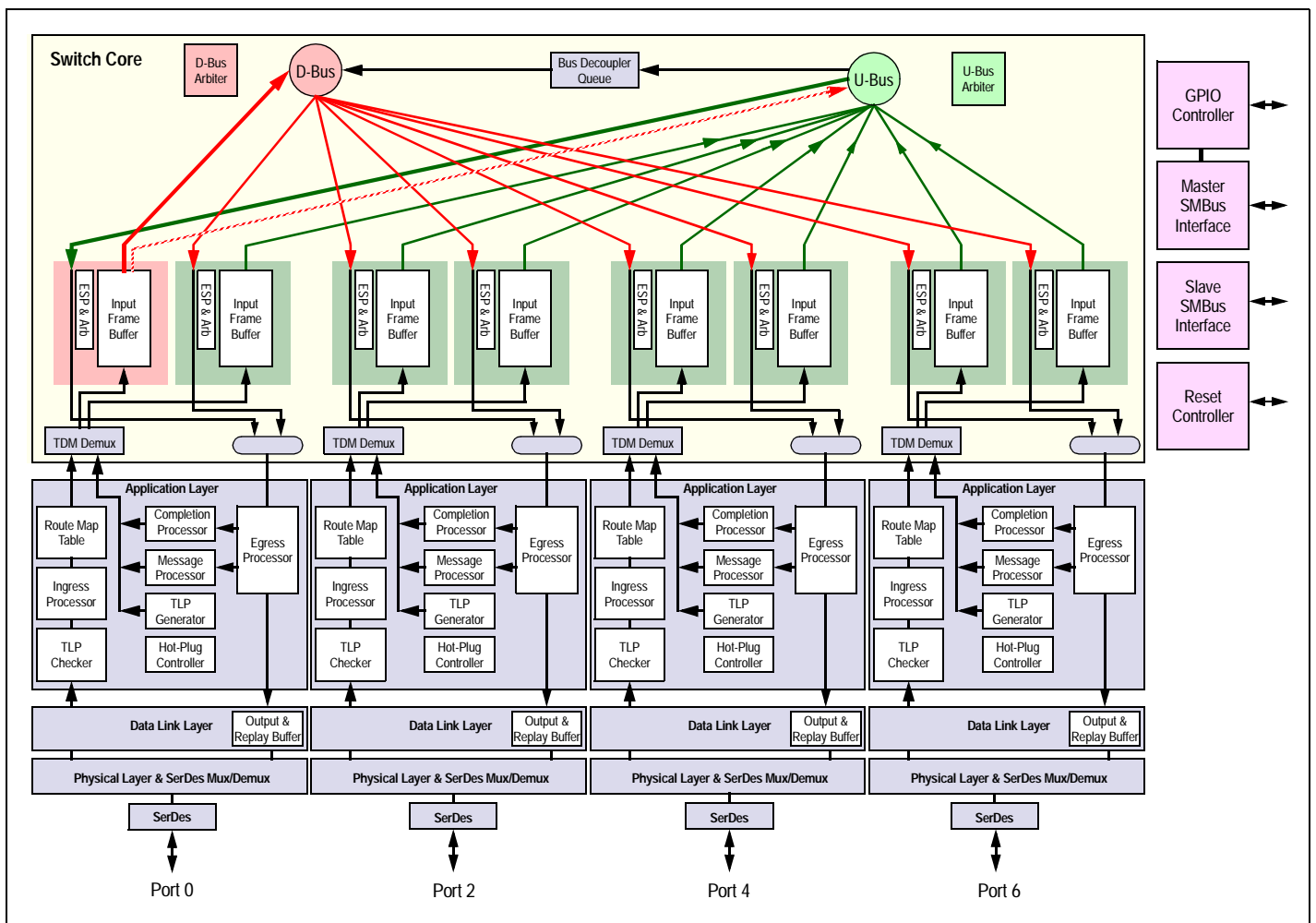

Figure 1.1 PES16T4G2 Architectural Block Diagram

# Logic Diagram

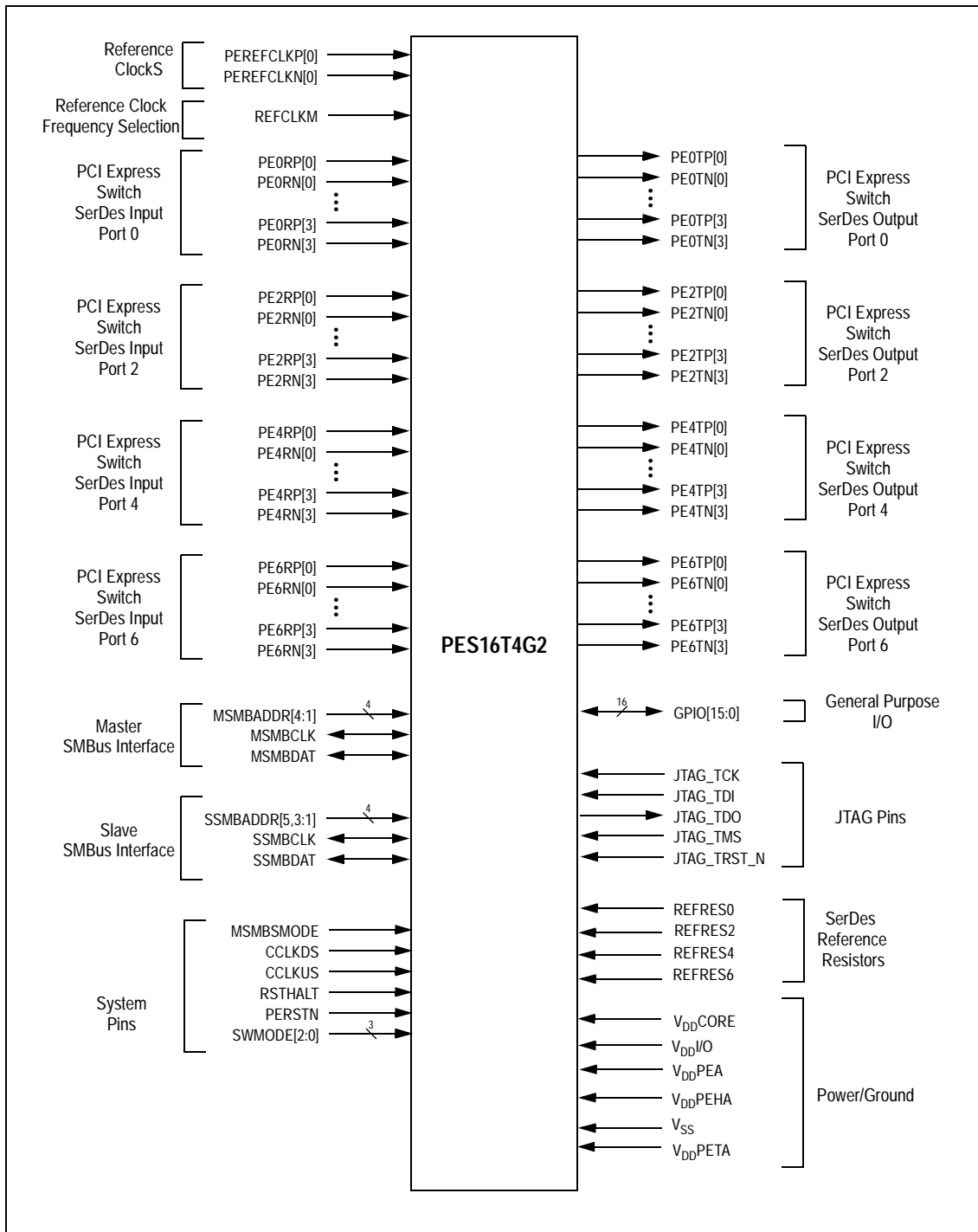

Figure 1.2 PES16T4G2 Logic Diagram

## Notes

## System Identification

## Vendor ID

All vendor ID fields in the device are hardwired to 0x111D which corresponds to Integrated Device Technology, Inc.

## Device ID

The PES16T4G2 device ID is shown in Table 1.1.

PCIe Device	Device ID
0x0	0x8060

Table 1.1 PES16T4G2 Device ID

## Revision ID

The PES16T4G2 revision ID is shown in Table 1.2.

Revision ID	Description
0x0	Corresponds to ZA silicon
0x1	Corresponds to ZB silicon

Table 1.2 PES16T4G2 Revision ID

## JTAG ID

The JTAG ID is:

- Version: Same value as Revision ID. See Table 1.2
- Part number: Same value as base Device ID. See Table 1.1.
- Manufacturer ID: 0x33
- LSB: 0x1

## Pin Description

The following tables list the functions of the pins provided on the PES16T4G2. Some of the functions listed may be multiplexed onto the same pin. The active polarity of a signal is defined using a suffix. Signals ending with an "N" are defined as being active, or asserted, when at a logic zero (low) level. All other signals (including clocks, buses, and select lines) will be interpreted as being active, or asserted, when at a logic one (high) level.

**Note:** In the PES16T4G2, the three downstream ports are labeled port 2, port 4, and port 6.

Signal	Type	Name/Description
PEORP[3:0] PEORN[3:0]	I	<b>PCI Express Port 0 Serial Data Receive.</b> Differential PCI Express receive pairs for port 0. Port 0 is the upstream port.
PE0TP[3:0] PE0TN[3:0]	O	<b>PCI Express Port 0 Serial Data Transmit.</b> Differential PCI Express transmit pairs for port 0. Port 0 is the upstream port.
PE2RP[3:0] PE2RN[3:0]	I	<b>PCI Express Port 2 Serial Data Receive.</b> Differential PCI Express receive pairs for port 2.

Table 1.3 PCI Express Interface Pins (Part 1 of 2)

## Notes

Signal	Type	Name/Description
PE2TP[3:0] PE2TN[3:0]	O	<b>PCI Express Port 2 Serial Data Transmit.</b> Differential PCI Express transmit pairs for port 2.
PE4RP[3:0] PE4RN[3:0]	I	<b>PCI Express Port 4 Serial Data Receive.</b> Differential PCI Express receive pairs for port 4.
PE4TP[3:0] PE4TN[3:0]	O	<b>PCI Express Port 4 Serial Data Transmit.</b> Differential PCI Express transmit pairs for port 4.
PE6RP[3:0] PE6RN[3:0]	I	<b>PCI Express Port 6 Serial Data Receive.</b> Differential PCI Express receive pairs for port 6.
PE6TP[3:0] PE6TN[3:0]	O	<b>PCI Express Port 6 Serial Data Transmit.</b> Differential PCI Express transmit pairs for port 6.
PEREFCLKP[0] PEREFCLKN[0]	I	<b>PCI Express Reference Clock.</b> Differential reference clock pair input. This clock is used as the reference clock by on-chip PLLs to generate the clocks required for the system logic and on-chip SerDes. The frequency of the differential reference clock is determined by the REFCLKM signal.
REFCLKM	I	<b>PCI Express Reference Clock Mode Select.</b> This signal selects the frequency of the reference clock input. 0x0 - 100 MHz 0x1 - 125 MHz This pin should be static and not change following the negation of PERSTN.

Table 1.3 PCI Express Interface Pins (Part 2 of 2)

Signal	Type	Name/Description
MSMBADDR[4:1]	I	<b>Master SMBus Address.</b> These pins determine the SMBus address of the serial EEPROM from which configuration information is loaded.
MSMBCLK	I/O	<b>Master SMBus Clock.</b> This bidirectional signal is used to synchronize transfers on the master SMBus.
MSMBDAT	I/O	<b>Master SMBus Data.</b> This bidirectional signal is used for data on the master SMBus.
SSMBADDR[5,3:1]	I	<b>Slave SMBus Address.</b> These pins determine the SMBus address to which the slave SMBus interface responds.
SSMBCLK	I/O	<b>Slave SMBus Clock.</b> This bidirectional signal is used to synchronize transfers on the slave SMBus.
SSMBDAT	I/O	<b>Slave SMBus Data.</b> This bidirectional signal is used for data on the slave SMBus.

Table 1.4 SMBus Interface Pins

## Notes

Signal	Type	Name/Description
GPIO[0]	I/O	<b>General Purpose I/O.</b> This pin can be configured as a general purpose I/O pin. Alternate function pin name: P2RSTN Alternate function pin type: Output Alternate function: Reset output for downstream port 2.
GPIO[1]	I/O	<b>General Purpose I/O.</b> This pin can be configured as a general purpose I/O pin. Alternate function pin name: P4RSTN Alternate function pin type: Output Alternate function: Reset output for downstream port 4.
GPIO[2]	I/O	<b>General Purpose I/O.</b> This pin can be configured as a general purpose I/O pin. Alternate function pin name: IOEXPINTN0 Alternate function pin type: Input Alternate function: I/O expander interrupt 0 input.
GPIO[3]	I/O	<b>General Purpose I/O.</b> This pin can be configured as a general purpose I/O pin.
GPIO[4]	I/O	<b>General Purpose I/O.</b> This pin can be configured as a general purpose I/O pin. Alternate function pin name: IOEXPINTN2 Alternate function pin type: Input Alternate function: I/O Expander interrupt 2 input
GPIO[5]	I/O	<b>General Purpose I/O.</b> This pin can be configured as a general purpose I/O pin.
GPIO[6]	I/O	<b>General Purpose I/O.</b> This pin can be configured as a general purpose I/O pin.
GPIO[7]	I/O	<b>General Purpose I/O.</b> This pin can be configured as a general purpose I/O pin. Alternate function pin name: GPEN Alternate function pin type: Output Alternate function: General Purpose Event (GPE) output
GPIO[8]	I/O	<b>General Purpose I/O.</b> This pin can be configured as a general purpose I/O pin.
GPIO[9]	I/O	<b>General Purpose I/O.</b> This pin can be configured as a general purpose I/O pin.
GPIO[10]	I/O	<b>General Purpose I/O.</b> This pin can be configured as a general purpose I/O pin.
GPIO[11]	I/O	<b>General Purpose I/O.</b> This pin can be configured as a general purpose I/O pin. Alternate function pin name: P6RSTN Alternate function pin type: Output Alternate function: Reset output for downstream port 6.
GPIO[12]	I/O	<b>General Purpose I/O.</b> This pin can be configured as a general purpose I/O pin.

Table 1.5 General Purpose I/O Pins (Part 1 of 2)



## Notes

Signal	Type	Name/Description
GPIO[13]	I/O	<b>General Purpose I/O.</b> This pin can be configured as a general purpose I/O pin.
GPIO[14]	I/O	<b>General Purpose I/O.</b> This pin can be configured as a general purpose I/O pin.
GPIO[15]	I/O	<b>General Purpose I/O.</b> This pin can be configured as a general purpose I/O pin.

Table 1.5 General Purpose I/O Pins (Part 2 of 2)

Signal	Type	Name/Description
CCLKDS	I	<b>Common Clock Downstream.</b> The assertion of this pin indicates that all downstream ports are using the same clock source as that provided to downstream devices. This bit is used as the initial value of the Slot Clock Configuration bit in all of the Link Status Registers for downstream ports. The value may be overridden by modifying the SCLK bit in each downstream port's PCIELSTS register.
CCLKUS	I	<b>Common Clock Upstream.</b> The assertion of this pin indicates that the upstream port is using the same clock source as the upstream device. This bit is used as the initial value of the Slot Clock Configuration bit in the Link Status Register for the upstream port. The value may be overridden by modifying the SCLK bit in the P0_PCIELSTS register.
MSMBSMODE	I	<b>Master SMBus Slow Mode.</b> The assertion of this pin indicates that the master SMBus should operate at 100 KHz instead of 400 KHz. This value may not be overridden.
PERSTN	I	<b>Fundamental Reset.</b> Assertion of this signal resets all logic inside PES16T4G2 and initiates a PCI Express fundamental reset.
RSTHALT	I	<b>Reset Halt.</b> When this signal is asserted during a PCI Express fundamental reset, PES16T4G2 executes the reset procedure and remains in a reset state with the Master and Slave SMBuses active. This allows software to read and write registers internal to the device before normal device operation begins. The device exits the reset state when the RSTHALT bit is cleared in the SWCTL register by an SMBus master.
SWMODE[2:0]	I	<b>Switch Mode.</b> These configuration pins determine the PES16T4G2 switch operating mode. 0x0 - Normal switch mode 0x1 - Normal switch mode with Serial EEPROM initialization 0x2 - through 0x7 Reserved These pins should be static and not change following the negation of PERSTN.

Table 1.6 System Pins

## Notes

Signal	Type	Name/Description
JTAG_TCK	I	<b>JTAG Clock.</b> This is an input test clock used to clock the shifting of data into or out of the boundary scan logic or JTAG Controller. JTAG_TCK is independent of the system clock with a nominal 50% duty cycle.
JTAG_TDI	I	<b>JTAG Data Input.</b> This is the serial data input to the boundary scan logic or JTAG Controller.
JTAG_TDO	O	<b>JTAG Data Output.</b> This is the serial data shifted out from the boundary scan logic or JTAG Controller. When no data is being shifted out, this signal is tri-stated.
JTAG_TMS	I	<b>JTAG Mode.</b> The value on this signal controls the test mode select of the boundary scan logic or JTAG Controller.
JTAG_TRST_N	I	<b>JTAG Reset.</b> This active low signal asynchronously resets the boundary scan logic and JTAG TAP Controller. An external pull-up on the board is recommended to meet the JTAG specification in cases where the tester can access this signal. However, for systems running in functional mode, one of the following should occur: <ul style="list-style-type: none"> <li>1) actively drive this signal low with control logic</li> <li>2) statically drive this signal low with an external pull-down on the board</li> </ul>

Table 1.7 Test Pins

Signal	Type	Name/Description
REFRES0	I/O	<b>Port 0 External Reference Resistor.</b> Provides a reference for the Port 0 SerDes bias currents and PLL calibration circuitry. A 3 kOhm +/- 1% resistor should be connected from this pin to ground.
REFRES2	I/O	<b>Port 2 External Reference Resistor.</b> Provides a reference for the Port 2 SerDes bias currents and PLL calibration circuitry. A 3 kOhm +/- 1% resistor should be connected from this pin to ground.
REFRES4	I/O	<b>Port 4 External Reference Resistor.</b> Provides a reference for the Port 4 SerDes bias currents and PLL calibration circuitry. A 3 kOhm +/- 1% resistor should be connected from this pin to ground.
REFRES6	I/O	<b>Port 6 External Reference Resistor.</b> Provides a reference for the Port 6 SerDes bias currents and PLL calibration circuitry. A 3 kOhm +/- 1% resistor should be connected from this pin to ground.
V <sub>DD</sub> CORE	I	<b>Core V<sub>DD</sub>.</b> Power supply for core logic.
V <sub>DD</sub> I/O	I	<b>I/O V<sub>DD</sub>.</b> LVTTTL I/O buffer power supply.
V <sub>DD</sub> PEA	I	<b>PCI Express Analog Power.</b> Serdes analog power supply (1.0V).
V <sub>DD</sub> PEHA	I	<b>PCI Express Analog High Power.</b> Serdes analog power supply (2.5V).
V <sub>DD</sub> PETA	I	<b>PCI Express Transmitter Analog Voltage.</b> Serdes transmitter analog power supply (1.0V).
V <sub>SS</sub>	I	<b>Ground.</b>

Table 1.8 Power, Ground, and SerDes Resistor Pins

## Notes

## Pin Characteristics

**Note:** Some input pads of the PES16T4G2 do not contain internal pull-ups or pull-downs. Unused inputs should be tied off to appropriate levels. This is especially critical for unused control signal inputs which, if left floating, could adversely affect operation. Also, any input pin left floating can cause a slight increase in power consumption.

Function	Pin Name	Type	Buffer	I/O Type	Internal Resistor <sup>1</sup>	Notes
PCI Express Interface	PE0RN[3:0]	I	PCIe differential <sup>2</sup>	Serial Link		
	PE0RP[3:0]	I				
	PE0TN[3:0]	O				
	PE0TP[3:0]	O				
	PE2RN[3:0]	I				
	PE2RP[3:0]	I				
	PE2TN[3:0]	O				
	PE2TP[3:0]	O				
	PE4RN[3:0]	I				
	PE4RP[3:0]	I				
	PE4TN[3:0]	O				
	PE4TP[3:0]	O				
	PE6RN[3:0]	I				
	PE6RP[3:0]	I				
	PE6TN[3:0]	O				
	PE6TP[3:0]	O				
	PEREFCLKN	I	HCSL	Diff. Clock Input		Refer to Table Table 9 in the PES16T4G2 Data Sheet
	PEREFCLKP	I				
		REFCLKM	I	LVTTTL	Input	pull-down
SMBus	MSMBADDR[4:1]	I	LVTTTL	Input	pull-up	
	MSMBCLK	I/O		STI <sup>3</sup>		pull-up on board
	MSMBDAT	I/O		Input		pull-up on board
	SSMBADDR[5,3:1]	I		Input	pull-up	
	SSMBCLK	I/O		STI		pull-up on board
	SSMBDAT	I/O		STI		pull-up on board
General Purpose I/O	GPIO[15:0]	I/O	LVTTTL	STI, High Drive	pull-up	
System Pins	CCLKDS	I	LVTTTL	Input	pull-up	
	CCLKUS	I		Input	pull-up	
	MSMBSMODE	I		Input	pull-down	
	PERSTN	I		STI		
	RSTHALT	I		Input	pull-down	
	SWMODE[2:0]	I		Input	pull-down	

Table 1.9 Pin Characteristics (Part 1 of 2)

## Notes

Function	Pin Name	Type	Buffer	I/O Type	Internal Resistor <sup>1</sup>	Notes
EJTAG / JTAG	JTAG_TCK	I	LVTTTL	STI	pull-up	
	JTAG_TDI	I		STI	pull-up	
	JTAG_TDO	O				
	JTAG_TMS	I		STI	pull-up	
	JTAG_TRST_N	I		STI	pull-up	
SERDES Reference Resistors	REFRES0	I/O	Analog			
	REFRES2	I/O				
	REFRES4	I/O				
	REFRES6	I/O				

Table 1.9 Pin Characteristics (Part 2 of 2)

<sup>1</sup> Internal resistor values under typical operating conditions are 54K  $\Omega$  for pull-up and 251K  $\Omega$  for pull-down.

<sup>2</sup> All receiver pins set the DC common mode voltage to ground. All transmitters must be AC coupled to the media.

<sup>3</sup> Schmitt Trigger Input (STI).

## Port Configuration

The PES16T4G2 contains a total of four ports labeled 0, 2, 4, and 6. Port 0 is always the upstream port. Ports 2, 4, and 6 are always downstream ports. All ports can operate at a maximum link width of x4, and all ports support both 2.5 Gbps and 5.0 Gbps (Gen2).

Per the PCIe specification, each switch port corresponds to a virtual PCI-PCI bridge device. In the PES16T4G2, device numbering follows port numbering. Therefore, Port 0 corresponds to Device 0 on the upstream bus. Port 2 corresponds to Device 2 on the PES16T4G2's virtual PCI bus. Similarly, Port 4 corresponds to Device 4 and Port 6 corresponds to Device 6.

Configuration read or write transactions to a non-existent device on the PES16T4G2's virtual PCI bus (i.e., Device 0, 1, 3, 5, etc.) are treated by the upstream port (port 0) as an unsupported request (i.e., the device does not exist). Additionally, SMBus accesses to configuration registers of a non-existent device have an undefined effect.

Figure 1.3 illustrates a diagram of Whitney with four x4 ports. The figure shows port and device numbering.

Notes

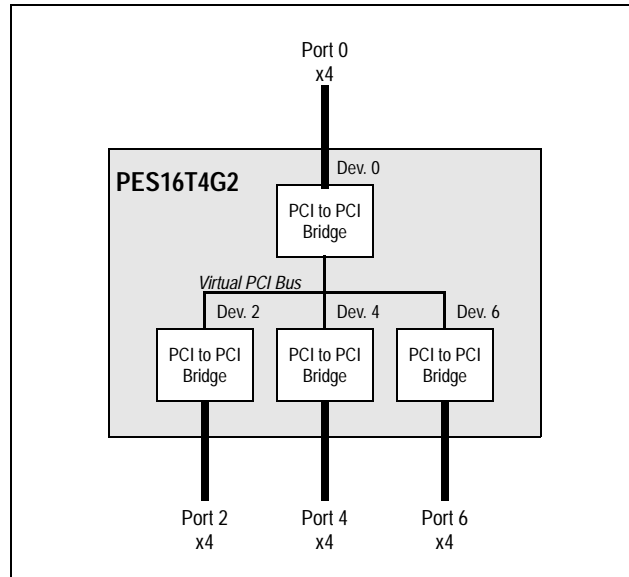

Figure 1.3 PES16T4G2 Port & Device Numbering

Notes



# Clocking, Reset and Initialization

## Notes

### Clocking

The PES16T4G2 has a single differential reference clock input (PEREFCLKP[0]/PEREFCLKN[0]) that is used internally to generate all of the clocks required by the internal switch logic and the SerDes. The frequency of the reference clock inputs may be selected by the Reference Clock Mode Select (REFCLKM) input (see Table 2.1). All reference clock inputs must have the same frequency, as selected by REFCLKM.

REFCLKM	Description
0	100 MHz reference clock input.
1	125 MHz reference clock input.

Table 2.1 Reference Clock Mode Encoding

Each PES16T4G2 port has an associated PLL. The reference clock differential inputs feed the on-chip PLLs (one PLL per SerDes quad). Each PLL generates a 5.0 GHz internal SerDes clock which is used by the four SerDes lanes in a SerDes quad. The PLL also produces a 250 MHz core clock, named PCLK. The 250 MHz PCLK output from the upstream port (i.e., Port 0) is used as the system clock for internal switch logic. When the switch is placed in PLL Bypass test mode via the SWMODE pins, the 250 MHz clock generated by the PLL is bypassed and the reference clock input on PEREFCLKP[0]/PEREFCLKN[0] is used for the core logic.

### Initialization

A boot configuration vector consisting of the signals listed in Table 2.2 is sampled by the PES16T4G2 during a Fundamental Reset when PERSTN is negated. The boot configuration vector defines essential parameters for switch operation.

Since the boot configuration vector is sampled only during a Fundamental Reset sequence, the value of signals which make up the boot configuration vector is ignored during other times and their state outside of a Fundamental Reset has no effect on the operation of the PES16T4G2. While basic switch operation may be configured using signals in the boot configuration vector, advanced switch features require configuration via an external serial EEPROM. The external serial EEPROM allows modification of any bit in any software visible register. See Chapter 5 for more information on the serial EEPROM.

The external serial EEPROM and slave SMBus interface may be used to override the function of some of the signals in the boot configuration vector during a Fundamental Reset. The signals that may be overridden are noted in Table 2.2. The state of all of the boot configuration signals in Table 2.2 sampled during the most recent Fundamental Reset may be determined by reading the SWSTS register.

## Notes

Signal	May Be Overridden	Description
CCLKDS	Y	<b>Common Clock Downstream.</b> The assertion of this pin indicates that all downstream ports are using the same clock source as that provided to downstream devices. This pin is used as the initial value of the Slot Clock Configuration bit in all of the Link Status Registers for downstream ports. The value may be overridden by modifying the SCLK bit in the downstream port's PCIELSTS register.
CCLKUS	Y	<b>Common Clock Upstream.</b> The assertion of this pin indicates that the upstream port is using the same clock source as the upstream device. This pin is used as the initial value of the Slot Clock Configuration bit in the Link Status Register for the upstream port. The value may be overridden by modifying the SCLK bit in the downstream port's PCIELSTS register.
MSMBSMODE	N	<b>Master SMBus Slow Mode.</b> The assertion of this pin indicates that the master SMBus should operate at 100 KHz instead of 400 KHz.
REFCLKM	N	<b>PCI Express Reference Clock Mode Select.</b> This signal selects the frequency of the reference clock input. 0x0 - 100 MHz 0x1 - 125 MHz
RSTHALT	Y	<b>Reset Halt.</b> When this signal is asserted during a PCI Express Fundamental Reset, the PES16T4G2 executes the reset procedure and remains in a reset state with the Master and Slave SMBuses active. This allows software to read and write registers internal to the device before normal device operation begins. The device exits the reset state when the RSTHALT bit is cleared in the SWCTL register through the SMBus. The value may be overridden by modifying the RSTHALT bit in the SWCTL register.
SWMODE[2:0]	N	<b>Switch Mode.</b> These configuration pins determine the PES16T4G2 switch operating mode. 0x0 - Normal Switch Mode 0x1 - Normal Switch Mode with Serial EEPROM Initialization 0x2 through 0x7 - Reserved

Table 2.2 Boot Configuration Vector Signals

## Reset

The PES16T4G2 defines four Conventional Reset categories: Fundamental reset, Hot Reset, Upstream Secondary Bus Hot-Reset, and Downstream Secondary Bus Hot-Reset.

- A Fundamental Reset causes all logic in the PES16T4G2 to be returned to an initial state.
- A Hot Reset causes all logic in the PES16T4G2 to be returned to an initial state, but does not cause the state of register fields denoted as "sticky" to be modified.
- An Upstream Secondary Bus Reset causes all devices on the virtual PCI bus to be hot reset except the upstream port (i.e., upstream PCI to PCI bridge).
- A Downstream Secondary Bus Reset causes a hot reset to be propagated on the corresponding external secondary bus link.

There are two sub-categories of Fundamental Reset: Cold reset and Warm reset. A Cold Reset occurs following a device being powered on and assertion of PERSTN. A Warm Reset is a Fundamental Reset that occurs without removal of power.



## Notes

## Fundamental Reset

A Fundamental Reset may be initiated by any of the following conditions:

- A cold reset initiated by a power-on and the assertion of the PCI Express Reset (PERSTN) input pin.
- A warm reset initiated by the assertion of the PCI Express Reset (PERSTN) input pin while power is on.
- A warm reset initiated by the writing of a one to the Fundamental Reset (FRST) bit in the Switch Control (SWCTL) register.

When configured to operate in normal mode, the following reset sequence is executed.

1. Wait for the Fundamental Reset condition to clear (e.g., negation of PERSTN). Note that PERSTN must be asserted for at least 100 ms ( $T_{pvperl}$ ) after the PES16T4G2 power supplies are stable, and 100 $\mu$ s ( $T_{perst-clk}$ ) after the reference clock input is stable.
2. On negation of PERSTN, sample the boot configuration signals listed in Table 2.2. If PERSTN was not asserted, use the previously sampled boot configuration signal values (e.g., when a Fundamental Reset is the result of setting the Fundamental Reset (FRST) bit in the Switch Control (SWCTL) register).
  - Examine the state of the sampled SWMODE[2:0] signals to determine the switch operating mode.
3. The PLL and SerDes are initialized (i.e., PLL/CDR reset and lock).
4. Link training begins. While link training is in progress, proceed to step 5.
5. If the Reset Halt (RSTHALT) pin is asserted, the RSTHALT bit in the SWSTS register is set.
6. If the switch operating mode is not a test mode, then the reset signal to the PCI Express stacks and associated logic is negated but they are held in a quasi-reset state in which the following actions occur.
  - All links enter an active link training state within 20 ms of the clearing of the Fundamental Reset condition.
  - Within 100 ms of the clearing of the Fundamental Reset condition, all of the stacks are able to process configuration transactions and respond to these transactions with a configuration request retry status completion. All other transactions are ignored.
7. The master SMBus operating frequency is determined.
  - The state of the MSMBSMODE signal is examined. If it is asserted, then the master SMBus is initialized to operate at 100 KHz rather than 400 KHz.
8. The slave SMBus is taken out of reset and initialized. The slave SMBus address specified by the SSMBADDR[5,3:1] pins is used.
9. The master SMBus is taken out of reset and initialized.
10. If the selected switch operating mode is one that requires initialization from the serial EEPROM, then the contents of the serial EEPROM are read and the appropriate PES16T4G2 registers are updated.
  - If a one is written by the serial EEPROM to the Full Link Retrain (FLRET) bit in any Phy Link State 0 (PHYLSTATE0) register, then link retraining is initiated on the corresponding port using the current link parameters.
  - If an error is detected during loading of the serial EEPROM, then loading of the serial EEPROM is aborted and the RSTHALT bit is set in the SWCTL register. Error information is recorded in the SMBUSSTS register.
  - When serial EEPROM initialization completes or when an error is detected, the EEPROM Done (EEPROMDONE) bit in the SMBUSSTS register is set.
  - If the RSTHALT bit is set in the SWCTL register, proceed to step 11. Else, proceed to step 12.
11. If the Reset Halt (RSTHALT) bit is set in the SWCTL register, all of the logic is held in a reset state except the master and slave SMBuses, the control/status registers, and the stacks which continue to be held in a quasi-reset state and respond to configuration transactions with a retry. The device

Notes

remains in this state until the RSTHALT bit is cleared via the slave SMBus. In this mode, an external agent may read and write any internal control and status registers and may access the external serial EEPROM via the EEPROMINTF register.

12. Normal device operation begins.

The PCIe 2.0 specification indicates that a device must respond to Configuration Request transactions within 100 ms from the end of Conventional Reset (cold, warm, or hot). Additionally, the PCIe specification indicates that a device must respond to Configuration Requests with a Successful Completion within 1.0 second after Conventional Reset of a device. The reset sequence above guarantees that the PES16T4G2 will be ready to respond successfully to configuration request within the 1.0 second period as long as the serial EEPROM initialization process completes within 200 ms. During EEPROM initialization, the PES16T4G2 responds to a Configuration Request with Configuration-Request-Retry-Status Completion. Under normal circumstances, 200 ms is more than adequate to initialize registers in the device even with a Master SMBus operating frequency of 100 KHz.

Serial EEPROM initialization may cause writes to register fields that initiate side effects such as link retraining. These side effects are initiated at the point at which the write occurs. Therefore, serial EEPROM initialization should be structured in a manner so as to ensure proper configuration prior to initiation of these side effects.

A warm reset initiated by a configuration request writing a one to the Fundamental Reset (FRST) bit in the Switch Control (SWCTL) register always results in the PES16T4G2 returning a Successful Completion to the requester before the warm reset process begins.

The PES16T4G2 provides a reset output signal for each downstream port implemented as a GPIO alternate function. When a Fundamental Reset occurs, all of the GPIO pins default to GPIO inputs. Therefore, the downstream port resets are tri-stated. A system designer should use a pull-down on these signals if they are used as reset outputs.

The operation of a Fundamental Reset with serial EEPROM initialization (i.e., SWMODE[2:0] = 0x1) is illustrated in Figure 2.1.

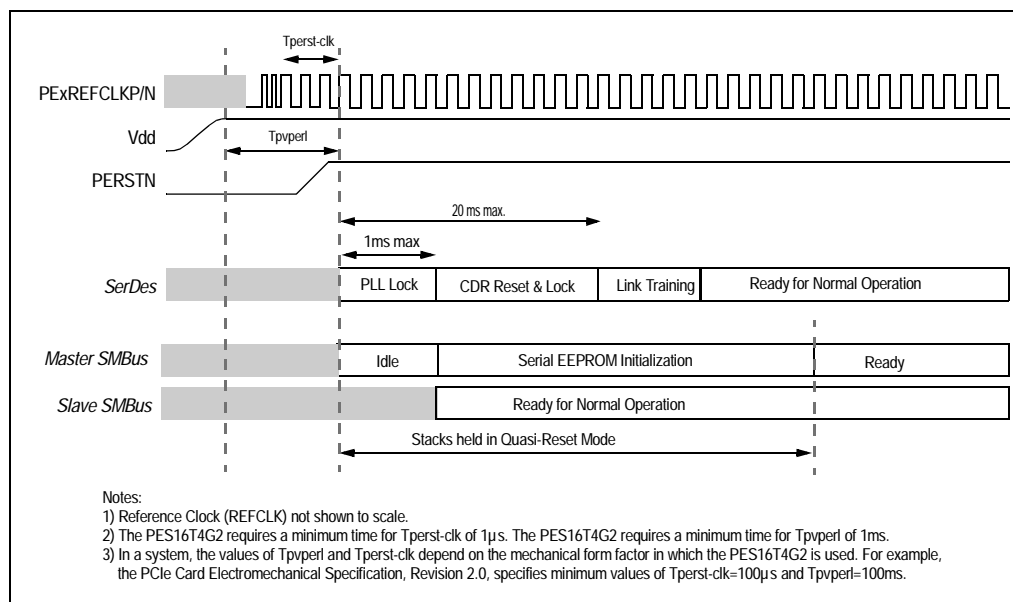

Figure 2.1 Fundamental Reset with Serial EEPROM Initialization

The operation of a Fundamental Reset using RSTHALT is illustrated in Figure 2.2.

Notes

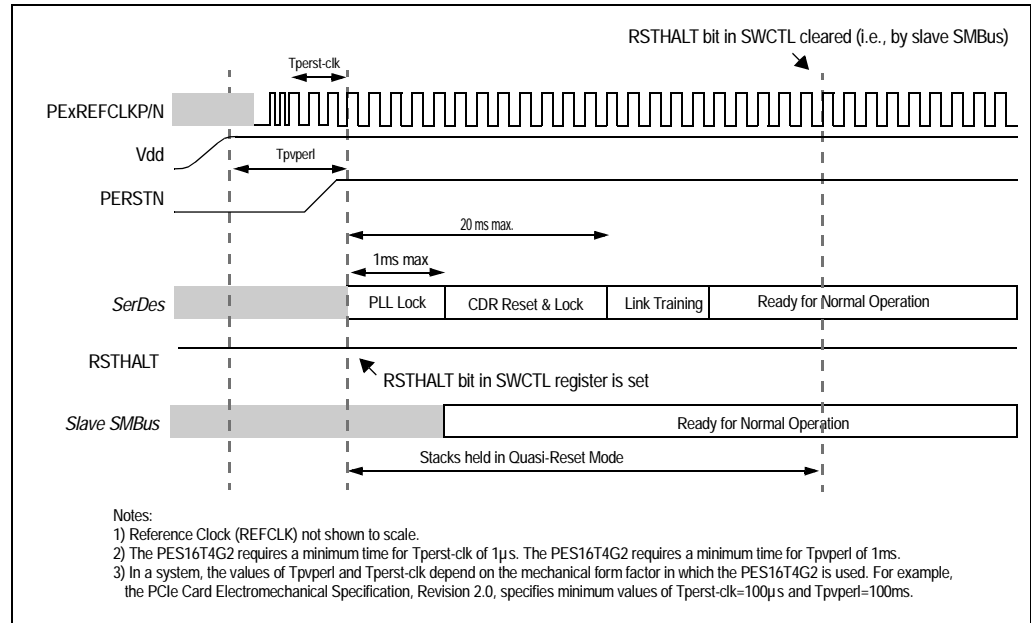

Figure 2.2 Fundamental Reset Using RSTHALT to Keep Device in Quasi-Reset State

Hot Reset

A hot reset may be initiated by any of the following conditions:

- Reception of TS1 ordered-sets on the upstream port indicating a hot reset.
- Data link layer of the upstream port transitions to the DL\_Down state.
- Writing a one to the Hot Reset (HRST) bit in the Switch Control (SWCTL) register.

The initiation of a hot reset due to the data link layer of the upstream port transitioning to the DL\_Down state may be disabled by setting the Disable Link Down Hot Reset (DLDHRS) bit in the Switch Control (SWCTL) register. Other hot reset conditions are unaffected by this bit.

When a hot reset occurs, the following sequence is executed.

1. Each downstream port whose link is up propagates the hot reset by transmitting TS1 ordered sets with the hot reset bit set.
2. All of the logic associated with the PES16T4G2 except the PLLs, SerDes, master SMBus interface, and slave SMBus interface is reset.
3. All register fields in all registers, except those denoted as "sticky" or Read and Write when Unlocked (i.e., RWL), are reset to their initial value. The value of fields denoted as "sticky" or RWL is preserved across a hot reset.
4. Link training begins. While link training is in progress, proceed to step 5.
5. The PCI Express stacks and associated logic are held in a quasi-reset state in which the following actions occur.
  - All links enter an active link training state within 20 ms of the clearing of the hot reset condition.
  - Within 100 ms of the clearing of the Hot Reset condition, all of the stacks are able to process configuration transactions and respond to these transactions with a configuration request retry status completion. All other transactions are ignored.
6. If the selected switch operating mode is one that requires initialization from the serial EEPROM and the Disable Hot Reset Serial EEPROM Initialization (DHRSTSEI) bit is not set in the Switch Control (SWCTL) register, then the contents of the serial EEPROM are read and the appropriate PES16T4G2 registers are updated.

## Notes

- If a one is written by the serial EEPROM to the Full Link Retrain (FLRET) bit in any Phy Link State 0 (PHYLSTATE0) register, then link retraining is initiated on the corresponding port using the current link parameters.
  - If an error is detected during loading of the serial EEPROM, then loading of the serial EEPROM is aborted and the RSTHALT bit is set in the SWCTL register. Error information is recorded in the SMBUSSTS register.
  - When serial EEPROM initialization completes or when an error is detected, the DONE bit in the SMBUSSTS register is set.
7. If the Reset Halt (RSTHALT) bit is set in the SWCTL register, all of the logic is held in a reset state except the master and slave SMBuses. The RSTHALT bit is only set if serial EEPROM initialization is enabled in step 6.
  8. Normal device operation begins.

The operation of the slave SMBus interface is unaffected by a hot reset. Using the slave SMBus to access a register that is reset by a hot reset causes zero to be returned on a read and written data to be ignored on writes.

A hot reset initiated by the writing of a one to the Hot Reset (HRST) bit in the Switch Control (SWCTL) register always results in the PES16T4G2 returning a completion to the requester before the hot reset process begins. Additionally, the upstream link is fully retrained (i.e., the upstream LTSSM transitions to the Detect state).

#### Upstream Secondary Bus Reset

An Upstream Secondary Bus Reset may be initiated by the following condition:

- A one is written to the Secondary Bus Reset (SRESET) bit in the upstream port's (i.e., port 0) Bridge Control Register (BCTL).

When an Upstream Secondary Bus Reset occurs, the following sequence is executed.

1. Each downstream port whose link is up propagates the reset by transmitting TS1 ordered sets with the hot reset bit set.
2. All registers fields in all registers associated with downstream ports, except those denoted as "sticky" or Read and Write when Unlocked (i.e, RWL), are reset to their initial value. The value of fields denoted as "sticky" or RWL is unaffected by an Upstream Secondary Bus Reset.
3. All TLPs received from downstream ports and queued in the PES16T4G2 are discarded.
4. Logic in the stack, application layer and switch core associated with the downstream ports are gracefully reset.
5. Wait for software to clear the Secondary Bus Reset (SRESET) bit in the upstream port's Bridge Control Register (BCTL).
6. Normal downstream port operation begins.

The operation of the upstream port is unaffected by a secondary bus reset. The link remains up and Type 0 configuration read and write transactions that target the upstream port complete normally.

During an Upstream Secondary Bus Reset, all TLPs destined to the secondary side of the upstream port's PCI-to-PCI bridge are treated in an undefined manner. The user should ensure no TLPs are sent to the secondary side of the upstream port's PCI-to-PCI bridge until the SRESET bit in the BCTL register is cleared.

The operation of the slave SMBus interface is unaffected by an Upstream Secondary Bus Reset. Using the slave SMBus to access a register that is reset by an Upstream Secondary Bus Reset causes the register's default value to be returned on a read and written data to be ignored on writes.

#### Downstream Secondary Bus Reset

A Downstream Secondary Bus Reset may be initiated by the following condition:

- A one is written to the Secondary Bus Reset (SRESET) bit in a downstream port's Bridge Control Register (BCTL).

## Notes

When a Downstream Secondary Bus Reset occurs, the following sequence is executed.

1. If the corresponding downstream port's link is up, TS1 ordered sets with the hot reset bit set are transmitted
2. All TLPs received from corresponding downstream port and queued in the PES16T4G2 are discarded.
3. Wait for software to clear the Secondary Bus Reset (SRESET) bit in the upstream port's Bridge Control Register (BCTL).
4. Normal downstream port operation begins.

The operation of the upstream port is unaffected by a Downstream Secondary Bus Reset.

The operation of other downstream ports is unaffected by a Downstream Secondary Bus Reset.

During a Downstream Secondary Bus Reset, Type 0 configuration read and write transactions that target the downstream port complete normally.

During a Downstream Secondary Bus Reset, all TLPs destined to the secondary side of the downstream port's PCI-to-PCI bridge are treated as unsupported requests.

The operation of the slave SMBus interface is unaffected by a Downstream Secondary Bus Reset.

## Downstream Port Reset Outputs

Individual downstream port reset outputs (P2RSTN, P4RSTN and P6RSTN) are provided as GPIO pin alternate functions.

Following a Fundamental Reset, all of the GPIO pins default to GPIO inputs. Therefore, the downstream port resets are tri-stated. A system designer should use a pull-down on these signals if they are used as reset outputs.

The PES16T4G2 ensures through hardware that the minimum P<sub>x</sub>RSTN assertion pulse width is no less than 200  $\mu$ s.

Downstream port reset outputs can be configured to operate in one of two modes. These modes are power enable controlled reset output and power good controlled reset output. The downstream port reset output mode is determined by the Reset Mode (RSTMODE) field in the Hot-Plug Configuration Control (HPCFGCTL) register.

### Power Enable Controlled Reset Output

In this mode a downstream port reset output state is controlled as a side effect of slot power being turned on or off. The operation of this mode is illustrated in Figure 2.3.

A downstream port's slot power is controlled by the Power Controller Control (PCC) bit in the PCI Express Slot Control (PCIESCTL) register

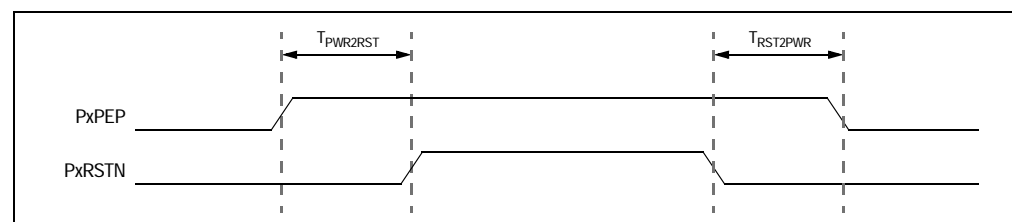

Figure 2.3 Power Enable Controlled Reset Output Mode Operation

While slot power is disabled, the corresponding downstream port reset output is asserted.

## Notes

When slot power is enabled by writing a zero to the PCC bit, the Port x Power Enable Output (PxPEP) is asserted and then power to the slot is enabled and the corresponding downstream port reset output is negated. The time between the assertion of the PxPEP signal and the negation of the PxRSTN signal is controlled by the value in the Slot Power to Reset Negation (PWR2RST) field in the HPCFGCTL register.

While slot power is enabled, the corresponding downstream port reset output is negated.

When slot power is disabled by writing a one to the PCC bit, the corresponding downstream port reset output is asserted and then slot power is disabled. The time between the assertion of the PxRSTN signal and the negation of the PxPEP signal is controlled by the value in the Reset Negation to Slot Power (RST2PWR) field in the HPCFGCTL register.

#### Power Good Controlled Reset Output

As in the Power Enable Controlled Reset mode, in this mode a downstream port reset output state is controlled as a side effect of slot power being turned on or off. However, the timing in this mode depends on the power good state of the slot's power supply. The operation of this mode is illustrated in Figure 2.4.

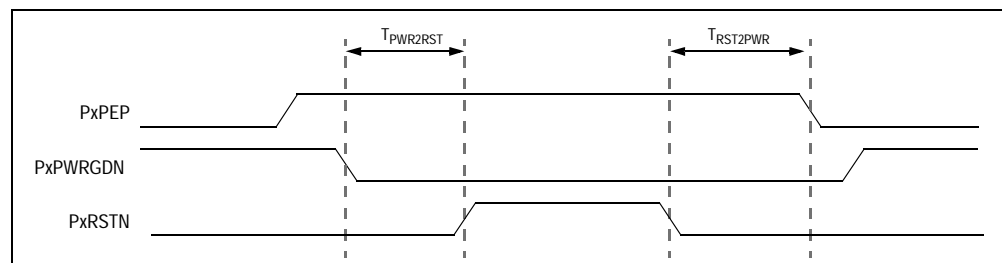

Figure 2.4 Power Good Controlled Reset Output Mode Operation

The operation of this mode is similar to that of the Power Enable Controlled Reset mode except that when power is enabled, the negation of the corresponding port reset output occurs as a result of and after assertion of the slot's Power Good (PxPWRGDN) signal is observed. The time between the assertion of the PxPWRGDN signal and the negation of the PxRSTN signal is controlled by the value in the Slot Power to Reset Negation (PWR2RST) field in the HPCFGCTL register.

When slot power is disabled by writing a one to the PCC bit, the corresponding downstream port reset output is asserted and then slot power is disabled. The time between the assertion of the PxRSTN signal and the negation of the PxPEP signal is controlled by the value in the Reset Negation to Slot Power (RST2PWR) field in the HPCFGCTL register.

If at any point while a downstream port is not being reset (i.e., PxRSTN is negated) a power fault is detected (i.e., PxPWRGDN is negated), then the corresponding port reset output is immediately asserted. Since the PxPWRGDN signal is an I/O expander input, it may not be possible to meet a profile's power level invalid to reset asserted timing specification (i.e., PxPWRGDN to PxRSTN). Systems that require a shorter time interval may implement this functionality external to the PES16T4G2.



# Link Operation

## Notes

### Introduction

Link operation in the PES16T4G2 adheres to the PCI Express 2.0 Base Specification, supporting speeds of 2.5 Gbps and 5.0 Gbps. The PES16T4G2 contains four ports. All ports operate with a maximum link width of x4. The SerDes lanes are statically assigned to a port.

### Polarity Inversion

Each port of the PES16T4G2 supports automatic polarity inversion as required by the PCIe specification. Polarity inversion is a function of the receiver and not the transmitter. The transmitter never inverts its data. During link training, the receiver examines symbols 6 through 15 of the TS1 and TS2 ordered sets for inversion of the PExRP[n] and PExRN[n] signals. If an inversion is detected, then logic for the receiving lane automatically inverts received data. Polarity inversion is a lane and not a link function. Therefore, it is possible for some lanes of link to be inverted and for others not to be inverted.

### Lane Reversal

The PCIe specification describes an optional lane reversal feature. The PES16T4G2 supports the automatic lane reversal feature outlined in the PCIe specification. The operation of lane reversal is dependent on the maximum link width selected by the MAXLNKWDTH field in the PCI Express Link Capabilities (PCIELCAP) register. Lane reversal mapping for the various non-trivial x4 port maximum link width configurations supported by the PES16T4G2 are illustrated in Figures 3.1 and 3.2.

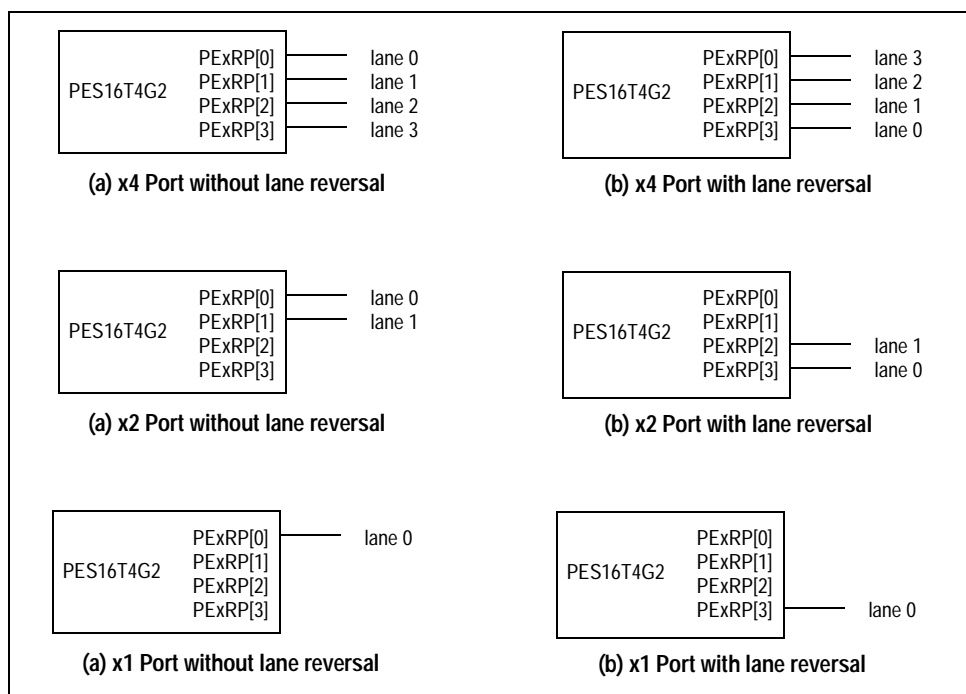

Figure 3.1 Port Lane Reversal for Maximum Link Width of x4 (MAXLNKWDTH=0x4)

## Notes

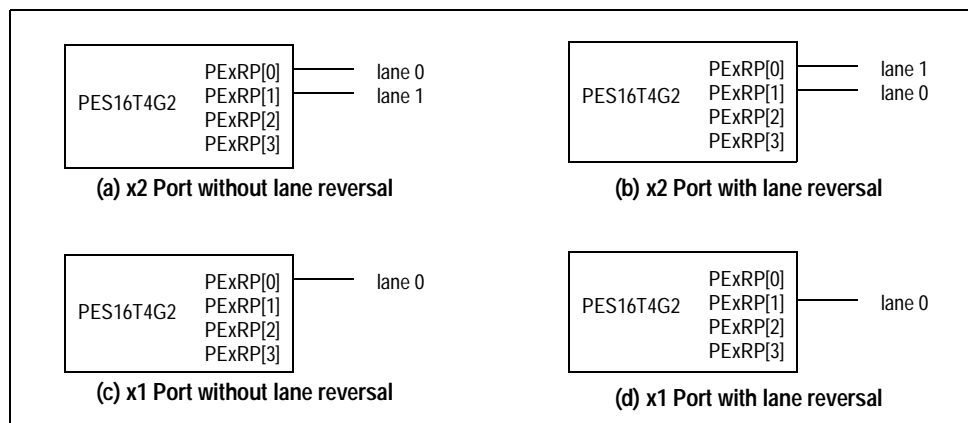

Figure 3.2 Port Lane Reversal for Maximum Link Width of x2 (MAXLNKWDTH=0x2)

## Link Width Negotiation

The PES16T4G2 supports the optional link variable width negotiation feature outlined in the PCIe 2.0 specification. The maximum port link width is discussed in section Port Configuration on page 1-10. The actual link width is determined dynamically during link training. Ports limited to a maximum link width of x4 are capable of negotiating to a x4, x2, or x1 link width.

The negotiated width of each link after a full link train<sup>1</sup> may be determined from the Negotiated Link Width (NLW) field in the corresponding port's PCIe Link Status (PCIELSTS) register. This field indicates the actual link width at the time the field is read.

The Maximum Link Width (MAXLNKWDTH) field in a port's PCI Express Link Capabilities (PCIELCAP) register contains the maximum link width of the port. This field is of RWL type and may be modified when the REGUNLOCK bit is set in the SWCTL register. Modification of this field allows the maximum link width of the port to be configured. The new link width takes effect the next time full link training occurs.

When a x4 port negotiates to a width less than x4, the unused SerDes lanes are put in a low power state. When a port is disabled, all SerDes lanes associated with that port are powered down.

## Dynamic Link Width Re-Configuration

### Background

The PCI Express 2.0 specification includes support for dynamic upconfiguration of link widths. This optional capability allows both components of a link to dynamically downconfigure & upconfigure links based on implementation specific criteria such as power savings, link bandwidth requirements, or link reliability problems.

As an example, a link that initially does a full link train to x4 may be dynamically downconfigured to x1 in order to save power when there is little traffic on the link. As traffic increases, the link may be dynamically upconfigured to its initial link width of x4. Also, the link width may be downconfigured if a particular lane is determined to be unreliable.

With dynamic link width re-configuration, the system designer can choose to connect components with enough lanes to handle worst case bandwidth requirements, yet not waste power when the link is not fully utilized. This capability offers an additional mechanism for link power reduction on top of the traditional ASPM link states (L0s, L1, etc.)

<sup>1</sup> A full link train is a link training in which the LTSSM transitions through the Detect state.



## Notes

Dynamic upconfiguration and downconfiguration is done on a per-link basis, and does not result in the link going into a DL\_Down state. A link can be downconfigured down to x1. A link can be upconfigured up to the negotiated link width set after a full link train. For example, a link that trained to a width of x2 after a full link train cannot be upconfigured to a width above x2.

When a link is downconfigured to a smaller width, inactive lanes are kept in Electrical Idle with their receiver terminations enabled. These lanes continue to be associated with the downconfigured port's LTSSM. In order for upconfiguration to occur successfully, both of the link components must support it. Furthermore, the PCIe specification recommends that a link component not initiate downconfiguration unless the link partner supports link upconfiguration, except for link reliability reasons.

The capability to upconfigure a link is transmitted among components using the in-band TS2 ordered set. When downconfiguration or upconfiguration of the link width occurs, one of the components on the link initiates the process, while the other component responds to the process. The PCIe specification indicates that both of these capabilities are optional.

Software may be notified of link width re-configuration via the link bandwidth notification mechanism described in the PCIe 2.0 specification. This mechanism is enabled by setting the Link Bandwidth Management Interrupt Enable (LBWINTEN) bit in the PCIELCTL register of switch downstream ports. Software can prevent a device from initiating link width re-configuration for reasons other than reliability by setting the Hardware Autonomous Width Disable (HAWD) bit in the port's Link Control Register (PCIELCTL). Note that the HAWD bit does not prevent a device from re-configuring the link width in response to link partner requests.

#### Dynamic Link Width Re-Configuration Support in the PES16T4G2

The PES16T4G2 supports dynamic link width upconfiguration and down-configuration in response to link partner requests. The PES16T4G2 ports do not autonomously initiate link width upconfiguration and downconfiguration of links. Therefore, the Hardware Autonomous Width Disable (HAWD) bit in the port's PCIELCTL register has no effect and is hardwired to 0x0. Additionally, the PES16T4G2 port's never set the 'Autonomous Change' bit in the training sets exchanged with the link partner during link training. Still, a link partner connected to a PES16T4G2 downstream port may autonomously change link width. When this occurs, the PES16T4G2 downstream port sets the Link Autonomous Bandwidth Status (LABWSTS) bit in the PCIELSTS register.

## Link Speed Negotiation

### Background

The PCIe 2.0 specification introduces support for 5.0 Gbps data rates per lane (a.k.a., Gen2), in addition to the 2.5 Gbps data rates (a.k.a, Gen1) mandated in previous versions of the specification. The PCIe spec indicates that Gen2 support is optional while Gen1 support is mandatory.

All lanes of a link must operate at the same data rate. During full link training (i.e., from the Detect state), links initially operate at 2.5 Gbps. Once the PHY Link Training State Machine (LTSSM) on both components of the link reach the L0 state, the link speed may be upgraded to 5.0 Gbps if this capability is advertised by both components. The process of upgrading the link speed does not result in a DL\_Down state.

A component advertises its supported speeds via the Data Rate Identifier bits in the TS1 and TS2 training sets transmitted to its link partner during link training. The PCIe spec permits a component to change its supported speeds dynamically. It is allowed for a component to advertise supported link speeds without necessarily changing the link speed, via the Recovery LTSSM state.

A component determines the supported speeds of its link partner by examining the Data Rate Identifier bits in the TS1/TS2 training sets received during link training, specifically in the Configuration.Complete and Recovery.RcvrCfg states. The latest advertisement received overrides any previously recorded value.

## Notes

It is the responsibility of the upstream component of the link (i.e., switch downstream ports) to keep the link at the target link speed or at the highest common speed supported by both components of the link, whichever is lower. Either link component may request a link speed change due to the following:

- Software commands via the Link Control registers (PCIELCTL and PCIELCTL2)
- Autonomous (i.e., implementation specific) mechanisms
- Link reliability reasons (i.e., speed downgrade).

A component must not initiate a link speed upgrade if it has never recorded support for the higher speed by its link partner since the last time the component exited the Detect state. Therefore, if a Gen2 capable component link-trains with a Gen1 only component, the Gen2 capable component will not request a link speed upgrade.

A component may initiate a link speed change if it has recorded support for the target speed by its link partner since exiting the Detect state. The link speed change operation via the Recovery state may succeed or fail, depending on the link partner's current support for the target speed as well as the link reliability at that speed. If it fails, the initiating component must wait 200ms before re-trying to upgrade the speed, or until the link partner advertises support for the higher speed.

The upstream component must initiate a link speed upgrade if it has recorded support for the higher speed by its link partner since exit from the Detect state, and software sets the Link Retrain bit in the PCIELCTL register with a target link speed which is not equal to the current link speed. Additionally, the upstream component (i.e., switch downstream port) is capable of notifying software of link speed changes via the Link Bandwidth Notification mechanism described in the PCIe 2.0 specification.

#### Link Speed Negotiation in the PES16T4G2

The PES16T4G2 ports support per lane data rates of 5.0 Gbps and 2.5 Gbps. The highest data rate of each link is determined dynamically, and depends on the following factors:

- Maximum link data rate supported by both components of the link
- The Target Link Speed set via the Link Control 2 Register (PCIELCTL2)
- The reliability of the link at 5.0 Gbps

By default, the Target Link Speed (TLS) of each port is set to 5.0 Gbps. Therefore, the PES16T4G2 ports advertise support for 2.5 Gbps and 5.0 Gbps during the link training process via training-sets. After a fundamental reset, each port link trains to the L0 state at 2.5 Gbps. If the Target Link Speed indicates 5.0 Gbps (default value), the PHY LTSSM automatically initiates link speed upgrade to 5.0 Gbps using the link speed change mechanism described in the PCIe 2.0 specification. This behavior applies to both upstream and downstream ports.

Note that in this case the Link Bandwidth Management Status (LBWSTS) bit in the PCIELSTS register of downstream port's is not set, since the initial link speed upgrade is not caused by a software directed link retrain or due to link reliability issues. The same behavior applies after full link retrain (i.e., when the LTSSM transitions through the 'Detect' state).

The current link speed of each port is reported via the Current Link Speed (CLS) field of the port's Link Status Register (PCIELSTS). Assuming the target link speed is set to 5.0 Gbps, the PES16T4G2 port initiates a link speed upgrade in the following cases:

- Link speed upgrade after initial link train to L0 at 2.5 Gbps, when the link partner advertised support for the higher speed.
- Link speed upgrade after full link retrain (i.e., via the Detect state) to L0 at 2.5 Gbps, when the link partner advertised support for the higher speed.
- Software sets the Link Retrain (LRET) bit in the PCIELCTL register, and the PES16T4G2 port has recorded support for the higher speed by its link partner since exit from the Detect state.

## Notes

When operating at 5.0 Gbps, the PES16T4G2 port initiates a link speed downgrade in the following cases:

- Link speed downgrade triggered when the PHY layer cannot achieve reliable operation at the higher speed. In this case, the PES16T4G2 port continues to support the higher speed in the training-sets it transmits during link training.
- Software sets the target link speed to 2.5 Gbps and sets the LRET bit in the PCIELCTL register. In this case, the PES16T4G2 port removes support for the higher speed in the training-sets it transmits during link training.

Additionally, the PES16T4G2 ports always respond to link partner requests to change speed. In this case, the speed change is only successful when both components in the link advertise support the target speed. When a link speed upgrade operation fails, the PHY LTSSM reverts back to the speed before the upgrade (i.e., 2.5 Gbps) and does not autonomously initiate a subsequent link speed upgrade. In this case, the PHY continues to support Gen1 and Gen2 data rates and therefore responds to link partner requests for link speed upgrade, or to link speed upgrades triggered by software setting the LRET bit in the PCIELCTL register.

A system designer may limit the maximum speed at which each port operates by changing the target link speed via software or EEPROM and forcing link retraining. For additional information, refer to section Software Management of Link Speed below.

### Software Management of Link Speed

Software can interact with the link control and status registers of each port to set the link speed, as well as receive notification of link speed changes. This gives software the capability to choose the desired link speed based on system specific criteria. For example, depending on the traffic load expected on a link, software can choose to downgrade link speed to 2.5 Gbps in order to reduce power on a low-traffic link, and later upgrade the link to 5.0 Gbps when the bandwidth is required. Software may also choose to change the link speed due to link reliability reasons (i.e., a link that has reliability problems at 5.0 Gbps may be downgraded to 2.5 Gbps).

As mentioned above, the Target Link Speed (TLS) field of the Link Control 2 Register (PCIELCTL2) sets the preferred link speed. By default, the Target Link Speed of each PES16T4G2 port is set to 5.0 Gbps.

In order to change link speed, software must write to the TLS field of the port's PCIELCTL2 register and subsequently force a link retrain by writing to the Link Retrain (LRET) bit of the Link Control (PCIELCTL) register. The port will only initiate the link speed change if it has recorded support for the higher speed by its link partner since exit from the Detect state. Else, the port will transition through the Recovery state without setting the 'Speed\_Change' bit in the transmitted training-sets.

Software is notified of link speed changes via the link bandwidth notification mechanism described in the PCIe 2.0 specification. This mechanism is enabled by setting the Link Bandwidth Management Interrupt Enable (LBWINTEN) bit in the PCIELCTL register of switch downstream ports. For downstream ports, when the link speed is changed due to the following reasons, the Link Bandwidth Management Status (LBWSTS) bit in the PCIELSTS register is set.

- Link speed downgrade initiated by a the PES16T4G2 port when the PHY layer cannot achieve reliable operation at the higher speed. Note that this does not include link speed downgrading due to failure to achieve symbol lock while upgrading link speed via the Recovery states.
- Link speed change initiated by the link partner that was not indicated as an autonomous change.

Also, the LBWSTS bit is set whenever software sets the LRET bit in the PCIELCTL register, even if the link speed is not changed. Note that the LBWSTS bit is not set during the initial link speed change (i.e., the speed change from Gen1 to Gen2 after fundamental reset or a full-link-retrain via the 'Detect' state). Additionally, for downstream ports, the Link Autonomous Bandwidth Status (LABWSTS) is set when the link partner initiates a link speed change that was indicated as an autonomous change.

## Notes

Software can verify the link speed by reading the Current Link Speed (CLS) field of the port's Link Status Register (PCIELSTS). Note that to force link speed to a value other than the default value, the TLS field could be configured through Serial EEPROM initialization and full link retraining forced. Finally, note that the Hardware Autonomous Speed Disable (HASD) bit has no effect on the PES16T4G2 ports and is hardwired to 0x0.

## Link Retraining

Per the PCIe 2.0 specification, link retraining can be done autonomously in response to link problems (i.e., repeated TLP replay attempts), or as a result of software setting the link retrain (LRET) bit in the PCI Express Link Control (PCIELCTL) register.

Writing a one to the Link Retrain (LRET) bit in a upstream port's PCI Express Link Control (PCIELCTL) register when the REGUNLOCK bit is set in the SWCTL register forces the upstream PCIe link to retrain. When this occurs the LTSSM transitions directly to the Recovery state.

Writing a one to the Link Retrain (LRET) bit in a downstream port's PCI Express Link Control (PCIELCTL) register regardless of the REGUNLOCK bit state in the SWCTL register forces the upstream PCIe link to retrain. When this occurs the LTSSM transitions directly to the Recovery state.

Writing a one to the Full Link Retrain (FLRET) bit in the Phy Link State 0 (PHYLSTATE0) register of any port forces that port's PCIe link to retrain. When this occurs the LTSSM transitions directly to the Detect state.

Link retraining does not result in the link going down, unless the LTSSM transitions through the Detect state in its retraining attempt. The speed of the link is not necessarily changed as a result of link retraining. A link that operates at 5.0 Gbps will continue to operate at that speed if the link retraining attempt is successful at that speed. Else, the link speed is changed to 2.5 Gbps.

When link retraining results in the speed of the link being downgraded from 5.0 Gbps to 2.5 Gbps, the Link Bandwidth Management Status (LBWSTS) bit is set in the PCI Express Link Status (PCIELSTS) register (for downstream ports only). Additionally, the PHY LTSSM remains at the downgraded speed until the link partner requests a link speed upgrade, software sets the LRET bit in the PCIELCTL register, or the link is fully retrained via the FLRET bit in the PHYLSTATE0 register.

When a link goes down, all TLPs received by that port and queued in the switch are discarded and all TLPs received by other ports and destined to the port whose link is down are treated as Unsupported Requests (UR). While a downstream link is down, it is possible to perform configuration read and write operations to the PCI-PCI bridge associated with that link. When a link comes up, flow control credits for the configured size of the IFB queues are advertised.

A link down condition on a downstream port's link may cause the Surprise Down Error Status (SDOENERR) bit to be set in the port's AER Uncorrectable Error Status (AERUES) register. The conditions under which surprise down is reported are described in Section 3.2.1 of the PCIe 2.0 Specification.

## Slot Power Limit Support

The Set\_Slot\_Power\_Limit message is used to convey a slot power limit value from a downstream switch port or root port to the upstream port of a connected device or switch.

### Upstream Port

When a Set\_Slot\_Power\_Limit message is received by the upstream switch port, then the fields in the message are written to the PCI Express Device Capabilities (PCIEDCAP) register of that port.

- Byte 0 bits 7:0 of the message payload are written to the Captured Slot Power Limit Scale (CSPLS) field.
- Byte 1 bits 1:0 of the message payload are written to the Captured Slot Power Limit Value (CSPLV) field.

## Notes

## Downstream Port

A Set\_Slot\_Power\_Limit message is sent by downstream switch ports when either of the following events occur:

- A configuration write is performed to the corresponding PCIESCAP register when the link associated with the downstream port is up.
- A link associated with the downstream port transitions from a non-operational state to an operational (i.e., data link up) state.

## Link States

The PES16T4G2 supports the following link states:

- L0
  - Fully operational link state
- L0s
  - Automatically entered low power state with shortest exit latency
- L1
  - Lower power state than L0s
  - May be automatically entered or directed by software by placing the device in the D3<sub>hot</sub> state
- L2/L3 Ready
  - The L2/L3 state is entered after the acknowledgement of a PM\_Turn\_Off Message.
  - There is no TLP or DLLP communications over a link in this state.
- L3
  - Link is completely unpowered and off
- Link Down
  - A transitional link down pseudo-state prior to L0. This pseudo-state is associated with the LTSSM Detect, Polling, Configuration, Disabled, Loopback and Hot-Reset states.

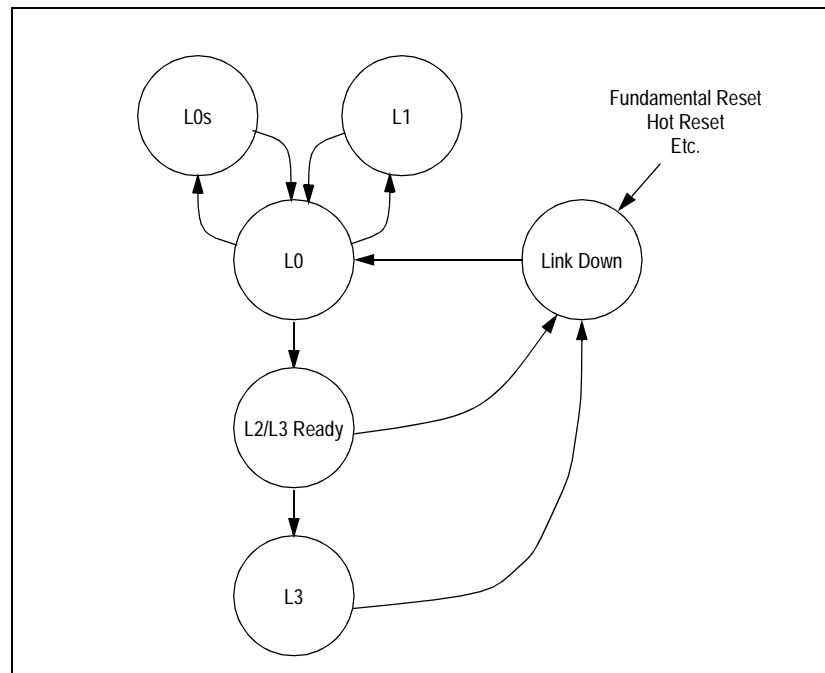

Figure 3.3 PES16T4G2 ASPM Link State Transitions

## Notes

## Active State Power Management

The operation of Active State Power Management (ASPM) is orthogonal to power management. Once enabled by the ASPM field in the PCI Express Link Control (PCIELCTL) register, ASPM link state transitions are initiated by hardware without software involvement. The PES16T4G2 ASPM supports the required L0s state as well as the optional L1 state.

The upstream switch port has the following L0s entry conditions.

- The receive lanes of all of the switch downstream ports which are not in a low power state (i.e., D3) and whose link is not down are in the L0s state.
- The switch has no TLPs to transmit on the upstream port or there are no available flow control credits to transmit a TLP.
- There are no DLLPs pending for transmission on the upstream port.

The downstream switch ports have the following L0s entry conditions.

- The receive lanes of the switch upstream port are in the L0s state.
- The switch has no TLPs to transmit on the downstream port or there are no available flow control credits to transmit a TLP.
- There are no DLLPs pending for transmission on the downstream port.

If the L1 Entry conditions are met and the link is in the L0 or L0s state, then the hardware will request a transition to the L1 state from its link partner. Note that L1 entry requests are only made by the PES16T4G2 upstream port. If the link partner acknowledges the transition, then the L1 state is entered. Otherwise the L0s state is entered.

- The upstream switch port will only request entry into the L1 state when all of the downstream ports which are not in a low power state (i.e., D3) and whose link is not down are in the L1 state.

## Link Status

Associated with each port is a Port Link Up (PxLINKUPN) status output and a Port Activity (PxACTIVEN) status output. These outputs are provided on I/O expander 4. See section I/O Expanders on page 5-6 for the operation of the I/O expander and the mapping of these status outputs to I/O expander pins.

The PxLINKUPN and PxACTIVEN status outputs may be used to provide a visual indication of system state and activity or for debug. The PxLINKUPN output is asserted when the PCIe data link layer is up (i.e., when the LTSSM is in the L0, L0s, L1 or recovery states). When the data link layer is down, this output is negated.

The PxACTIVEN output is asserted whenever any TLP, other than a vendor defined message, is transmitted or received on the corresponding port's link. Whenever a PxACTIVEN output is asserted, it remains asserted for at least 200 ms. Since an I/O expander output may change no more frequently than once every 40 ms, this translates into five I/O expander update periods.

## De-emphasis Negotiation

The PCI Express 2.0 specification requires that components support the following levels of de-emphasis, depending on the link data rate:

- 2.5 Gbps (Gen1): De-emphasis = -3.5dB
- 5.0 Gbps (Gen2): De-emphasis = -3.5dB or -6.0dB

When operating at 5.0 Gbps, the de-emphasis is selected by programming the Selectable De-emphasis (SDE) field in the PCI Link Control 2 Register (PCIELCTL2). The chosen de-emphasis for the link is the result of a negotiation between the components of the link. Both components must operate with the same de-emphasis across all lanes of the link.

## Notes

During normal operation (i.e., not polling/compliance), de-emphasis selection is done during the Recovery state. The downstream component of the link (i.e., switch upstream port or endpoint) advertises its desired de-emphasis by transmission of training sets. The upstream component of the link (i.e., switch downstream port or root-complex port) notes its link partner desired de-emphasis, and makes a decision about the de-emphasis to be used in the link.

The PES16T4G2's upstream port PHY advertises its desired de-emphasis based on the setting of the port's SDE field in the PCIELCTL2 register. The upstream PHY always accepts the link-partners decision on the de-emphasis to be used in the link. The PES16T4G2's downstream ports ignore the link partner's desired de-emphasis, and always choose the de-emphasis setting in the SDE field of the port's PCIELCTL2 register.

## Low-Swing Transmitter Voltage Mode

The PES16T4G2 ports support the optional low-swing transmit voltage mode defined in the PCIe 2.0 specification. In this mode, the transmitter's voltage level is set to approximately half the value of the full-swing (default) mode. This reduces power consumption in the SerDes. This mode is enabled by setting the Low-Swing Enable (LSE) bit in the port's SerDes Control (SERDESCTL) register.

When Low-Swing mode is enabled, the transmitter drive level is reduced and de-emphasis is automatically turned off. Therefore, the Selectable De-emphasis (SDE) and Compliance De-emphasis (CDE) fields in the PCIELCTL2 register have no effect. Additionally, the Current De-emphasis (CDE) field in the PCIELSTS2 register becomes invalid.

Notes





# General Purpose I/O

## Notes

## Introduction

The PES16T4G2 has 16 General Purpose I/O (GPIO) pins that may be individually configured as: general purpose inputs, general purpose outputs, or alternate functions. GPIO pins are controlled by the General Purpose I/O Function (GPIOFUNC), General Purpose I/O Configuration (GPIOCFG), and General Purpose I/O Data (GPIOD) registers in the upstream port's PCI configuration space. As shown in Table 4.1, some GPIO pins are shared with other on-chip functions. The GPIO Function (GPIOFUNC) register controls whether a GPIO bit operates as a general purpose I/O or as the specified alternate function.

GPIO Pin	Alternate Function Pin Name	Alternate Function Description	Alternate Function Pin Type
0	PE2RSTN	Reset output for downstream port 2	Output
1	PE4RSTN	Reset output for downstream port 4	Output
2	IOEXPINTN0	SMBus I/O expander interrupt 0	Input
4	IOEXPINTN2	SMBus I/O expander interrupt 2	Input
7	GPEN	General purpose event output	Output
11	PE6RSTN	Reset output for downstream port 6	Output

**Table 4.1 General Purpose I/O Pin Alternate Function**

After reset, all GPIO pins default to the GPIO input function. GPIO pins configured as GPIO inputs are sampled no more frequently than once every 128 ns and may be treated as asynchronous inputs. When a GPIO pin is configured to use the GPIO function, the unneeded alternate function associated with the pin is held in an inactive state by internal logic. Care should be exercised when configuring the GPIO pins as outputs since an incorrect configuration could cause damage to external components as well as the PES16T4G2.

## GPIO Configuration

Associated with each GPIO pin is a bit in the GPIOFUNC, GPIOCFG and GPIOD registers. Table 4.2 summarizes the configuration of GPIO pins.

GPIOFUNC	GPIOCFG	Pin Function
0	0	GPIO input
0	1	GPIO output
1	don't care	Alternate function

**Table 4.2 GPIO Pin Configuration**

## Notes

### GPIO Pin Configured as an Input

When configured as an input in the GPIOCFG register and as a GPIO function in the GPIOFUNC register, the GPIO pin is sampled and registered in the GPIOD register. The value of the input pin can be determined at any time by reading the GPIOD register. Note that the value in this register corresponds to the value of the pin irrespective of whether the pin is configured as a GPIO input, GPIO output, or alternate function.

### GPIO Pin Configured as an Output

When configured as an output in the GPIOCFG register and as a GPIO function in the GPIOFUNC register, the value in the corresponding bit position of the GPIOD register is driven on the pin. System designers should treat the GPIO outputs as asynchronous outputs. The actual value of the output pin can be determined by reading the GPIOD register.

### GPIO Pin Configured as an Alternate Function

When configured as an alternate function in the GPIOFUNC register, the pin behaves as described by the section associated with that function. The value of the alternate function pin can be determined at any time by reading the GPIOD register.



# SMBus Interfaces

## Notes

## Introduction

The PES16T4G2 contains two SMBus interfaces. The slave SMBus interface provides full access to all software visible registers in the PES16T4G2, allowing every register in the device to be read or written by an external SMBus master. The slave SMBus may also be used to preload the serial EEPROM used for initialization. The Master SMBus interface provides connection for an optional external serial EEPROM used for initialization and optional external I/O expanders. Six pins make up each of the two SMBus interfaces. These pins consist of an SMBus clock pin, an SMBus data pin, and 4 SMBus address pins. As shown in Figure 5.1, the master and slave SMBuses may be used in a unified or split configuration.

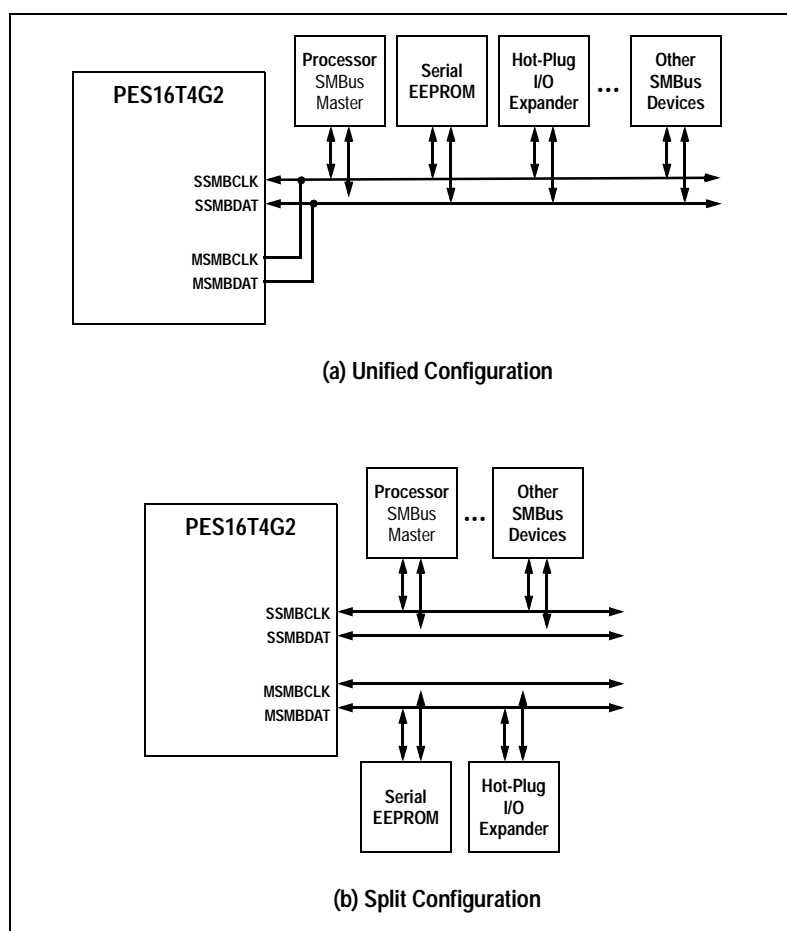

Figure 5.1 SMBus Interface Configuration Examples

In the unified configuration, shown in Figure 5.1(a), the master and slave SMBuses are tied together and the PES16T4G2 acts both as an SMBus master as well as an SMBus slave on this bus. This requires that the external SMBus master or processor that has access to the PES16T4G2 registers support SMBus arbitration. In some systems, this external SMBus master interface may be implemented using general purpose I/O pins on a processor or microcontroller, and thus may not support SMBus arbitration. To support these systems, the PES16T4G2 may be configured to operate in a split configuration as shown in Figure 5.1(b). In the split configuration, the master and slave SMBuses operate as two independent buses and thus multi-master arbitration is not required.

## Notes

## Master SMBus Interface

The master SMBus interface is used during a Fundamental Reset to load configuration values from an optional serial EEPROM. It is also used for optional I/O expanders used for hot-plug and other status signals.

## Initialization

Master SMBus initialization occurs during a Fundamental Reset (see section Fundamental Reset on page 2-3). During a Fundamental Reset initialization, the state of the Master SMBus Slow Mode (MSMBMODE) signal is examined. If this signal is asserted, then the Master SMBus Clock Prescaler (MSMBCP) field in the SMBus Control (SMBUSCTL) register is initialized to support 100 KHz SMBus operation. If the signal is negated, then the MSMBCP field is initialized for 400 KHz SMBus operation.

## Serial EEPROM

During a Fundamental or Hot Reset, an optional EEPROM may be used to initialize any software visible register in the device. Serial EEPROM initialization occurs if the Switch Mode (SWMODE[2:0]) field selects an operating mode that performs serial EEPROM initialization. The address used by the SMBus interface to access the serial EEPROM is specified by MSMBADDR[4:1] signals as shown in Table 5.1.

Address Bit	Address Bit Value
1	MSMBADDR[1]
2	MSMBADDR[2]
3	MSMBADDR[3]
4	MSMBADDR[4]
5	1
6	0
7	1

Table 5.1 Serial EEPROM SMBus Address

## Device Initialization from a Serial EEPROM

During initialization from the optional serial EEPROM, the master SMBus interface reads configuration blocks from the serial EEPROM and updates registers in the PES16T4G2. Any PES16T4G2 software visible register in any port may be initialized as stored in the serial EEPROM. Each software visible register in the PES16T4G2 has a CSR system address which is formed by adding the configuration space offset value of the register to the base address of the configuration space in which the register is located. Configuration blocks stored in the serial EEPROM use this CSR system address shifted right two bits (i.e., configuration blocks stored in the serial EEPROM use doubleword CSR system addresses and not byte CSR system addresses). Base addresses for configuration spaces in the PES16T4G2 are listed in Table 8.1, Base Addresses for Port Configuration Space Registers on page 8-1. Since configuration blocks are used to store only the value of those registers that are initialized, a serial EEPROM smaller than the total size of all of the configuration spaces may be used to initialize the device. Any EEPROM compatible with those listed in Table 5.2 may be used to store the PES16T4G2 initialization values. Some of these devices are larger than the total of the PCI configuration spaces in the PES16T4G2 that may be initialized and thus may not be fully utilized.

Notes

Serial EEPROM	Size
24C32	4 KB
24C64	8 KB
24C128	16 KB
24C256	32 KB
24C512	64 KB

Table 5.2 PES16T4G2 Compatible Serial EEPROMs

During serial EEPROM initialization, the master SMBus interface begins reading bytes starting at serial EEPROM address zero. These bytes are interpreted as configuration blocks and sequential reading of the serial EEPROM continues until the end of a configuration done block is reached or the serial EEPROM address rolls over from 0xFFFF to 0x0. All register initialization performed by the serial EEPROM is performed in double word quantities.

There are three configuration block types that may be stored in the serial EEPROM. The first type is a single double word initialization sequence. A double word initialization sequence occupies six bytes in the serial EEPROM and is used to initialize a single double word quantity in the PES16T4G2. A single double word initialization sequence consists of three fields and its format is shown in Figure 5.2. The CSR\_SYSADDR field contains the double word CSR system address of the double word to be initialized. The actual CSR system address, which is a byte address, equals this value with two lower zero bits appended. The next field is the TYPE field that indicates the type of the configuration block. For single double word initialization sequence, this value is always 0x0. The final DATA field contains the double word initialization value.

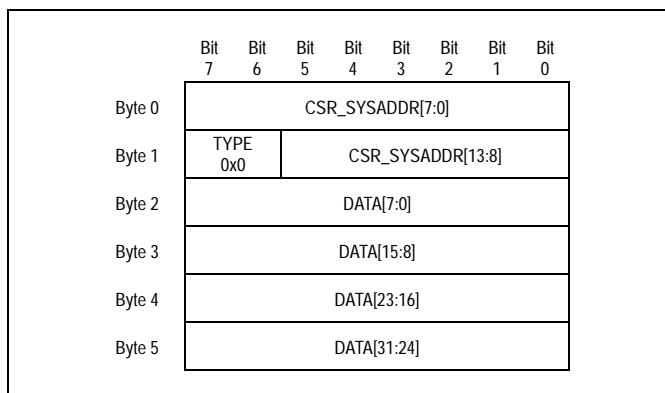

Figure 5.2 Single Double Word Initialization Sequence Format

The second type of configuration block is the sequential double word initialization sequence. It is similar to a single double word initialization sequence except that it contains a double word count that allows multiple sequential double words to be initialized in one configuration block.

A sequential double word initialization sequence consists of four required fields and one to 65535 double word initialization data fields. The format of a sequential double word initialization sequence is shown in Figure 5.3. The CSR\_SYSADDR field contains the starting double word CSR system address to be initialized. The next field is the TYPE field that indicates the type of the configuration block. For sequential double word initialization sequences, this value is always 0x1. The NUMDW field specifies the number of double words initialized by the configuration block. This is followed by the number of DATA fields specified in the NUMDW field.

Notes

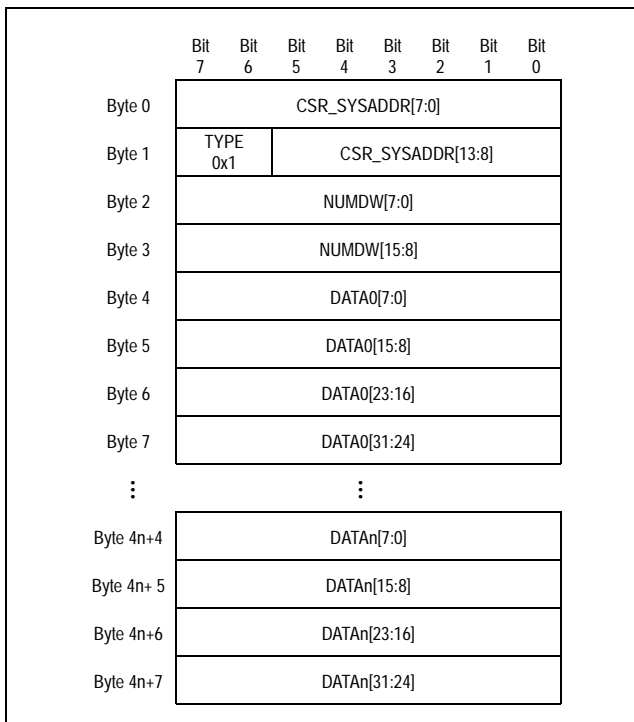

Figure 5.3 Sequential Double Word Initialization Sequence Format

The final type of configuration block is the configuration done sequence which is used to signify the end of a serial EEPROM initialization sequence. If during serial EEPROM initialization an attempt is made to initialize a register that is not defined in a configuration space (i.e., not defined in Chapter 8), then the Unmapped Register Initialization Attempt (URIA) bit is set in the SMBUSSTS register and the write is ignored. The configuration done sequence consists of two fields and its format is shown in Figure 5.3. The CHECKSUM field contains the checksum of all of the bytes in all of the fields read from the serial EEPROM from the first configuration block to the end of this done sequence. The second field is the TYPE field which is always 0x3 for configuration done sequences.

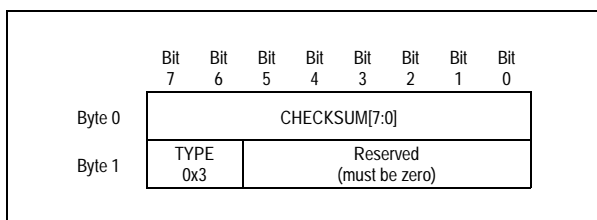

Figure 5.4 Configuration Done Sequence Format

The checksum in the configuration done sequence enables the integrity of the serial EEPROM initialization to be verified. Since uninitialized EEPROMs typically have a value of all ones, initialization from an uninitialized serial EEPROM will result in a checksum mismatch. The checksum is computed in the following manner. An 8-bit counter is initialized to zero and the 8-bit sum is computed over the configuration bytes stored in the serial EEPROM, including the entire contents of the configuration done sequence, with the checksum field initialized to zero.<sup>1</sup> The 1's complement of this sum is placed in the checksum field.

<sup>1</sup> This includes the byte containing the TYPE field.

## Notes

The checksum is verified in the following manner. An 8-bit counter is cleared and the 8-bit sum is computed over the bytes read from the serial EEPROM, including the entire contents of the configuration done sequence.<sup>1</sup> The correct result should always be 0xFF (i.e., all ones). Checksum checking may be disabled by setting the Ignore Checksum Errors (ICHECKSUM) bit in the SMBus Control (SMBUSCTL) register.

If an error is detected during loading of the serial EEPROM, then loading of the serial EEPROM is aborted and the RSTHALT bit is set in the SWCTL register. This allows debugging of the error condition via the slave SMBus interface but prevents normal system operation with a potentially incorrectly initialized device. Error information is recorded in the SMBUSSTS register. Once serial EEPROM initialization completes, or when an error is detected, the EEPROM Done (EEPROMDONE) bit is set in the SMBus Status (SMBUSSTS) register. A summary of possible errors during serial EEPROM initialization and specific action taken when detected is summarized in Table 5.3.

Error	Action Taken
Configuration Done Sequence checksum mismatch with that computed by the PES16T4G2	- Set RSTHALT bit in SWCTL register - ICSEERR bit is set in the SMBUSSTS register - Abort initialization, set DONE bit in the SMBUSSTS register
Serial EEPROM address roll-over from 0xFFFF to 0x0000	- Set RSTHALT bit in SWCTL register - ICSEERR bit is set in the SMBUSSTS register - Abort initialization, set DONE bit in the SMBUSSTS register
Invalid configuration block type (only invalid type is 0x2)	- Set RSTHALT bit in SWCTL register - ICSEERR bit is set in the SMBUSSTS register - Abort initialization, set DONE bit in the SMBUSSTS register
An unexpected NACK is observed during a master SMBus transaction	- Set RSTHALT bit in SWCTL register - NAERR bit is set in the SMBUSSTS register - Abort initialization, set DONE bit in the SMBUSSTS register
Master SMBus interface loses 16 consecutive arbitration attempts	- Set RSTHALT bit in SWCTL register - LAERR bit is set in the SMBUSSTS register - Abort initialization, set DONE bit in the SMBUSSTS register
A misplaced START or STOP condition is detected by the master SMBus interface	- Set RSTHALT bit in SWCTL register - OTHERERR bit is set in the SMBUSSTS register - Abort initialization, set DONE bit in the SMBUSSTS register

Table 5.3 Serial EEPROM Initialization Errors

### Programming the Serial EEPROM

The serial EEPROM may be programmed prior to board assembly or in-system via the slave SMBus interface or a PCIe root. Programming the serial EEPROM via the slave SMBus is described in [“Serial EEPROM Read or Write Operation” on page 5-14](#). A PCIe root may read and write the serial EEPROM by performing configuration read and write transactions to the Serial EEPROM Interface (EEPROMINTF) register.

To read a byte from the serial EEPROM, the root should configure the Address (ADDR) field in the EEPROMINTF register with the byte address of the serial EEPROM location to be read and the Operation (OP) field to “read.” The Busy (BUSY) bit should then be checked. If the EEPROM is not busy, then the read operation may be initiated by performing a write to the Data (DATA) field. When the serial EEPROM read operation completes, the Done (DONE) bit in the EEPROMINTF register is set and the busy bit is cleared. When this occurs, the DATA field contains the byte data of the value read from the serial EEPROM.

<sup>1</sup> This includes the checksum byte as well as the byte that contains the type and reserved field.

## Notes

To write a byte to the serial EEPROM, the root should configure the ADDR field with the byte address of the serial EEPROM location to be written and set the OP field to "write." If the serial EEPROM is not busy (i.e., the BUSY bit is cleared), the write operation may be initiated by writing the value to be written to the DATA field. When the write operation completes, the DONE bit is set and the busy bit is cleared. Initiating a serial EEPROM read or write operation when the BUSY bit is set produces undefined results.

SMBus errors may occur when accessing the serial EEPROM. If an error occurs, it is reported in the SMBus Status (SMBUSSTS) register. Software should check for errors before and after each serial EEPROM access.

## I/O Expanders

The PES16T4G2 utilizes external SMBus/I<sup>2</sup>C-bus I/O expanders connected to the master SMBus interface for hot-plug and port status signals. The PES16T4G2 is designed to work with Phillips PCA9555 compatible I/O expanders (i.e., PCA9555, PCA9535, and PCA9539). See the Phillips PCA9555 data sheet for details on the operation of this device.

An external SMBus I/O expander provides 16 bit I/O pins that may be configured as inputs or outputs.

The PES16T4G2 supports up to three external I/O expanders numbered 0, 2, and 4. Table 5.4 summarizes the allocation of functions to I/O expanders. I/O expanders zero and two are used to provide hot-plug I/O signals while I/O expander four is used to provide link status and activity LED control.

I/O expander signals associated with LED control (i.e., link status and activity) are active low (i.e., driven low when an LED should be turned on).

I/O expander signals associated with hot-plug signals are not inverted.

SMBus I/O Expander	Section	Function
0	Lower	Port 2 hot-plug
	Upper	Port 4 hot-plug
2	Lower	Port 6 hot-plug
	Upper	Power good inputs
4	Lower	Link status
	Upper	Link activity

Table 5.4 I/O Expander Function Allocation

During the PES16T4G2 initialization process, the SMBus/I<sup>2</sup>C-bus address allocated to each I/O expander used in that system configuration should be written to the corresponding IO Expander Address (IOE[0,2,4]ADDR) field. The IOE[0,2]ADDR fields are contained in the I/O Expander Address 0 (IOEXPADDR0) register while the IOE[4]ADDR fields are contained in the SMBus I/O Expander Address 1 (IOEXPADDR1) register.

Hot-plug outputs and I/O expanders may be initialized via serial EEPROM. Since the I/O expanders and serial EEPROM both utilize the master SMBus, no I/O expander transactions are initiated until serial EEPROM initialization completes.

- Since no I/O expander transactions are initiated until serial EEPROM initialization completes, it is not possible to toggle a hot-plug output through serial EEPROM initialization (i.e., it is not possible to cause a 0 -> 1 -> 0 transition or a 1 -> 0 -> 1 transition).

Whenever the value of an IOEXPADDR field is written, SMBus write transactions are issued to the corresponding I/O expander by the PES16T4G2 to configure the device. This configuration initializes the direction of each I/O expander signal and sets outputs to their default value.



## Notes

Outputs for ports that are disabled or are not implemented in that configuration or bond option, are set to their negated value (e.g., the power indicator is turned off, the link is down, there is no activity, etc.). The default value of I/O expander outputs is shown in Table 5.5. Note that this default value may be modified via serial EEPROM or SMBus configuration prior to SMBus initialization by changing the state of the PCI Express Slot Control Register (PCIESCTL) or Hot-Plug Configuration Control (HPCFGCTL).

SMBus I/O Expander Bit	Signal	Description	Default Value
(I/O-x.4)	P2AIN	Attention indicator output (off)	1
(I/O-x.5)	P2PIN	Power indicator output (on)	0
(I/O-x.6)	P2PEP	Power enable output (on)	1
(I/O-x.7)	P2ILOCKP	Electromechanical interlock (negated - off)	0

**Table 5.5 I/O Expander Default Output Signal Value**

The following I/O expander configuration sequence is issued by the PES16T4G2 to I/O expander zero (i.e., the one that contains hot-plug signals).

- Write the default value of the outputs bits on the lower eight I/O expander pins (i.e., I/O-0.0 through I/O-0.7) to I/O expander register 2.
- Write the default value of the outputs bits on the upper eight I/O expander pins (i.e., I/O-1.0 through I/O-1.7) to I/O expander register 3.
- Write value 0x0 to I/O expander register 4 (no inversion in IO-0)
- Write value 0x0 to I/O expander register 5 (no inversion in IO-1)
- Write the configuration value to select inputs/outputs in the lower eight I/O expander bits (i.e., I/O-0.0 through I/O-0.7) to I/O expander register 6.
- Write the configuration value to select inputs/outputs in the upper eight I/O expander bits (i.e., I/O-1.0 through I/O-1.7) to I/O expander register 7.
- Read value of I/O expander register 0 to obtain the current state of the lower eight I/O expander bits (i.e., I/O-0.0 through I/O-0.7)
- Read value of I/O expander register 1 to obtain the current state of the upper eight I/O expander bits (i.e., I/O-1.0 through I/O-1.7)

The following I/O expander configuration sequence is issued by the PES16T4G2 to I/O expander two (i.e., the one that contain hot-plug signals and power good inputs).

- Write the default value of the outputs bits on the lower eight I/O expander pins (i.e., I/O-0.0 through I/O-0.7) to I/O expander register 2.
- Write value 0x0 to I/O expander register 4 (no inversion in IO-0)
- Write value 0x0 to I/O expander register 5 (no inversion in IO-1)
- Write the configuration value to select inputs/outputs in the lower eight I/O expander bits (i.e., I/O-0.0 through I/O-0.7) to I/O expander register 6.
- Write the configuration value to select all inputs upper eight I/O expander bits (i.e., I/O-1.0 through I/O-1.7) to I/O expander register 7.
- Read value of I/O expander register 0 to obtain the current state of the lower eight I/O expander bits (i.e., I/O-0.0 through I/O-0.7)
- Read value of I/O expander register 1 to obtain the current state of the upper eight I/O expander bits (i.e., I/O-1.0 through I/O-1.7)

## Notes

The following I/O expander configuration sequence is issued by the PES16T4G2 to I/O expander four (i.e., the one that contains link up and link activity status).

- Write link up status for all ports to the lower eight I/O expander pins (i.e., I/O-0.0 through I/O-0.7) to I/O expander register 2.
- Write link activity status for all ports to the upper eight I/O expander pins (i.e., I/O-1.0 through I/O-1.7) to I/O expander register 3.
- Write value 0x0 to I/O expander register 4 (no inversion in IO-0)
- Write value 0x0 to I/O expander register 5 (no inversion in IO-1)
- Write the configuration value to select all outputs in the lower eight I/O expander bits (i.e., I/O-0.0 through I/O-0.7) to I/O expander register 6.
- Write the configuration value to select all outputs in the upper eight I/O expander bits (i.e., I/O-1.0 through I/O-1.7) to I/O expander register 7.

While the I/O expander is enabled, the PES16T4G2 maintains the I/O bus expander signals and the PES16T4G2 internal view of the hot-plug signals in a consistent state. This means that whenever that I/O bus expander state and the PES16T4G2 internal view of the signal state differs, an SMBus transaction is initiated by the PES16T4G2 to resolve the state conflict.

- An example of an event that may lead to a state conflict is a Hot Reset. When a Hot Reset occurs, one or more hot-plug register control fields may be re-initialized to its default value. When this occurs, the internal PES16T4G2 state of the hot-plug signals is in conflict with the state of I/O expander hot-plug output signals. In such a situation, the PES16T4G2 will initiate an SMBus transaction to modify the state of the I/O expander hot-plug outputs.

Each I/O expander has an open drain interrupt output that is asserted when a pin configured as an input changes state from the value previously read. Each interrupt output from an I/O expander should be connected to the corresponding PES16T4G2 I/O expander interrupt input. Since the PES16T4G2 I/O expander interrupt inputs are GPIO alternate functions, the corresponding GPIOs should be initialized during configuration to operate in alternate function mode. See Chapter 4, General Purpose I/O.

Whenever the PES16T4G2 needs to change the state of an I/O expander signal output, a master SMBus transaction is initiated to update the state of the I/O expander. This write operation causes the corresponding I/O expander to change the state of its output(s). The PES16T4G2 will not update the state of an I/O expander output more frequently than once every 40 milliseconds. This 40 millisecond time interval is referred to as the I/O expander update period.

Whenever an input to the I/O expander changes state from the value previously read, the interrupt output of the I/O expander is asserted. This causes the PES16T4G2 to issue a master SMBus transaction to read the updated state of the I/O expander inputs. Regardless of the state of the interrupt output of the I/O expander, the PES16T4G2 will not issue a master SMBus transaction to read the updated state of the I/O expander inputs more frequently than once every 40 milliseconds (i.e., the I/O expander update period). This delay in sampling may be used to eliminate external debounce circuitry.

The I/O expander interrupt request output is negated whenever the input values are read or when the input pin changes state back to the value previously read. The PES16T4G2 ensures that I/O expander transactions are initiated on the master SMBus in a fair manner. This guarantees that all I/O expanders have equal service latencies. Any errors detected during I/O expander SMBus read or write transactions is reflected in the status bits of the SMBus Status (SMBUSSTS) register.

The I/O Expander Interface (IOEXPINTF) register allows direct testing and debugging of the I/O expander functionality. The Select (SEL) field in the IOEXPINTF register selects the I/O expander number on which other fields in the register operate. The I/O Expander Data field in the IOEXPINTF register reflect the current state, as viewed by the PES16T4G2, of the I/O expander inputs and outputs selected by the SEL field.

Writing a one to the Reload I/O Expander Signals (RELOADIOEX) bit in the IOEXPINTF register causes the PES16T4G2 to generate SMBus write and read transactions to the I/O expander number selected in the SEL field. This results in the value of the IOEDATA field being updated to reflect the current state of the corresponding I/O expander signals. This feature may be used to aid in debugging I/O expander operation.

## Notes

For example, a user who neglects to configure a GPIO as an alternate function may use this feature to determine that master SMBus transactions to the I/O expander function properly and that the issue is with the interrupt logic.

The IO Expander Test Mode (IOEXTM) bit in the IOEXPTINF register allows an I/O expander test mode to be entered. When this bit is set, Whitney core logic outputs are ignored and the values written to the I/O expander for output bits are the values in the IOEDATA field. In this mode, the PES16T4G2 issues a transaction to update the state of the I/O expander whenever a bit corresponding to an I/O expander output changes state due to a write to the IOEDATA field. Bits in the IOEDATA field that correspond to outputs are dependent on the I/O expander number selected in the SEL field in the IOEXPINTF register. The outputs for each I/O expander number are shown in Tables 5.6 through 5.8.

System design recommendations include:

- I/O expander addresses and default output values may be configured during serial EEPROM initialization. If I/O expander addresses are configured via the serial EEPROM, then the PES16T4G2 will initialize the I/O expanders when normal device operation begins following the completion of the Fundamental Reset sequence.
- If the I/O expanders are initialized via serial EEPROM, then the data value for output signals during the SMBus initialization sequence will correspond to those at the time the SMBus transactions are initiated. It is not possible to toggle SMBus I/O expander outputs by modifying data values during serial EEPROM initialization.
- During a Fundamental Reset and before the I/O expander outputs are initialized, all I/O expander output signals default to inputs. Therefore, pull-up or pull-down resistors should be placed on outputs to ensure that they are held in the desired state during this period.
- All hot-plug data value modifications that correspond to hot-plug outputs result in SMBus transactions. This includes modifications due to Upstream Secondary Bus Resets and hot-resets.
- I/O expander outputs are not modified when the device transitions from normal operation to a Fundamental Reset. In systems where I/O expander output values must be reset during a Fundamental Reset, a PCA9539 I/O expander should be used.

**I/O Expander 0**

SMBus I/O Expander Bit	Type	Signal	Description
0 (I/O-0.0) <sup>1</sup>	I	P2APN	Port 2 attention push button input
1 (I/O-0.1)	I	P2PDN	Port 2 presence detect input
2 (I/O-0.2)	I	P2PFN	Port 2 power fault input
3 (I/O-0.3)	I	P2MRLN	Port 2 manually-operated retention latch (MRL) input
4 (I/O-0.4)	O	P2AIN	Port 2 attention indicator output
5 (I/O-0.5)	O	P2PIN	Port 2 power indicator output
6 (I/O-0.6)	O	P2PEP	Port 2 power enable output
7 (I/O-0.7)	O	P2ILOCKP	Port 2 electromechanical interlock
8 (I/O-1.0)	I	P4APN	Port 4 attention push button input
9 (I/O-1.1)	I	P4PDN	Port 4 presence detect input
10 (I/O-1.2)	I	P4PFN	Port 4 power fault input
11 (I/O-1.3)	I	P4MRLN	Port 4 manually-operated retention latch (MRL) input
12 (I/O-1.4)	O	P4AIN	Port 4 attention indicator output

Table 5.6 I/O Expander 0 Signals (Part 1 of 2)

## Notes

SMBus I/O Expander Bit	Type	Signal	Description
13 (I/O-1.5)	0	P4PIN	Port 4 power indicator output
14 (I/O-1.6)	0	P4PEP	Port 4 power enable output
15 (I/O-1.7)	0	P4ILOCKP	Port 4 electromechanical interlock

Table 5.6 I/O Expander 0 Signals (Part 2 of 2)

<sup>1</sup>: I/O-x.y corresponds to the notation used for PCA9555 port x I/O pin y.

**I/O Expander 2**

SMBus I/O Expander Bit	Type	Signal	Description
0 (I/O-0.0) <sup>1</sup>	I	P6APN	Port 6 attention push button input
1 (I/O-0.1)	I	P6PDN	Port 6 presence detect input
2 (I/O-0.2)	I	P6PFN	Port 6 power fault input
3 (I/O-0.3)	I	P6MRLN	Port 6 manually-operated retention latch (MRL) input
4 (I/O-0.4)	0	P6AIN	Port 6 attention indicator output
5 (I/O-0.5)	0	P6PIN	Port 6 power indicator output
6 (I/O-0.6)	0	P6PEP	Port 6 power enable output
7 (I/O-0.7)	0	P6ILOCKP	Port 6 electromechanical interlock
8 (I/O-1.0)	I	-	Unused
9 (I/O-1.1)	I	-	Unused
10 (I/O-1.2)	I	P2PWRGDN	Port 2 power good input
11 (I/O-1.3)	I	-	Unused
12 (I/O-1.4)	I	P4PWRGDN	Port 4 power good input
13 (I/O-1.5)	I	-	Unused
14 (I/O-1.6)	I	P6PWRGDN	Port 6 power good input
15 (I/O-1.7)	I	-	Unused

Table 5.7 I/O Expander 2 Signals

<sup>1</sup>: I/O-x.y corresponds to the notation used for PCA9555 port x I/O pin y.

**I/O Expander 4**

SMBus I/O Expander Bit	Type	Signal	Description
0 (I/O-0.0) <sup>1</sup>	0	P0LINKUPN	Port 0 link up status output
1 (I/O-0.1)	0	-	Unused
2 (I/O-0.2)	0	P2LINKUPN	Port 2 link up status output

Table 5.8 I/O Expander 4 Signals

Notes

SMBus I/O Expander Bit	Type	Signal	Description
3 (I/O-0.3)	0	-	Unused
4 (I/O-0.4)	0	P4LINKUPN	Port 4 link up status output
5 (I/O-0.5)	0	-	Unused
6 (I/O-0.6)	0	P6LINKUPN	Port 6 link up status output
7 (I/O-0.7)	0	-	Unused
8 (I/O-1.0)	0	P0ACTIVEN	Port 0 activity output
9 (I/O-1.1)	0	-	Unused
10 (I/O-1.2)	0	P2ACTIVEN	Port 2 activity output
11 (I/O-1.3)	0	-	Unused
12 (I/O-1.4)	0	P4ACTIVEN	Port 4 activity output
13 (I/O-1.5)	0	-	Unused
14 (I/O-1.6)	0	P6ACTIVEN	Port 6 activity output
15 (I/O-1.7)	0	-	Unused

**Table 5.8 I/O Expander 4 Signals**

<sup>1</sup> I/O-x.y corresponds to the notation used for PCA9555 port x I/O pin y.

### Slave SMBus Interface

The slave SMBus interface provides the PES16T4G2 with a configuration, management and debug interface. Using the slave SMBus interface, an external master can read or write any software visible register in the device.

#### Initialization

Slave SMBus initialization occurs during a Fundamental Reset (see section Fundamental Reset on page 2-3). During the Fundamental Reset initialization sequence, the slave SMBus address is initialized. The address is specified by the SSMBADDR[5,3:1] signals as shown in Table 5.9.

Address Bit	Address Bit Value
1	SSMBADDR[1]
2	SSMBADDR[2]
3	SSMBADDR[3]
4	0
5	SSMBADDR[5]
6	1
7	1

**Table 5.9 Slave SMBus Address When a Static Address is Selected.**

## Notes

## SMBus Transactions

The slave SMBus interface responds to the following SMBus transactions initiated by an SMBus master. See the SMBus 2.0 specification for a detailed description of these transactions.

- Byte and Word Write/Read
- Block Write/Read

Initiation of any SMBus transaction other than those listed above to the slave SMBus interface produces undefined results. Associated with each of the above transactions is a command code. The command code format for operations supported by the slave SMBus interface is shown in Figure 5.5 and described in Table 5.10.

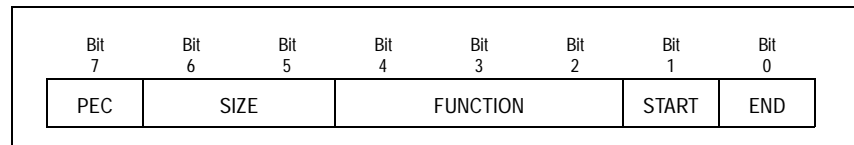

Figure 5.5 Slave SMBus Command Code Format

Bit Field	Name	Description
0	END	End of transaction indicator. Setting both START and END signifies a single transaction sequence 0 - Current transaction is not the last read or write sequence. 1 - Current transaction is the last read or write sequence.
1	START	Start of transaction indicator. Setting both START and END signifies a single transaction sequence 0 - Current transaction is not the first of a read or write sequence. 1 - Current transaction is the first of a read or write sequence.
4:2	FUNCTION	This field encodes the type of SMBus operation. 0 - CSR register read or write operation 1 - Serial EEPROM read or write operation 2 through 7 - Reserved
6:5	SIZE	This field encodes the data size of the SMBus transaction. 0 - Byte 1 - Word 2 - Block 3 - Reserved
7	PEC	This bit controls whether packet error checking is enabled for the current SMBus transaction. 0 - Packet error checking disabled for the current SMBus transaction. 1 - Packet error checking enabled for the current SMBus transaction.

Table 5.10 Slave SMBus Command Code Fields

The FUNCTION field in the command code indicates if the SMBus operation is a CSR register read/write or a serial EEPROM read/write operation. Since the format of these transactions is different, they will be described individually in the following sections. If a command is issued while one is already in progress or if the slave is unable to supply data associated with a command, then the command is NACKed. This indicates to the master that the transaction should be retried.

Notes

**CSR Register Read or Write Operation**

Table 5.11 indicates the sequence of data as it is presented on the slave SMBus following the byte address of the Slave SMBus interface.

Byte Position	Field Name	Description
0	CCODE	<b>Command Code.</b> Slave Command Code field described in Table 5.10.
1	BYTCNT	<b>Byte Count.</b> The byte count field is only transmitted for block type SMBus transactions. SMBus word and byte accesses do not contain this field. The byte count field indicates the number of bytes following the byte count field when performing a write or setting up for a read. The byte count field is also used when returning data to indicate the number of following bytes (including status). <i>Note that the byte count field does not include the PEC byte if PEC is enabled.</i>
2	CMD	<b>Command.</b> This field encodes fields related to the CSR register read or write operation.
3	ADDRL	<b>Address Low.</b> Lower 8-bits of the doubleword CSR system address of register to access.
4	ADDRU	<b>Address Upper.</b> Upper 6-bits of the doubleword CSR system address of register to access. Bits 6 and 7 in the byte must be zero and are ignored by the hardware.
5	DATALL	<b>Data Lower.</b> Bits [7:0] of data doubleword.
6	DATALM	<b>Data Lower Middle.</b> Bits [15:8] of data doubleword.
7	DATAUM	<b>Data Upper Middle.</b> Bits [23:16] of data doubleword.
8	DATAUU	<b>Data Upper.</b> Bits [31:24] of data doubleword.

**Table 5.11 CSR Register Read or Write Operation Byte Sequence**

Table 5.11 indicates the sequence of data as it is presented on the slave SMBus following the byte address of the Slave SMBus interface. Dword addresses and not byte addresses must be used to access all visible software registers. ADDR\_L and ADDR\_U represent the lower 8-bit of the doubleword system address and upper 6-bit doubleword system address, respectively. For example, use ADDR\_U = x00 and ADDR\_L = 0x00 to access system address 0x00000 (port 0's Vendor/Device ID register). Use ADDR\_U = x00 and ADDR\_L = 0x01 to access system address 0x00004 (port 0's Command/Status register).

The format of the CMD field is shown in Figure 5.6 and described in Table 5.12.

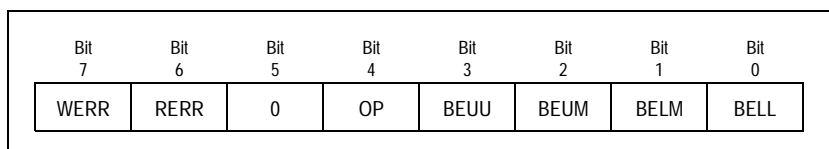

**Figure 5.6 CSR Register Read or Write CMD Field Format**

## Notes

Bit Field	Name	Type	Description
0	BELL	Read/Write	<b>Byte Enable Lower.</b> When set, the byte enable for bits [7:0] of the data word is enabled.
1	BELM	Read/Write	<b>Byte Enable Lower Middle.</b> When set, the byte enable for bits [15:8] of the data word is enabled.
2	BEUM	Read/Write	<b>Byte Enable Upper Middle.</b> When set, the byte enable for bits [23:16] of the data word is enabled.
3	BEUU	Read/Write	<b>Byte Enable Upper.</b> When set, the byte enable for bits [31:24] of the data word is enabled.
4	OP	Read/Write	CSR Operation. This field encodes the CSR operation to be performed. 0 - CSR write 1 - CSR read
5	0	0	Reserved. Must be zero
6	RERR	Read-Only and Clear	Read Error. This bit is set if the last CSR read SMBus transaction was not claimed by a device. Success indicates that the transaction was claimed and not that the operation completed without error.
7	WERR	Read-Only and Clear	Write Error. This bit is set if the last CSR write SMBus transaction was not claimed by a device. Success indicates that the transaction was claimed and not that the operation completed without error.

Table 5.12 CSR Register Read or Write CMD Field Description

**Serial EEPROM Read or Write Operation**

Table 5.12 indicates the sequence of data as it is presented on the slave SMBus following the byte address of the Slave SMBus interface.

Byte Position	Field Name	Description
0	CCODE	<b>Command Code.</b> Slave Command Code field described in Table 5.10.
1	BYCNT	<b>Byte Count.</b> The byte count field is only transmitted for block type SMBus transactions. SMBus word and byte accesses to not contain this field. The byte count field indicates the number of bytes following the byte count field when performing a write or setting up for a read. The byte count field is also used when returning data to indicate the number of following bytes (including status).
2	CMD	<b>Command.</b> This field contains information related to the serial EEPROM transaction
3	EEADDR	<b>Serial EEPROM Address.</b> This field specifies the address of the Serial EEPROM on the Master SMBus when the USA bit is set in the CMD field. Bit zero must be zero and thus the 7-bit address must be left justified.

Table 5.13 Serial EEPROM Read or Write Operation Byte Sequence



Notes

Byte Position	Field Name	Description
4	ADDRL	<b>Address Low.</b> Lower 8-bits of the Serial EEPROM byte to access.
5	ADDRU	<b>Address Upper.</b> Upper 8-bits of the Serial EEPROM byte to access.
6	DATA	<b>Data.</b> Serial EEPROM value read or to be written.

Table 5.13 Serial EEPROM Read or Write Operation Byte Sequence

The format of the CMD field is shown in Figure 5.7 and described in Table 5.14.

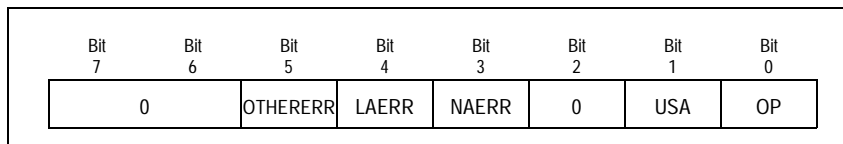

Figure 5.7 Serial EEPROM Read or Write CMD Field Format

Bit Field	Name	Type <sup>1</sup>	Description
0	OP	RW	Serial EEPROM Operation. This field encodes the serial EEPROM operation to be performed. 0 - Serial EEPROM write 1 - Serial EEPROM read
1	USA	RW	<b>Use Specified Address.</b> When this bit is set the serial EEPROM SMBus address specified in the EEADDR is used instead of that specified in the ADDR field in the EEPROMINTF register.  When this bit is set the serial EEPROM SMBus address specified in the EEADDR is used instead of that specified in the MSMBADDR field in the SMBUSSTS register.
2	Reserved		
3	NAERR	RC	No Acknowledge Error. This bit is set if an unexpected NACK is observed during a master SMBus transaction when accessing the serial EEPROM. This bit has the same function as the NAERR bit in the SMBUSSTS register.  The setting of this bit may indicate the following: that the addressed device does not exist on the SMBus (i.e., addressing error), data is unavailable or the device is busy, an invalid command was detected by the slave, invalid data was detected by the slave.
4	LAERR	RC	Lost Arbitration Error. This bit is set if the master SMBus interface loses 16 consecutive arbitration attempts when accessing the serial EEPROM. This bit has the same function as the LAERR bit in the SMBUSSTS register.
5	OTHERERR	RC	Other Error. This bit is set if a misplaced START or STOP condition is detected by the master SMBus interface when accessing the serial EEPROM. This bit has the same function as the OTHERERR bit in the SMBUSSTS register.
7:6	Reserved	0	Reserved. Must be zero.

Table 5.14 Serial EEPROM Read or Write CMD Field Description

Notes

<sup>1</sup> See Table 2 in the About This Manual chapter for a definition of these abbreviations.

**Sample Slave SMBus Operation**

This section illustrates sample Slave SMBus operations. Shaded items are driven by the PES16T4G2's slave SMBus interface and non-shaded items are driven by an SMBus host.

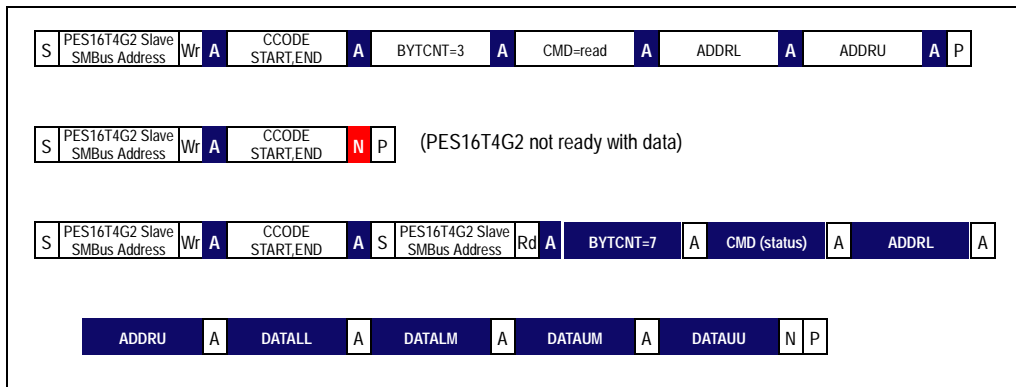

Figure 5.8 CSR Register Read Using SMBus Block Write/Read Transactions with PEC Disabled

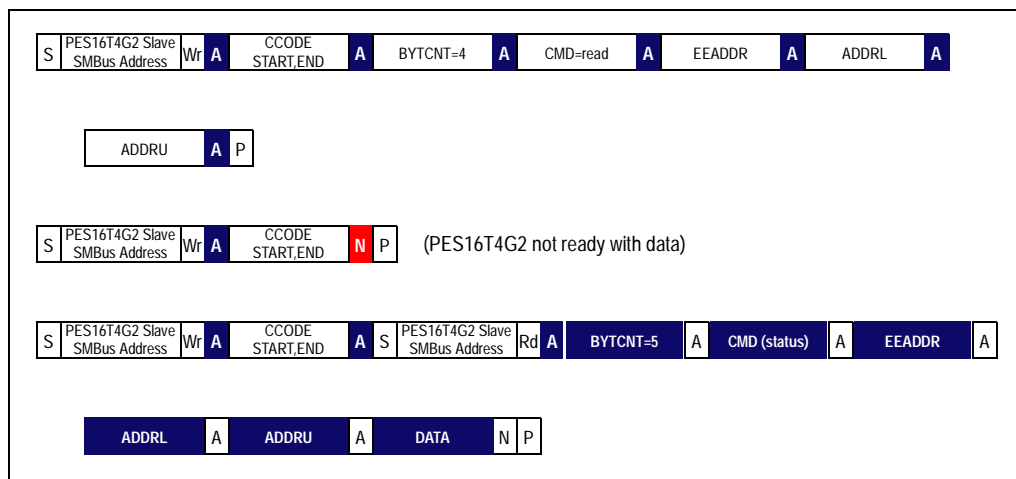

Figure 5.9 Serial EEPROM Read Using SMBus Block Write/Read Transactions with PEC Disabled

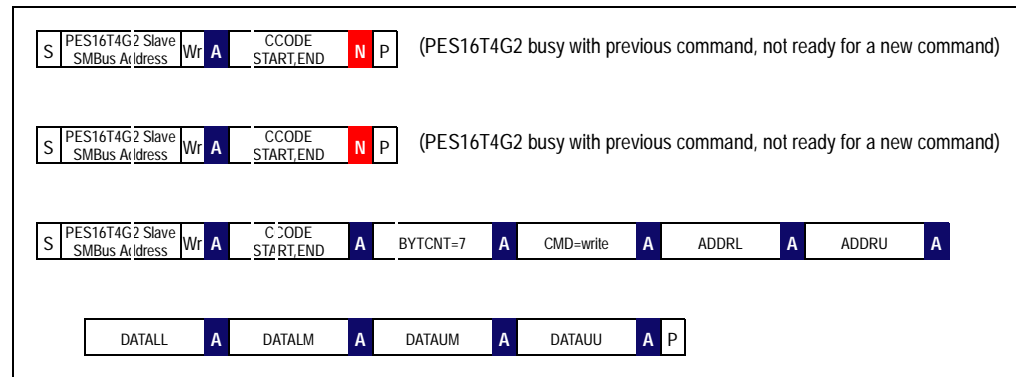

Figure 5.10 CSR Register Write Using SMBus Block Write Transactions with PEC Disabled

Notes

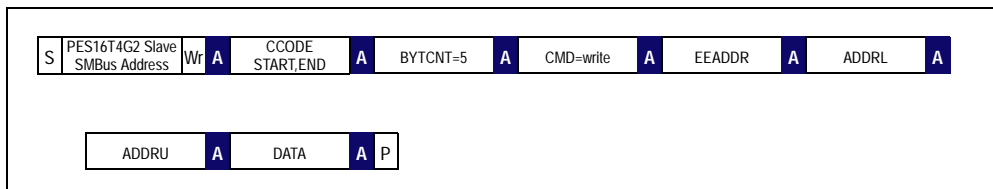

Figure 5.11 Serial EEPROM Write Using SMBus Block Write Transactions with PEC Disabled

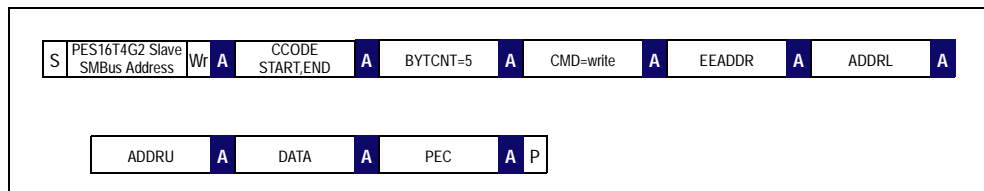

Figure 5.12 Serial EEPROM Write Using SMBus Block Write Transactions with PEC Enabled

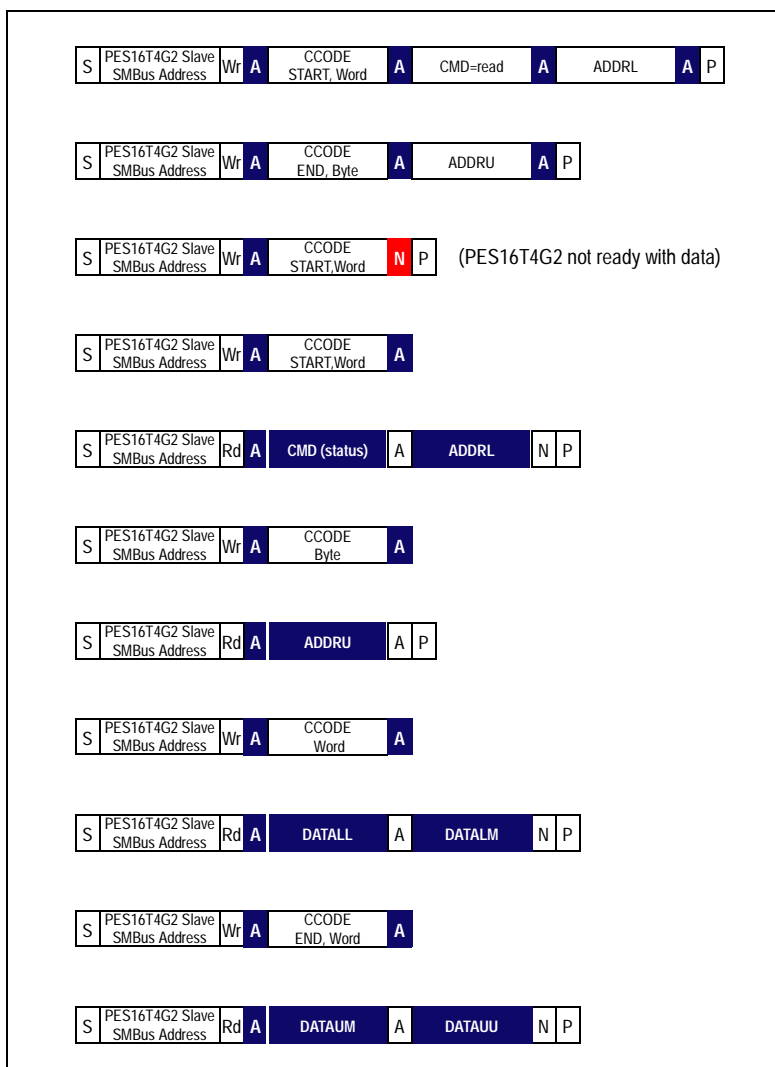

Figure 5.13 CSR Register Read Using SMBus Read and Write Transactions with PEC Disabled

Notes



# Power Management

## Notes

### Introduction

Located in configuration space of each PCI-PCI bridge in the PES16T4G2 is a power management capability structure. The power management capability structure associated with a PCI-PCI bridge of a downstream port only affects that port. Entering the D3<sub>Hot</sub> state allows the link associated with the bridge to enter the L1 state.

- The link associated with a port in the D3<sub>Hot</sub> state will attempt to transition into L1 link state irrespective of the link or power management state of any other switch port.

The power management capability structure associated with the upstream port (i.e., Port 0) affects the entire device. When the upstream port enters a low power state and the PME\_TO\_Ack messages are received, then the entire device is placed into a low power state. The PES16T4G2 supports the following device power management states: D0 Uninitialized, D0 Active, D3<sub>Hot</sub>, and D3<sub>Cold</sub>.

A power management state transition diagram for the states supported by the PES16T4G2 is provided in Figure 6.1 and described in Table 6.1. Transitioning a port's power management state from D3<sub>hot</sub> to D0<sub>uninitialized</sub> does not result in any logic being reset or re-initialization of register values. Thus, the default value of the No Soft Reset (NOSOFTTRST) bit in the PCI Power Management Control and Status (PMCSR) register corresponds to the functional context being maintained in the D3<sub>hot</sub> state.

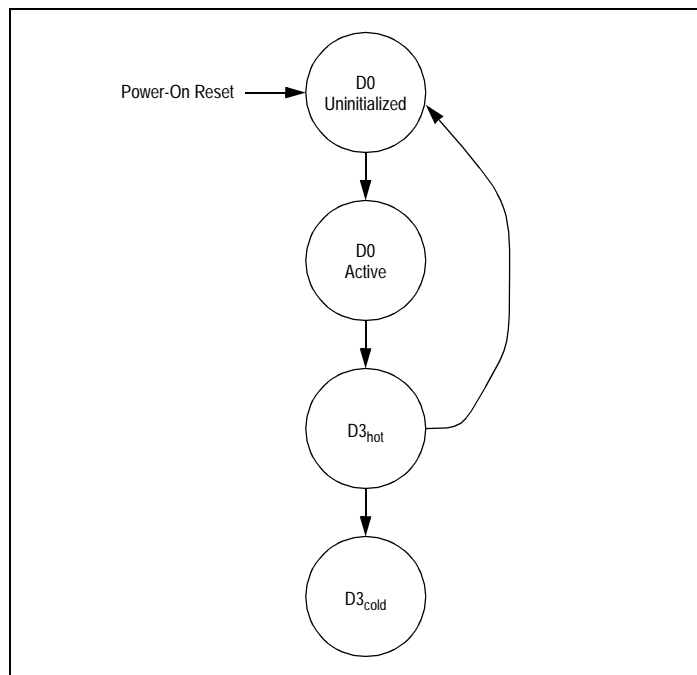

Figure 6.1 PES16T4G2 Power Management State Transition Diagram

## Notes

From State	To State	Description
any	D0 Uninitialized	Power-on Fundamental Reset.
D0 Uninitialized	D0 Active	PCI-PCI bridge configured by software
D0 Active	D3 <sub>hot</sub>	The Power Management State (PMSTATE) field in the PCI Power Management Control and Status (PMCSR) register is written with the value that corresponds to the D3 <sub>hot</sub> state.
D3 <sub>hot</sub>	D0 Uninitialized	The Power Management State (PMSTATE) field in the PCI Power Management Control and Status (PMCSR) register is written with the value that corresponds to D0 state.
D3 <sub>hott</sub>	D3 <sub>cold</sub>	Power is removed from the device.

**Table 6.1 PES16T4G2 Power Management State Transition Diagram**

The PES16T4G2 PCI-to-PCI bridges (i.e., ports) have the following behavior when in the D3<sub>hot</sub> power management state.

- A bridge accepts, processes and completes all type 0 configuration read and write requests.
- A bridge accepts and processes all message requests that target the bridge.
- All requests received by the bridge on the primary interface, except as noted above, are treated as unsupported requests (UR).
- Any error message resulting from the receipt of a TLP is reported in the same manner as when the bridge is not in D3<sub>hot</sub> (e.g, generation of an ERR\_NONFATAL message to the root).
- Error messages resulting from any event other than the receipt of a TLP are discarded (i.e., no error message is generated).
- All completions that target the bridge are treated as unexpected completions (UC).
- Completions flowing in either direction through the bridge are routed as normal. This behavior of the bridge does not differ from that of the bridge when it is in the D0 power management state.
- All request TLPs received on the secondary interface are treated as unsupported requests (UR).

## PME Messages

The PES16T4G2 does not support generation of PME messages from the D3<sub>cold</sub> state. Downstream ports (i.e., PCI-PCI bridges associated with downstream ports) support the generation of hot-plug PME events (i.e., a PM\_PME power management message) from the D3<sub>hot</sub> state. This includes both the case when the downstream port is in the D3<sub>hot</sub> state or the entire switch is in the D3<sub>hot</sub> state.

The generation of a PME message by downstream ports necessitates the implementation of a PME service time-out mechanism to ensure that PME messages are not lost. If the PME Status (PMES) bit in the a downstream port's PCI Power Management Control and Status (PMCSR) register is not cleared within the time-out period specified in the PM\_PME Time-Out (PMPMETO) field in the ports PM\_PME Timer (PMPMETIMER) register after a PM\_PME message is transmitted, then the PM\_PME message is retransmitted and the timer is restarted.

## PCI-Express Power Management Fence Protocol

Root complex takes the following steps to turn off power to a system.

- The root places all devices in the D3 state
- Upon entry to D3, all devices transition their links to the L1 state
- The root broadcasts a PME\_Turn\_Off message.
- Devices acknowledge the PME\_Turn\_Off message by returning a PME\_TO\_ACK message

## Notes

The PME\_Turn\_Off / PME\_TO\_Ack protocol may be initiated by the root when the switch is in any power management state.

When the PES16T4G2 receives a PME\_Turn\_Off message it broadcasts the PME\_Turn\_Off message on all active downstream ports. The PES16T4G2 transmits a PME\_TO\_Ack message on its upstream port and transitions its link state to L2/L3 Ready after it has received a PME\_TO\_Ack message on each of its active downstream ports. This process is called PME\_TO\_Ack aggregation.

The aggregation of PME\_TO\_Ack messages on downstream ports is abandoned by the PES16T4G2 when it receives a TLP on its upstream port after it has received a PME\_Turn\_Off message on that port but before it has responded with a PME\_TO\_Ack message. Once a PME\_TO\_Ack message has been scheduled for transmission on the upstream port and the PME\_TO\_Ack aggregation process has completed, received TLPs at that point may be discarded.

If the TLP that causes PME\_TO\_Ack aggregation to be abandoned targets the PES16T4G2, then the PES16T4G2 responds to the TLP normally. If the TLP that causes aggregation to be abandoned targets a downstream port and the port is in L0, then the TLP is transmitted on the downstream port. If the downstream port is not in L0 (i.e., it is in L2/L3 Ready), then the switch transitions the link to Detect and then to L0. Once the link reaches L0, the TLP is transmitted on the downstream port.

When PME\_TO\_Ack aggregation is abandoned, the PES16T4G2 makes no attempt to abandon the PME\_Turn\_Off and PME\_TO\_Ack protocol on downstream ports. Devices downstream of the PES16T4G2 are allowed to respond with a PME\_TO\_Ack and transition to L2/L3 Ready. When a TLP is received that targets the downstream port, then the switch transitions the link to Detect and then to L0. Once the link reaches L0, the TLP is transmitted on the downstream port.

In order to avoid deadlock, a downstream port that does not receive a PME\_TO\_Ack message in the time-out period specified in the PME\_TO\_Ack Time-Out (PMETOATO) field in its corresponding PME\_TO\_Ack Timer (PMETOATIMER) register, declares a time-out, transitions its link to L2/L3 Ready and signals to the upstream port that a PME\_TO\_Ack message has been received. If instead of being transitioned to the D3<sub>cold</sub> state, the PES16T4G2 is transitioned to the D0<sub>uninitialized</sub> state, then the PES16T4G2 resumes generation of PM\_PME messages.

## Power Budgeting Capability

The PES16T4G2 contains the mechanisms necessary to implement the PCI-Express power budgeting enhanced capability. However, by default, these mechanisms are not enabled. To enable the power budgeting capability, registers in this capability should be initialized and the Next Pointer (NXTPTR) field in one of the other enhanced capabilities should be initialized to point to the power budgeting capability. The Next Pointer (NXTPTR) of the power budgeting capability should be adjusted if necessary.

The power budgeting capability consists of the four power budgeting capability registers defined in the PCIe 2.0 base specification and eight general purpose read-write registers. See Chapter 8, Power Budgeting Enhanced Capability on page 8-52 for a description of these registers.

The Power Budgeting Capabilities (PWRBCAP) register contains the PCI-Express enhanced capability header for the power budgeting capability. By default, this register has an initial read-only value of zero. To enable the power budgeting capability, this register should be initialized via the serial EEPROM. The Power Budgeting Data Value [0..7] (PWRBDV[0..7]) registers are used to hold the power budgeting information for that port in a particular operating condition.

The PWRBDV registers may be read and written when the Power Budgeting Data Value Unlock (PWRBDVUL) bit is set in the Switch Control (SWCTL) register. When the PWRBDVUL bit is cleared, these registers are read-only and writes to these registers are ignored. To enable the power budgeting capability, the PWRBDV registers should be initialized with power budgeting information via the serial EEPROM.

Notes





# Hot-Plug and Hot-Swap

## Notes

### Hot-Plug

As illustrated in Figures 7.1 through 7.3, a PCIe switch may be used in one of three hot-plug configurations. Figure 7.1 illustrates the use of the PES16T4G2 in an application in which two downstream ports are connected to slots into which add-in cards may be hot-plugged. Figure 7.2 illustrates the use of the PES16T4G2 in an add-in card application. Here the downstream ports are hardwired to devices on the add-in card and the upstream port serves as the add-in card's PCIe interface. In this application the upstream port may be hot-plugged into a slot on the main system. Finally, Figure 7.3 illustrates the use of the PES16T4G2 in a carrier card application. In this application, the downstream ports are connected to slots which may be hot-plugged and the entire assembly may be hot-plugged into a slot on the main system. Since this application requires nothing more than the functionality illustrated in both Figures 7.1 through 7.2, it will not be discussed further.

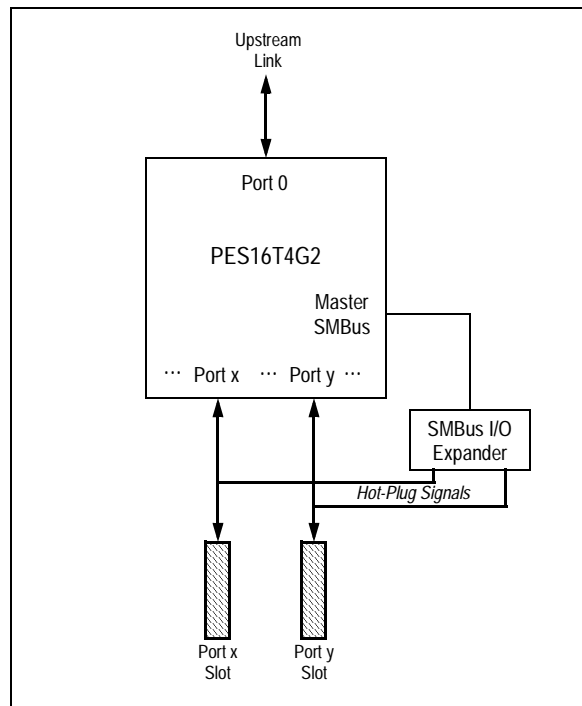

Figure 7.1 Hot-Plug on Switch Downstream Slots Application

Notes

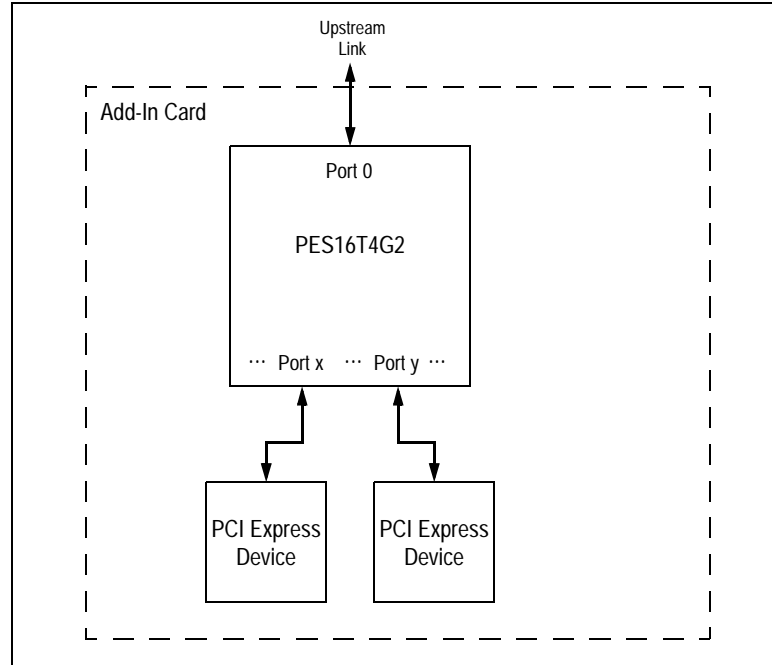

Figure 7.2 Hot-Plug with Switch on Add-In Card Application

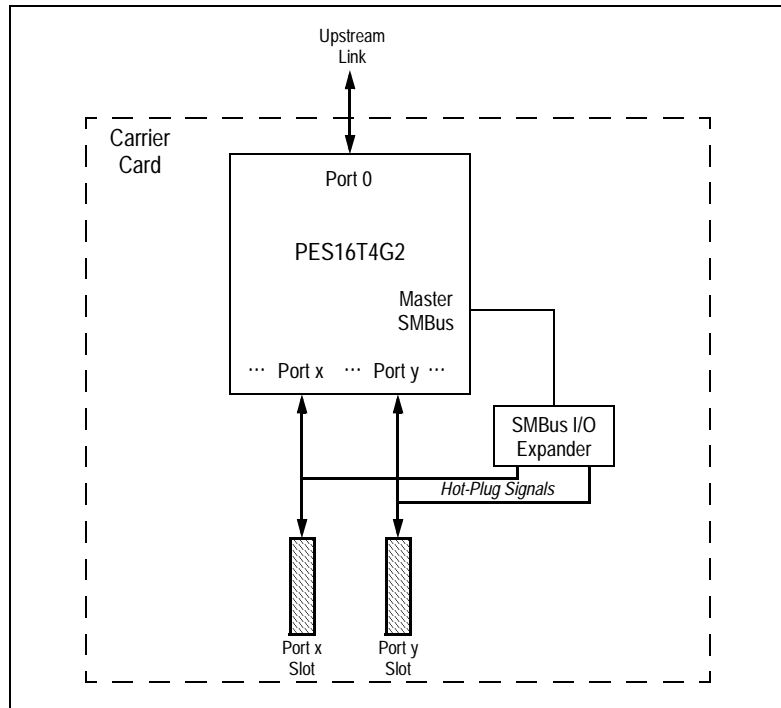

Figure 7.3 Hot-Plug with Carrier Card Application

The PCI-Express Base Specification revision 1.0a allowed a hot-plug attention indicator, power indicator and attention button to be located on the board on which the slot is implemented or on the add-in board. When located on the add-in board, state changes are communicated between the hot-plug controller associated with the slot and the add-in card via hot-plug messages. This capability was removed starting with revision 1.1 of the PCI Express Base Specification and is not supported in the PES16T4G2.

## Notes

The remainder of this section discusses the use of the PES16T4G2 in an application in which one or more of the downstream ports are used in an application in which an add-in card may be hot-plugged into a downstream slot. Associated with each downstream port in the PES16T4G2 is a hot-plug controller. The hot-plug controller may be enabled by setting the HPC bit in the PCI Express Slot Capabilities (PCIESCAP) register associated with that port during configuration (e.g., via serial EEPROM). The PES16T4G2 allows sensor inputs and indicator outputs to be located next to the slot or on the plug-in module. Regardless of the physical location, the indicators are controlled by the PES16T4G2's downstream port.

Table 7.1 lists the hot-plug inputs and outputs that may be associated with a slot. When enabled during configuration in the PCIESCAP register, these inputs and outputs are made available to external logic using an external I/O expander located on the master SMBus interface.

When the IO Expander is initialized (i.e., the HPC bit in the port's PCIESCAP register transitions from 0 to 1, or the IOEXPADDR field in the IOEXPADDR0/1 registers is written to), the hot-plug controller for the corresponding port initiates an SMBus access to configure the IO Expander and updates the status bits in the PCI Express Slot Status (PCIESSTS) register. During this initial access, the Presence Detect Changed (PDC) and MRL Sensor Changed (MRLSC) bits in the PCIESSTS register are not set, since this access is used to determine the initial state of the IO Expander signals.

By default, the PES16T4G2 supports presence detect signalling via assertion of the Presence Detect Input signal in the external I/O Expander module and through "in-band" presence detect. The Presence Detect Control (PDETECT) field in the Hot-Plug Configuration Control (HPCFGCTL) register may be used to control the mechanism used for presence detect.

Signal	Type	Name/Description
PxAPN	I	Port x <sup>1</sup> Attention Push button Input.
PxPDN	I	Port x Presence Detect Input.
PxPFN	I	Port x Power Fault Input.
PxMRLN	I	Port x Manually-operated Retention Latch (MRL) Input.
PxAIn	O	Port x Attention Indicator Output.
PxPIN	O	Port x Power Indicator Output.
PxPEP	O	Port x Power Enable Output.
PxILOCKP	O	Port x Electromechanical Interlock.
PxPWRGDN	I	Port x Power Good Input (asserted when slot power is good).
PxRSTN <sup>2</sup>	O	Port x Reset Output.

**Table 7.1 Downstream Port Hot Plug Signals**

<sup>1</sup> x corresponds to downstream port number (i.e., 2, 4, and 6).

<sup>2</sup> This signal is a GPIO pin alternate function and is not available as an I/O expander output.

Since the polarity of hot-plug signals has been defined differently in various specifications, each hot plug signal has a corresponding control bit in the Hot-Plug Configuration Control (HPCFGCTL) that allows the polarity of that signal to be inverted. Inversion affects the corresponding signal in all ports. When a one is written to the EIC bit in the PCIESCTL register, the PxILOCKP signal is pulsed with a pulse length greater than 100 ms and less than 150 ms (i.e., it transitions from negated to asserted, maintains an asserted state for 100 to 150 ms, and then transitions back to negated). When the Toggle Electromechanical Interlock Control (TEMICL) bit in the HPCFGCTL register is set, writing a one to the EIC bit inverts the state of the PxILOCKP signal.

When the Replace MRL Status with EMIL Status (RMRLWEMIL) bit is set in the HPCFGCTL register, the port's PxMRLN input is used as the electromechanical state input. The state of this input is used as the state of the electromechanical interlock state obtained by reading the Electromechanical Interlock Status

## Notes

(EIS) bit in the PCI Express Slot Status (PCIESSTS) register. In this mode the state of the Manually-operated Retention Latch Sensor State (MRLSS) status is always reported as closed (i.e., zero). When the RMRLWEMIL bit is cleared, the EIS bit state in the PCIESSTS register always returns the value of corresponding PxlLOCKP I/O expander signal output.

When the MRL Automatic Power Off (MRLPWROFF) bit is set in the HPCFGCTL register and the Manual Retention Latch Present (MRLP) bit is set in the PCI Express Slot Capability (PCIESCAP) register, then power to the slot is automatically turned off when the MRL sensor indicates that the MRL is open. This occurs regardless of the state of the Power Controller Control (PCC) bit in the PCI Express Slot Control (PCIESCTL) register.

The state of a port's Power Fault (PxPFN) input is not latched by the PES16T4G2. For proper operation the system designer should ensure that once the PxPFN signal is asserted, it remains asserted until the power enable (PxPEP) signal is toggled. This is required adapter behavior for the PCI Express Express-Module form factor. Downstream port reset outputs are described in section Downstream Port Reset Outputs on page 2-7 .

The default value of hot-plug registers following a Hot-Reset or Fundamental Reset may be configured via serial EEPROM initialization. Since hot-plug I/O expander initialization occurs after serial EEPROM initialization, the Command Completed (CC) bit is not set in the PCI Express Slot Status (PCIESSTS) register as a result of serial EEPROM initialization.

#### Hot-Plug I/O Expander

The PES16T4G2 utilizes external SMBus/I2C-bus I/O expanders connected to the master SMBus interface for hot-plug related signals associated with downstream ports. See section I/O Expanders on page 5-6 for details on the operation of the I/O expanders and for the mapping of downstream hot-plug signals to I/O expander inputs and outputs.

#### Hot-Plug Interrupts and Wake-up

The hot-plug controller associated with a downstream slot may generate an interrupt or wake-up event. Hot-plug interrupts are only generated when the Hot Plug Interrupt Enable (HPIE) bit is set in the corresponding port's PCI Express Slot Control (PCIESCTL) register.

The following bits, when set in the PCI Express Slot Status (PCIESSTS) register, generate an interrupt if not masked by the corresponding bit in the PCI Express Slot Control (PCIESCTL) register or by the HPIE bit: the Attention Button Pressed (ABP), Power Fault Detected (PFD), MRL Sensor Changed (MRLSC), Presence Detected Changed (PDC), and Command Completed (CC).

When an unmasked hot-plug interrupt is generated, the action taken is determined by the MSI Enable (EN) bit in the MSI Capability (MSICAP) register and the Interrupt Disable (INTXD) bit in the PCI Command (PCICMD) register. When the downstream port or the entire switch is in a D3<sub>hot</sub> state, the hot-plug controller generates a wake-up event using a PM\_PME message instead of an interrupt if the event interrupt is not masked in the slot control (PCIESCTL) register and hot-plug interrupts are disabled by the HPIE bit. If the event interrupt is not masked and hot-plug interrupts are enabled, both a PM\_PME and an interrupt are generated. If the event interrupt is masked, neither a PM\_PME nor an interrupt is generated. Note that a command completed (CC bit) interrupt will not generate a wakeup event.

#### Legacy System Hot-Plug Support

Some systems require support for operating systems that lack PCIe hot-plug support. The PES16T4G2 supports these systems by providing a General Purpose Event (GPEN) output as an alternate function of GPIO[7] that can be used instead of the INTx, MSI, and PME mechanisms defined by PCI Express hot-plug.

Associated with each downstream port's hot-plug controller is a bit in the General Purpose Event Control (PO\_GPECTL) register. When this bit is set, the corresponding PCIe base 2.0 hot plug event notification mechanisms are disabled for that port and INTx, MSI, and PME events will not be generated by that port due to hot-plug events. Instead, hot-plug events are signaled through assertion of the GPEN signal.

## Notes

GPEN is an alternate function of GPIO[7] and GPIO[7] will not be asserted when GPEN is asserted unless it is configured to operate as an alternate function. Whenever a port signals a hot-plug event through assertion of the GPEN signal, the corresponding port's status bit in the General Purpose Event Status (P0\_GPESTS) register is set. A bit in the P0\_GPESTS register can only be set if the corresponding port's hot plug controller is configured to signal hot-plug events using the general purpose event (GPEN) signal assertion mechanism.

The hot-plug event signalling mechanism is the only thing that is affected when a port is configured to use general purpose events instead of the PCIe defined hot-plug signalling mechanisms (i.e., INTx, MSI and PME). Thus, the PCIe defined capability, status and mask bits defined in the PCIe slot capabilities, status and control registers operate as normal and all other hot-plug functionality associated with the port remains unchanged. INTx, MSI and PME events from other sources are also unaffected.

The enhanced hot-plug signalling mechanism supported by the PES16T4G2 is graphically illustrated in Figure 7.4. This figure provides a conceptual summary of the enhanced hot-plug signalling mechanism in the form of a pseudo logic diagram. Logic gates in this diagram are intended for conveying general concepts, and not for direct implementation.

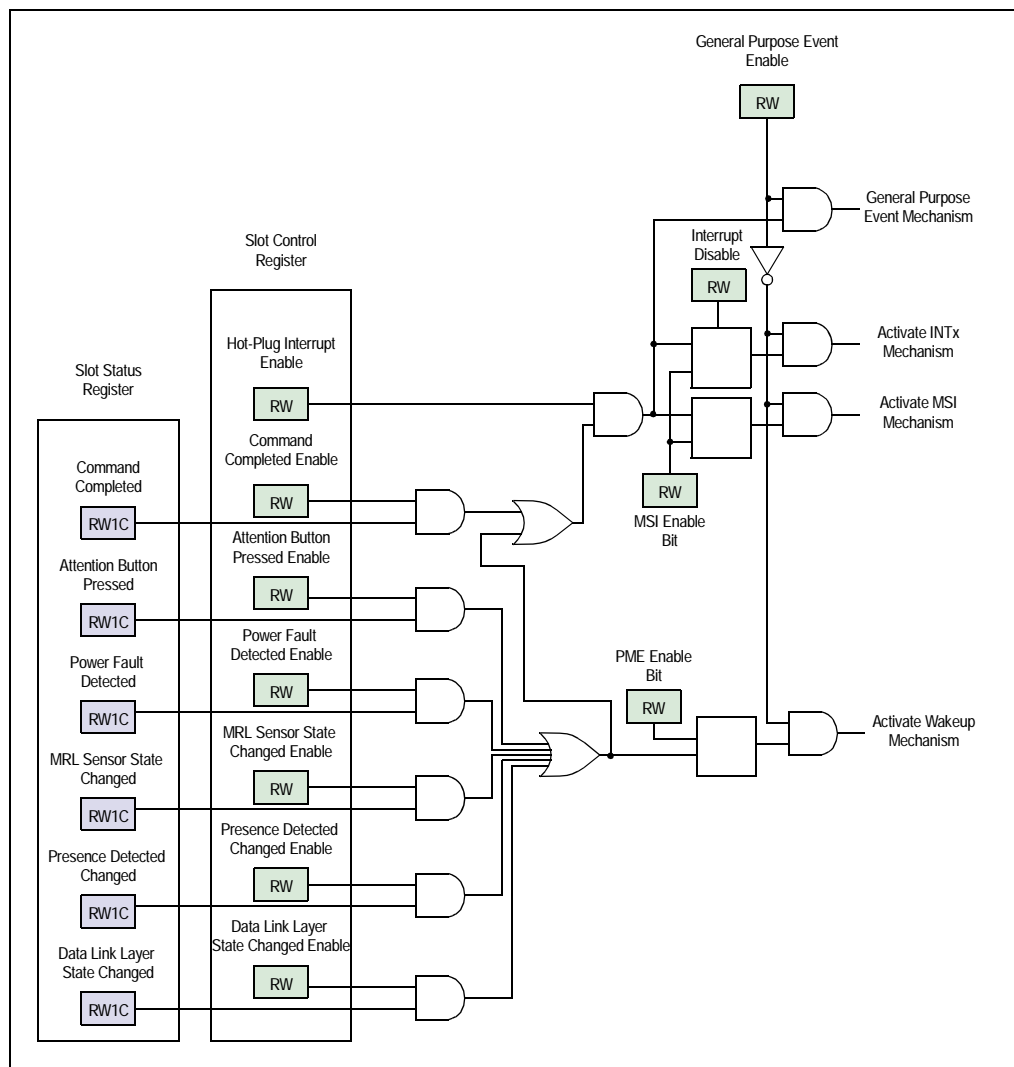

Figure 7.4 PES16T4G2 Hot-Plug Event Signalling

## Notes

## Hot-Swap

- ◆ PES16T4G2 is hot-swap capable and meets the following requirements
  - All of the I/Os are tri-stated on reset (i.e., SerDes, GPIO, SMBuses, etc.)
  - All I/O cells function predictably from early power. This means that the device is able to tolerate a non-monotonic ramp-up as well as a rapid ramp-up of the DC power.
  - All I/O cells are able to tolerate a precharge voltage
  - Since no clock is present during physical connection, the device will maintain all outputs in a high-impedance state even when no clock is present.
  - The I/O cells meet VI requirements for hot-swap.
  - The I/O cells respect the required leakage current limits over the entire input voltage range.
- ◆ In summary, the PES16T4G2 meets all of the I/O requirements necessary to build a PICMG compliant hot-swap board or system.
- ◆ The hot-swap I/O buffers of the PES16T4G2 may also be used to construct proprietary hot-swap systems.
- ◆ See the PES16T4G2 Data Sheet at [www.idt.com](http://www.idt.com) for a detailed specification of I/O buffer characteristics.



# Configuration Registers

## Notes

### Configuration Space Organization

Each software visible register in the PES16T4G2 is contained in the PCI configuration space of one of the ports. Thus, there are no registers in the PES16T4G2 that cannot be accessed by the root. Each software visible register in the PES16T4G2 has a system address. The system address is formed by adding the PCI configuration space offset value of the register to the base address of the port in which it is located. The system address is used for serial EEPROM register initialization and slave SMBus register accesses.

The base address for each PES16T4G2 port is listed in Table 8.1. The PCI configuration space offset addresses for registers in the upstream port are listed in Table 8.2 while the PCI configuration space offset addresses for registers in downstream ports are listed Table 8.3.

Base Address	PCI Configuration Space
0x0000	Port 0 configuration space (upstream port)
0x2000	Port 2 configuration space (downstream port)
0x4000	Port 4 configuration space (downstream port)
0x6000	Port 6 configuration space (downstream port)

**Table 8.1 Base Addresses for Port Configuration Space Registers**

As shown in Figure 8.1, upstream and downstream ports share a similar PCI configuration space register layout.

- The upstream port contains global switch control and status registers as well as test mode registers which are not present in the configuration space of downstream ports.
- Due the ability to generate MSIs as a result of hot-plug events, the downstream ports contain an MSI capability structure which is not present in the upstream port.

Reading from an upstream port offset not defined in Table 8.2 or a downstream offset not defined in Table 8.3 returns a value of zero. Writes to such an offset complete successfully but modify no data and have no other effect.

Software visible configuration registers exist with one or more fields that perform a side-effect action when written. These side-effect actions may affect the ability of the switch to respond with a completion. For example, writing a one to the Hot Reset (HRST) bit in the Switch Control (SWCTL) register initiates a hot reset of the entire switch. Other examples are the FRST bit in SWCTL, the Link-Disable (LDIS) and Link-Retrain (LRET) bits in the PCI Express Link Control register, as well as the Full Link Retrain (FLRET) field that in the PHY Link State 0 (PHYLSTATE0) register. A configuration write to such a register returns a completion to the Root before the side-effect action is performed. This is implemented by delaying the side-effect action by 1 ms following generation of the completion. Thus, if the completion is not accepted by the upstream port link partner in this time interval, then the completion will be lost.

Notes

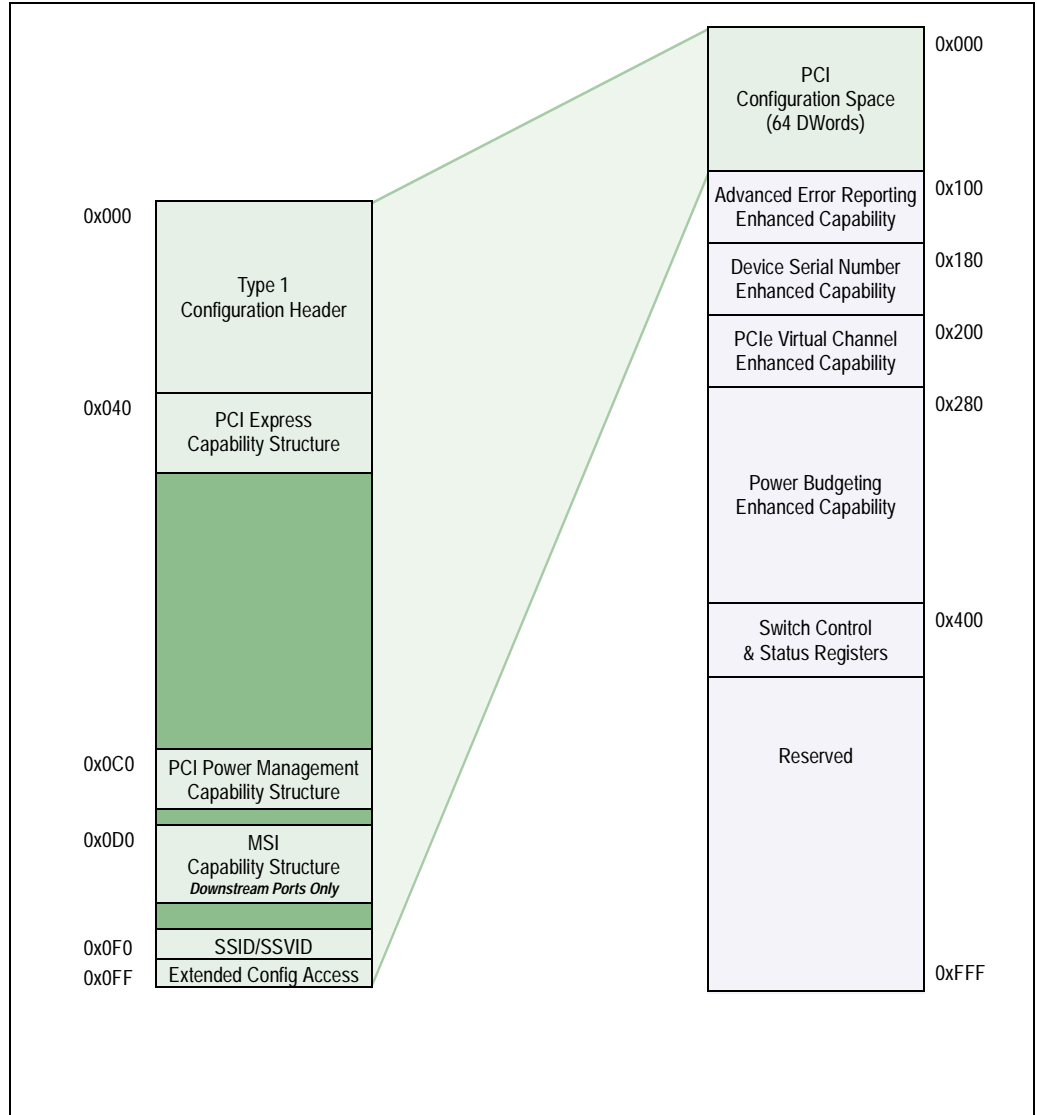

Figure 8.1 Port Configuration Space Organization



## Notes

## Upstream Port (Port 0)

Cfg. Offset	Size	Register Mnemonic	Register Definition
0x000	Word	P0_VID	VID - Vendor Identification Register (0x000) on page 8-10
0x002	Word	P0_DID	DID - Device Identification Register (0x002) on page 8-10
0x004	Word	P0_PCICMD	PCICMD - PCI Command Register (0x004) on page 8-10
0x006	Word	P0_PCISTS	PCISTS - PCI Status Register (0x006) on page 8-11
0x008	Byte	P0_RID	RID - Revision Identification Register (0x008) on page 8-12
0x009	3 Bytes	P0_CCODE	CCODE - Class Code Register (0x009) on page 8-12
0x00C	Byte	P0_CLS	CLS - Cache Line Size Register (0x00C) on page 8-12
0x00D	Byte	P0_PLTIMER	PLTIMER - Primary Latency Timer (0x00D) on page 8-12
0x00E	Byte	P0_HDR	HDR - Header Type Register (0x00E) on page 8-13
0x00F	Byte	P0_BIST	BIST - Built-in Self Test Register (0x00F) on page 8-13
0x010	DWord	P0_BAR0	BAR0 - Base Address Register 0 (0x010) on page 8-13
0x014	DWord	P0_BAR1	BAR1 - Base Address Register 1 (0x014) on page 8-13
0x018	Byte	P0_PBUSN	PBUSN - Primary Bus Number Register (0x018) on page 8-13
0x019	Byte	P0_SBUSN	SBUSN - Secondary Bus Number Register (0x019) on page 8-13
0x01A	Byte	P0_SUBBUSN	SUBBUSN - Subordinate Bus Number Register (0x01A) on page 8-14
0x01B	Byte	P0_SLTIMER	SLTIMER - Secondary Latency Timer Register (0x01B) on page 8-14
0x01C	Byte	P0_IOBASE	IOBASE - I/O Base Register (0x01C) on page 8-14
0x01D	Byte	P0_IOLIMIT	IOLIMIT - I/O Limit Register (0x01D) on page 8-14
0x01E	Word	P0_SECSTS	SECSTS - Secondary Status Register (0x01E) on page 8-15
0x020	Word	P0_MBASE	MBASE - Memory Base Register (0x020) on page 8-15
0x022	Word	P0_MLIMIT	MLIMIT - Memory Limit Register (0x022) on page 8-15
0x024	Word	P0_PMBASE	PMBASE - Prefetchable Memory Base Register (0x024) on page 8-16
0x026	Word	P0_PMLIMIT	PMLIMIT - Prefetchable Memory Limit Register (0x026) on page 8-16
0x028	DWord	P0_PMBASEU	PMBASEU - Prefetchable Memory Base Upper Register (0x028) on page 8-16
0x02C	DWord	P0_PMLIMITU	PMLIMITU - Prefetchable Memory Limit Upper Register (0x02C) on page 8-17
0x030	Word	P0_IOBASEU	IOBASEU - I/O Base Upper Register (0x030) on page 8-17
0x032	Word	P0_IOLIMITU	IOLIMITU - I/O Limit Upper Register (0x032) on page 8-17
0x034	Byte	P0_CAPPTR	CAPPTR - Capabilities Pointer Register (0x034) on page 8-17
0x038	DWord	P0_EROMBASE	EROMBASE - Expansion ROM Base Address Register (0x038) on page 8-17
0x03C	Byte	P0_INTRLINE	INTRLINE - Interrupt Line Register (0x03C) on page 8-18
0x03D	Byte	P0_INTRPIN	INTRPIN - Interrupt PIN Register (0x03D) on page 8-18
0x03E	Word	P0_BCTL	BCTL - Bridge Control Register (0x03E) on page 8-18

Table 8.2 Upstream Port 0 Configuration Space Registers (Part 1 of 4)

## Notes

Cfg. Offset	Size	Register Mnemonic	Register Definition
0x040	DWord	P0_PCIECAP	PCIECAP - PCI Express Capability (0x040) on page 8-19
0x044	DWord	P0_PCIEDCAP	PCIEDCAP - PCI Express Device Capabilities (0x044) on page 8-20
0x048	Word	P0_PCIECTL	PCIEDCTL - PCI Express Device Control (0x048) on page 8-21
0x04A	Word	P0_PCIESTSTS	PCIEDSTS - PCI Express Device Status (0x04A) on page 8-22
0x04C	DWord	P0_PCIELCAP	PCIELCAP - PCI Express Link Capabilities (0x04C) on page 8-23
0x050	Word	P0_PCIELCTL	PCIELCTL - PCI Express Link Control (0x050) on page 8-24
0x052	Word	P0_PCIELSTS	PCIELSTS - PCI Express Link Status (0x052) on page 8-26
0x064	DWord	P0_PCIEDCAP2	PCIEDCAP2 - PCI Express Device Capabilities 2 (0x064) on page 8-31
0x068	Word	P0_PCIECTL2	PCIEDCTL2 - PCI Express Device Control 2 (0x068) on page 8-31
0x06A	Word	P0_PCIESTSTS2	PCIEDSTS2 - PCI Express Device Status 2 (0x06A) on page 8-32
0x06C	DWord	P0_PCIELCAP2	PCIELCAP2 - PCI Express Link Capabilities 2 (0x06C) on page 8-32
0x070	Word	P0_PCIELCTL2	PCIELCTL2 - PCI Express Link Control 2 (0x070) on page 8-32
0x072	Word	P0_PCIELSTS2	PCIELSTS2 - PCI Express Link Status 2 (0x072) on page 8-34
0x0C0	DWord	P0_PMCAP	PMCAP - PCI Power Management Capabilities (0x0C0) on page 8-34
0x0C4	DWord	P0_PMCSR	PMCSR - PCI Power Management Control and Status (0x0C4) on page 8-35
0x0D0 - 0x0DC			Reserved
0x0F0	Dword	P0_SSIDSSVIDCAP	SSIDSSVIDCAP - Subsystem ID and Subsystem Vendor ID Capability (0x0F0) on page 8-37
0x0F4	Dword	P0_SSIDSSVID	SSIDSSVID - Subsystem ID and Subsystem Vendor ID (0x0F4) on page 8-38
0x0F8	Dword	P0_ECFGADDR	ECFGADDR - Extended Configuration Space Access Address (0x0F8) on page 8-38
0x0FC	Dword	P0_ECFGDATA	ECFGDATA - Extended Configuration Space Access Data (0x0FC) on page 8-38
0x100	Dword	P0_AERCAP	AERCAP - AER Capabilities (0x100) on page 8-39
0x104	Dword	P0_AERUES	AERUES - AER Uncorrectable Error Status (0x104) on page 8-39
0x108	Dword	P0_AERUEM	AERUEM - AER Uncorrectable Error Mask (0x108) on page 8-40
0x10C	Dword	P0_AERUESV	AERUESV - AER Uncorrectable Error Severity (0x10C) on page 8-42
0x110	Dword	P0_AERCES	AERCES - AER Correctable Error Status (0x110) on page 8-43
0x114	Dword	P0_AERCEM	AERCEM - AER Correctable Error Mask (0x114) on page 8-44
0x118	Dword	P0_AERCTL	AERCTL - AER Control (0x118) on page 8-44
0x11C	Dword	P0_AERHL1DW	AERHL1DW - AER Header Log 1st Doubleword (0x11C) on page 8-45
0x120	Dword	P0_AERHL2DW	AERHL2DW - AER Header Log 2nd Doubleword (0x120) on page 8-45
0x124	Dword	P0_AERHL3DW	AERHL3DW - AER Header Log 3rd Doubleword (0x124) on page 8-45
0x128	Dword	P0_AERHL4DW	AERHL4DW - AER Header Log 4th Doubleword (0x128) on page 8-45
0x180	Dword	P0_SNUMCAP	SNUMCAP - Serial Number Capabilities (0x180) on page 8-45

Table 8.2 Upstream Port 0 Configuration Space Registers (Part 2 of 4)

## Notes

Cfg. Offset	Size	Register Mnemonic	Register Definition
0x184	Dword	P0_SNUMLDW	SNUMLDW - Serial Number Lower Doubleword (0x184) on page 8-45
0x188	Dword	P0_SNUMUDW	SNUMUDW - Serial Number Upper Doubleword (0x188) on page 8-46
0x200	DWord	P0_PCIEVCECAP	PCIEVCECAP - PCI Express VC Enhanced Capability Header (0x200) on page 8-46
0x204	DWord	P0_PVCCAP1	PVCCAP1- Port VC Capability 1 (0x204) on page 8-46
0x208	DWord	P0_PVCCAP2	PVCCAP2- Port VC Capability 2 (0x208) on page 8-47
0x20C	Word	P0_PVCCTL	PVCCTL - Port VC Control (0x20C) on page 8-47
0x20E	Word	P0_PVCSTS	PVCSTS - Port VC Status (0x20E) on page 8-47
0x210	DWord	P0_VCR0CAP	VCR0CAP- VC Resource 0 Capability (0x210) on page 8-48
0x214	DWord	P0_VCR0CTL	VCR0CTL- VC Resource 0 Control (0x214) on page 8-48
0x218	DWord	P0_VCR0STS	VCR0STS - VC Resource 0 Status (0x218) on page 8-49
0x220	DWord	P0_VCR0TBL0	VCR0TBL0 - VC Resource 0 Arbitration Table Entry 0 (0x220) on page 8-50
0x224	DWord	P0_VCR0TBL1	VCR0TBL1 - VC Resource 0 Arbitration Table Entry 1 (0x224) on page 8-50
0x228	DWord	P0_VCR0TBL2	VCR0TBL2 - VC Resource 0 Arbitration Table Entry 2 (0x228) on page 8-51
0x22C	DWord	P0_VCR0TBL3	VCR0TBL3 - VC Resource 0 Arbitration Table Entry 3 (0x22C) on page 8-51
0x280	Dword	P0_PWRBCAP	PWRBCAP - Power Budgeting Capabilities (0x280) on page 8-52
0x284	Dword	P0_PWRBDSEL	PWRBDSEL - Power Budgeting Data Select (0x284) on page 8-52
0x288	Dword	P0_PWRBD	PWRBD - Power Budgeting Data (0x288) on page 8-52
0x28C	Dword	P0_PWRBPBC	PWRBPBC - Power Budgeting Power Budget Capability (0x28C) on page 8-53
0x300	Dword	P0_PWRBDV0	PWRBDV[7:0] - Power Budgeting Data Value [7:0] (0x300 - 0X31C) on page 8-53
0x304	Dword	P0_PWRBDV1	PWRBDV[7:0] - Power Budgeting Data Value [7:0] (0x300 - 0X31C) on page 8-53
0x308	Dword	P0_PWRBDV2	PWRBDV[7:0] - Power Budgeting Data Value [7:0] (0x300 - 0X31C) on page 8-53
0x30C	Dword	P0_PWRBDV3	PWRBDV[7:0] - Power Budgeting Data Value [7:0] (0x300 - 0X31C) on page 8-53
0x310	Dword	P0_PWRBDV4	PWRBDV[7:0] - Power Budgeting Data Value [7:0] (0x300 - 0X31C) on page 8-53
0x314	Dword	P0_PWRBDV5	PWRBDV[7:0] - Power Budgeting Data Value [7:0] (0x300 - 0X31C) on page 8-53
0x318	Dword	P0_PWRBDV6	PWRBDV[7:0] - Power Budgeting Data Value [7:0] (0x300 - 0X31C) on page 8-53
0x31C	Dword	P0_PWRBDV7	PWRBDV[7:0] - Power Budgeting Data Value [7:0] (0x300 - 0X31C) on page 8-53
0x400	DWord	SWSTS	SWSTS - Switch Status (0x400) on page 8-53

Table 8.2 Upstream Port 0 Configuration Space Registers (Part 3 of 4)

## Notes

Cfg. Offset	Size	Register Mnemonic	Register Definition
0x404	DWord	SWCTL	SWCTL - Switch Control (0x404) on page 8-54
0x408	DWord	HPCFGCTL	HPCFGCTL - Hot-Plug Configuration Control (0x408) on page 8-55
0x418	DWord	GPIOFUNC	GPIOFUNC - General Purpose I/O Control Function (0x418) on page 8-56
0x41C	DWord	GPIOCFG	GPIOCFG - General Purpose I/O Configuration (0x41C) on page 8-56
0x420	DWord	GPIOD	GPIOD - General Purpose I/O Data (0x420) on page 8-56
0x424	DWord	SMBUSSTS	SMBUSSTS - SMBus Status (0x424) on page 8-57
0x428	DWord	SMBUSCTL	SMBUSCTL - SMBus Control (0x428) on page 8-57
0x42C	DWord	EEPROMINTF	EEPROMINTF - Serial EEPROM Interface (0x42C) on page 8-58
0x434	DWord	IOEXPADDR0	IOEXPADDR0 - SMBus I/O Expander Address 0 (0x434) on page 8-59
0x438	DWord	IOEXPADDR1	IOEXPADDR1 - SMBus I/O Expander Address 1 (0x438) on page 8-59
0x450	DWord	GPECTL	GPECTL - General Purpose Event Control (0x450) on page 8-59
0x454	DWord	GPESTS	GPESTS - General Purpose Event Status (0x454) on page 8-60
0x500	Dword	P0_SERDESCCTL	SERDESCCTL - SerDes Control (0x500) on page 8-60
0x534	Dword	P0_PHYLSTATE0	PHYLSTATE0 - Phy Link State 0 (0x534) on page 8-61

Table 8.2 Upstream Port 0 Configuration Space Registers (Part 4 of 4)

## Downstream Ports

Cfg. Offset	Size	Register Mnemonic	Register Definition
0x000	Word	Px_VID	VID - Vendor Identification Register (0x000) on page 8-10
0x002	Word	Px_DID	DID - Device Identification Register (0x002) on page 8-10
0x004	Word	Px_PCICMD	PCICMD - PCI Command Register (0x004) on page 8-10
0x006	Word	Px_PCISTS	PCISTS - PCI Status Register (0x006) on page 8-11
0x008	Byte	Px_RID	RID - Revision Identification Register (0x008) on page 8-12
0x009	3 Bytes	Px_CCODE	CCODE - Class Code Register (0x009) on page 8-12
0x00C	Byte	Px_CLS	CLS - Cache Line Size Register (0x00C) on page 8-12
0x00D	Byte	Px_PLTIMER	PLTIMER - Primary Latency Timer (0x00D) on page 8-12
0x00E	Byte	Px_HDR	HDR - Header Type Register (0x00E) on page 8-13
0x00F	Byte	Px_BIST	BIST - Built-in Self Test Register (0x00F) on page 8-13
0x010	DWord	Px_BAR0	BAR0 - Base Address Register 0 (0x010) on page 8-13
0x014	DWord	Px_BAR1	BAR1 - Base Address Register 1 (0x014) on page 8-13
0x018	Byte	Px_PBUSN	PBUSN - Primary Bus Number Register (0x018) on page 8-13
0x019	Byte	Px_SBUSN	SBUSN - Secondary Bus Number Register (0x019) on page 8-13
0x01A	Byte	Px_SUBBUSN	SUBBUSN - Subordinate Bus Number Register (0x01A) on page 8-14
0x01B	Byte	Px_SLTIMER	SLTIMER - Secondary Latency Timer Register (0x01B) on page 8-14

Table 8.3 Downstream Ports 2, 4, 6 Configuration Space Registers (Part 1 of 4)

## Notes

Cfg. Offset	Size	Register Mnemonic	Register Definition
0x01C	Byte	Px_IOBASE	IOBASE - I/O Base Register (0x01C) on page 8-14
0x01D	Byte	Px_IOLIMIT	IOLIMIT - I/O Limit Register (0x01D) on page 8-14
0x01E	Word	Px_SECSTS	SECSTS - Secondary Status Register (0x01E) on page 8-15
0x020	Word	Px_MBASE	MBASE - Memory Base Register (0x020) on page 8-15
0x022	Word	Px_MLIMIT	MLIMIT - Memory Limit Register (0x022) on page 8-15
0x024	Word	Px_PMBASE	PMBASE - Prefetchable Memory Base Register (0x024) on page 8-16
0x026	Word	Px_PMLIMIT	PMLIMIT - Prefetchable Memory Limit Register (0x026) on page 8-16
0x028	DWord	Px_PMBASEU	PMBASEU - Prefetchable Memory Base Upper Register (0x028) on page 8-16
0x02C	DWord	Px_PMLIMITU	PMLIMITU - Prefetchable Memory Limit Upper Register (0x02C) on page 8-17
0x030	Word	Px_IOBASEU	IOBASEU - I/O Base Upper Register (0x030) on page 8-17
0x032	Word	Px_IOLIMITU	IOLIMITU - I/O Limit Upper Register (0x032) on page 8-17
0x034	Byte	Px_CAPPTR	CAPPTR - Capabilities Pointer Register (0x034) on page 8-17
0x038	DWord	Px_EROMBASE	EROMBASE - Expansion ROM Base Address Register (0x038) on page 8-17
0x03C	Byte	Px_INTRLINE	INTRLINE - Interrupt Line Register (0x03C) on page 8-18
0x03D	Byte	Px_INTRPIN	INTRPIN - Interrupt PIN Register (0x03D) on page 8-18
0x03E	Word	Px_BCTL	BCTL - Bridge Control Register (0x03E) on page 8-18
0x040	DWord	Px_PCIECAP	PCIECAP - PCI Express Capability (0x040) on page 8-19
0x044	DWord	Px_PCIEDCAP	PCIEDCAP - PCI Express Device Capabilities (0x044) on page 8-20
0x048	Word	Px_PCIECTL	PCIEDCTL - PCI Express Device Control (0x048) on page 8-21
0x04A	Word	Px_PCIEDSTS	PCIEDSTS - PCI Express Device Status (0x04A) on page 8-22
0x04C	DWord	Px_PCIELCAP	PCIELCAP - PCI Express Link Capabilities (0x04C) on page 8-23
0x050	Word	Px_PCIELCTL	PCIELCTL - PCI Express Link Control (0x050) on page 8-24
0x052	Word	Px_PCIELSTS	PCIELSTS - PCI Express Link Status (0x052) on page 8-26
0x054	DWord	Px_PCIESCAP	PCIESCAP - PCI Express Slot Capabilities (0x054) on page 8-27
0x058	Word	Px_PCIESCTL	PCIESCTL - PCI Express Slot Control (0x058) on page 8-29
0x05A	Word	Px_PCIESSTS	PCIESSTS - PCI Express Slot Status (0x05A) on page 8-30
0x064	DWord	Px_PCIEDCAP2	PCIEDCAP2 - PCI Express Device Capabilities 2 (0x064) on page 8-31
0x068	Word	Px_PCIEDCTL2	PCIEDCTL2 - PCI Express Device Control 2 (0x068) on page 8-31
0x06A	Word	Px_PCIEDSTS2	PCIEDSTS2 - PCI Express Device Status 2 (0x06A) on page 8-32
0x06C	DWord	Px_PCIELCAP2	PCIELCAP2 - PCI Express Link Capabilities 2 (0x06C) on page 8-32
0x070	Word	Px_PCIELCTL2	PCIELCTL2 - PCI Express Link Control 2 (0x070) on page 8-32
0x072	Word	Px_PCIELSTS2	PCIELSTS2 - PCI Express Link Status 2 (0x072) on page 8-34
0x074	DWord	Px_PCIESCAP2	PCIESCAP2 - PCI Express Slot Capabilities 2 (0x074) on page 8-34
0x078	Word	Px_PCIESCTL2	PCIESCTL2 - PCI Express Slot Control 2 (0x078) on page 8-34

Table 8.3 Downstream Ports 2, 4, 6 Configuration Space Registers (Part 2 of 4)

## Notes

Cfg. Offset	Size	Register Mnemonic	Register Definition
0x07A	Word	Px_PCIESSTS2	PCIESSTS2 - PCI Express Slot Status 2 (0x07A) on page 8-34
0x0C0	DWord	Px_PMCAP	PMCAP - PCI Power Management Capabilities (0x0C0) on page 8-34
0x0C4	DWord	Px_PMCSR	PMCSR - PCI Power Management Control and Status (0x0C4) on page 8-35
0x0D0	DWord	Px_MSICAP	MSICAP - Message Signaled Interrupt Capability and Control (0x0D0) on page 8-36
0x0D4	DWord	Px_MSIADDR	MSIADDR - Message Signaled Interrupt Address (0x0D4) on page 8-37
0x0D8	DWord	Px_MSUIADDR	MSUIADDR - Message Signaled Interrupt Upper Address (0x0D8) on page 8-37
0x0DC	DWord	Px_MSIMDATA	MSIMDATA - Message Signaled Interrupt Message Data (0x0DC) on page 8-37
0x0F0	Dword	Px_SSIDSSVIDCAP	SSIDSSVIDCAP - Subsystem ID and Subsystem Vendor ID Capability (0x0F0) on page 8-37
0x0F4	Dword	Px_SSIDSSVID	SSIDSSVID - Subsystem ID and Subsystem Vendor ID (0x0F4) on page 8-38
0x0F8	Dword	Px_ECFGADDR	ECFGADDR - Extended Configuration Space Access Address (0x0F8) on page 8-38
0x0FC	Dword	Px_ECFGDATA	ECFGDATA - Extended Configuration Space Access Data (0x0FC) on page 8-38
0x100	Dword	Px_AERCAP	AERCAP - AER Capabilities (0x100) on page 8-39
0x104	Dword	Px_AERUES	AERUES - AER Uncorrectable Error Status (0x104) on page 8-39
0x108	Dword	Px_AERUEM	AERUEM - AER Uncorrectable Error Mask (0x108) on page 8-40
0x10C	Dword	Px_AERUESV	AERUESV - AER Uncorrectable Error Severity (0x10C) on page 8-42
0x110	Dword	Px_AERCES	AERCES - AER Correctable Error Status (0x110) on page 8-43
0x114	Dword	Px_AERCEM	AERCEM - AER Correctable Error Mask (0x114) on page 8-44
0x118	Dword	Px_AERCTL	AERCTL - AER Control (0x118) on page 8-44
0x11C	Dword	Px_AERHL1DW	AERHL1DW - AER Header Log 1st Doubleword (0x11C) on page 8-45
0x120	Dword	Px_AERHL2DW	AERHL2DW - AER Header Log 2nd Doubleword (0x120) on page 8-45
0x124	Dword	Px_AERHL3DW	AERHL3DW - AER Header Log 3rd Doubleword (0x124) on page 8-45
0x128	Dword	Px_AERHL4DW	AERHL4DW - AER Header Log 4th Doubleword (0x128) on page 8-45
0x180	Dword	Px_SNUMCAP	SNUMCAP - Serial Number Capabilities (0x180) on page 8-45
0x184	Dword	Px_SNUMLDW	SNUMLDW - Serial Number Lower Doubleword (0x184) on page 8-45
0x188	Dword	Px_SNUMUDW	SNUMUDW - Serial Number Upper Doubleword (0x188) on page 8-46
0x200	DWord	Px_PCIEVCECAP	PCIEVCECAP - PCI Express VC Enhanced Capability Header (0x200) on page 8-46
0x204	DWord	Px_PVCCAP1	PVCCAP1- Port VC Capability 1 (0x204) on page 8-46
0x208	DWord	Px_PVCCAP2	PVCCAP2- Port VC Capability 2 (0x208) on page 8-47
0x20C	Word	Px_PVCCTL	PVCCTL - Port VC Control (0x20C) on page 8-47
0x20E	Word	Px_PVCSTS	PVCSTS - Port VC Status (0x20E) on page 8-47

Table 8.3 Downstream Ports 2, 4, 6 Configuration Space Registers (Part 3 of 4)

## Notes

Cfg. Offset	Size	Register Mnemonic	Register Definition
0x210	DWord	Px_VCR0CAP	VCR0CAP - VC Resource 0 Capability (0x210) on page 8-48
0x214	DWord	Px_VCR0CTL	VCR0CTL - VC Resource 0 Control (0x214) on page 8-48
0x218	DWord	Px_VCR0STS	VCR0STS - VC Resource 0 Status (0x218) on page 8-49
0x220	DWord	Px_VCR0TBL0	VCR0TBL0 - VC Resource 0 Arbitration Table Entry 0 (0x220) on page 8-50
0x224	DWord	Px_VCR0TBL1	VCR0TBL1 - VC Resource 0 Arbitration Table Entry 1 (0x224) on page 8-50
0x228	DWord	Px_VCR0TBL2	VCR0TBL2 - VC Resource 0 Arbitration Table Entry 2 (0x228) on page 8-51
0x22C	DWord	Px_VCR0TBL3	VCR0TBL3 - VC Resource 0 Arbitration Table Entry 3 (0x22C) on page 8-51
0x280	Dword	Px_PWRBCAP	PWRBCAP - Power Budgeting Capabilities (0x280) on page 8-52
0x284	Dword	Px_PWRBDSEL	PWRBDSEL - Power Budgeting Data Select (0x284) on page 8-52
0x288	Dword	Px_PWRBD	PWRBD - Power Budgeting Data (0x288) on page 8-52
0x28C	Dword	Px_PWRBPBC	PWRBPBC - Power Budgeting Power Budget Capability (0x28C) on page 8-53
0x300	Dword	Px_PWRBDV0	PWRBDV[7:0] - Power Budgeting Data Value [7:0] (0x300 - 0X31C) on page 8-53
0x304	Dword	Px_PWRBDV1	PWRBDV[7:0] - Power Budgeting Data Value [7:0] (0x300 - 0X31C) on page 8-53
0x308	Dword	Px_PWRBDV2	PWRBDV[7:0] - Power Budgeting Data Value [7:0] (0x300 - 0X31C) on page 8-53
0x30C	Dword	Px_PWRBDV3	PWRBDV[7:0] - Power Budgeting Data Value [7:0] (0x300 - 0X31C) on page 8-53
0x310	Dword	Px_PWRBDV4	PWRBDV[7:0] - Power Budgeting Data Value [7:0] (0x300 - 0X31C) on page 8-53
0x314	Dword	Px_PWRBDV5	PWRBDV[7:0] - Power Budgeting Data Value [7:0] (0x300 - 0X31C) on page 8-53
0x318	Dword	Px_PWRBDV6	PWRBDV[7:0] - Power Budgeting Data Value [7:0] (0x300 - 0X31C) on page 8-53
0x31C	Dword	Px_PWRBDV7	PWRBDV[7:0] - Power Budgeting Data Value [7:0] (0x300 - 0X31C) on page 8-53
0x500	Dword	Px_SERDESCTL	SERDESCTL - SerDes Control (0x500) on page 8-60
0x534	Dword	Px_PHYLSTATE0	PHYLSTATE0 - Phy Link State 0 (0x534) on page 8-61
0x708	Dword	Px_PMETOATIMER	PMETOATIMER - PME_TO_Ack Timer (OX708) on page 8-61

Table 8.3 Downstream Ports 2, 4, 6 Configuration Space Registers (Part 4 of 4)

## Notes

## Register Definitions

## Type 1 Configuration Header Registers

## VID - Vendor Identification Register (0x000)

Bit Field	Field Name	Type	Default Value	Description
15:0	VID	RO	0x111D	<b>Vendor Identification.</b> This field contains the 16-bit vendor ID value assigned to IDT. See section Vendor ID on page 1-4.

## DID - Device Identification Register (0x002)

Bit Field	Field Name	Type	Default Value	Description
15:0	DID	RO	-	<b>Device Identification.</b> This field contains the 16-bit device ID assigned by IDT to this bridge. See section Device ID on page 1-4.

## PCICMD - PCI Command Register (0x004)

Bit Field	Field Name	Type	Default Value	Description
0	IOAE	RW	0x0	<b>I/O Access Enable.</b> When this bit is cleared, the bridge does not respond to I/O accesses from the primary bus specified by IOBASE and IOLIMIT. 0x0 - (disable) Disable I/O space. 0x1 - (enable) Enable I/O space.
1	MAE	RW	0x0	<b>Memory Access Enable.</b> When this bit is cleared, the bridge does not respond to memory and prefetchable memory space access from the primary bus specified by MBASE, MLIMIT, PMBASE and PMLIMIT. 0x0 - (disable) Disable memory space. 0x1 - (enable) Enable memory space.
2	BME	RW	0x0	<b>Bus Master Enable.</b> When this bit is cleared, the bridge does not issue requests (e.g., memory, I/O and MSIs since they are in-band writes) on behalf of subordinate devices and handles these as Unsupported Requests (UR). Additionally, the bridge handles non-posted transactions in the upstream direction with a Unsupported Request (UR) completion. This bit does not affect completions in either direction or the forwarding of non memory or I/O requests. 0x0 - (disable) Disable request forwarding. 0x1 - (enable) Enable request forwarding.
3	SSE	RO	0x0	<b>Special Cycle Enable.</b> Not applicable.
4	MWI	RO	0x0	<b>Memory Write Invalidate.</b> Not applicable.
5	VGAS	RO	0x0	<b>VGA Palette Snoop.</b> Not applicable.
6	PERRE	RW	0x0	<b>Parity Error Enable.</b> Not applicable.
7	ADSTEP	RO	0x0	<b>Address Data Stepping.</b> Not applicable.



## Notes

Bit Field	Field Name	Type	Default Value	Description
8	SERRE	RW	0x0	<b>SERR Enable.</b> Non-fatal and fatal errors detected by the bridge are reported to the Root Complex when this bit is set or the bits in the PCI Express Device Control register are set (see PCIEDCTL - PCI Express Device Control (0x048)). In addition, when this bit is set it enables the forwarding of ERR_NONFATAL and ERR_FATAL error messages from the secondary to the primary interface. ERR_COR messages are unaffected by this bit and are always forwarded. 0x0 - (disable) Disable non-fatal and fatal error reporting if also disabled in Device Control register. 0x1 - (enable) Enable non-fatal and fatal error reporting.
9	FB2B	RO	0x0	<b>Fast Back-to-Back Enable.</b> Not applicable.
10	INTXD	RW	0x0	<b>INTx Disable.</b> Controls the ability of the PCI-PCI bridge to generate an INTx interrupt message. When this bit is set, any interrupts generated by this bridge are negated. This may result in a change in the resolved interrupt state of the bridge. This bit has no effect on interrupts forwarded from the secondary to the primary interface.
15:11	Reserved	RO	0x0	Reserved field.

**PCISTS - PCI Status Register (0x006)**

Bit Field	Field Name	Type	Default Value	Description
2:0	Reserved	RO	0x0	Reserved field.
3	INTS	RO	0x0	<b>INTx Status.</b> This bit is set when an INTx interrupt is pending from the device. INTx emulation interrupts forwarded by switch ports from devices downstream of the bridge are not reflected in this bit. For downstream ports, this bit is set if an interrupt has been "asserted" by the corresponding port's hot-plug controller. In the upstream port this field is always zero.
4	CAPL	RO	0x1	<b>Capabilities List.</b> This bit is hardwired to one to indicate that the bridge implements an extended capability list item.
5	C66MHZ	RO	0x0	<b>66 MHz Capable.</b> Not applicable.
6	Reserved	RO	0x0	Reserved field.
7	FB2B	RO	0x0	<b>Fast Back-to-Back (FB2B).</b> Not applicable.
8	MDPED	RO	0x0	<b>Master Data Parity Error Detected.</b> Not applicable.
10:9	DEVT	RO	0x0	<b>DEVSEL# Timing.</b> Not applicable.
11	STAS	RO	0x0	<b>Signalled Target Abort.</b> Not applicable since a target abort is never signalled.
12	RTAS	RO	0x0	<b>Received Target Abort.</b> Not applicable.
13	RMAS	RO	0x0	<b>Received Master Abort.</b> Not applicable.

## Notes

Bit Field	Field Name	Type	Default Value	Description
14	SSE	RW1C	0x0	<b>Signalled System Error.</b> This bit is set when the bridge sends a ERR_FATAL or ERR_NONFATAL message and the SERR Enable (SERRE) bit is set in the PCICMD register. 0x0 - (noerror) no error. 0x1 - (error) This bit is set when a fatal or non-fatal error is signalled.
15	DPE	RW1C	0x0	<b>Detected Parity Error.</b> This bit is set by the bridge whenever it receives a poisoned TLP on the primary side regardless of the state of the PERRE bit in the PCI Command register.

**RID - Revision Identification Register (0x008)**

Bit Field	Field Name	Type	Default Value	Description
7:0	RID	RWL	-	<b>Revision ID.</b> This field contains the revision identification number for the device. See section Revision ID on page 1-4.

**CCODE - Class Code Register (0x009)**

Bit Field	Field Name	Type	Default Value	Description
7:0	INTF	RO	0x00	<b>Interface.</b> This value indicates that the device is a PCI-PCI bridge that does not support subtractive decode.
15:8	SUB	RO	0x04	<b>Sub Class Code.</b> This value indicates that the device is a PCI-PCI bridge.
23:16	BASE	RO	0x06	<b>Base Class Code.</b> This value indicates that the device is a bridge.

**CLS - Cache Line Size Register (0x00C)**

Bit Field	Field Name	Type	Default Value	Description
7:0	CLS	RW	0x00	<b>Cache Line Size.</b> This field has no effect on the bridge's functionality but may be read and written by software. This field is implemented for compatibility with legacy software.

**PLTIMER - Primary Latency Timer (0x00D)**

Bit Field	Field Name	Type	Default Value	Description
7:0	PLTIMER	RO	0x00	<b>Primary Latency Timer.</b> Not applicable.

## Notes

**HDR - Header Type Register (0x00E)**

Bit Field	Field Name	Type	Default Value	Description
7:0	HDR	RO	0x01	<b>Header Type.</b> This value indicates a type 1 header with a single function bridge layout.

**BIST - Built-in Self Test Register (0x00F)**

Bit Field	Field Name	Type	Default Value	Description
7:0	BIST	RO	0x0	<b>BIST.</b> This value indicates that the bridge does not implement BIST.

**BAR0 - Base Address Register 0 (0x010)**

Bit Field	Field Name	Type	Default Value	Description
31:0	BAR	RO	0x0	<b>Base Address Register.</b> Not applicable.

**BAR1 - Base Address Register 1 (0x014)**

Bit Field	Field Name	Type	Default Value	Description
31:0	BAR	RO	0x0	<b>Base Address Register.</b> Not applicable.

**PBUSN - Primary Bus Number Register (0x018)**

Bit Field	Field Name	Type	Default Value	Description
7:0	PBUSN	RW	0x0	<b>Primary Bus Number.</b> This field is used to record the bus number of the PCI bus segment to which the primary interface of the bridge is connected. This field has no functional effect within the PES16T4G2 but is implemented as a read/write register for software compatibility

**SBUSN - Secondary Bus Number Register (0x019)**

Bit Field	Field Name	Type	Default Value	Description
7:0	SBUSN	RW	0x0	<b>Secondary Bus Number.</b> This field is used to record the bus number of the PCI bus segment to which the secondary interface of the bridge is connected.

## Notes

**SUBUSN - Subordinate Bus Number Register (0x01A)**

Bit Field	Field Name	Type	Default Value	Description
7:0	SUBUSN	RW	0x0	<b>Subordinate Bus Number.</b> The Subordinate Bus Number register is used to record the bus number of the highest numbered PCI bus segment which is behind (or subordinate to) the bridge.

**SLTIMER - Secondary Latency Timer Register (0x01B)**

Bit Field	Field Name	Type	Default Value	Description
7:0	SLTIMER	RO	0x0	<b>Secondary Latency Timer.</b> Not applicable.

**IOBASE - I/O Base Register (0x01C)**

Bit Field	Field Name	Type	Default Value	Description
0	IOCAP	RWL	0x1	<b>I/O Capability.</b> Indicates if the bridge supports 16-bit or 32-bit I/O addressing. 0x0 - (io16) 16-bit I/O addressing. 0x1 - (io32) 32-bit I/O addressing.
3:1	Reserved	RO	0x0	Reserved field.
7:4	IOBASE	RW	0xF	<b>I/O Base.</b> The IOBASE and IOLIMIT registers are used to control the forwarding of I/O transactions between the primary and secondary interfaces of the bridge. This field contains A[15:12] of the lowest I/O address aligned on a 4KB boundary that is below the primary interface of the bridge.

**IOLIMIT - I/O Limit Register (0x01D)**

Bit Field	Field Name	Type	Default Value	Description
0	IOCAP	RO	0x1	<b>I/O Capability.</b> Indicates if the bridge supports 16-bit or 32-bit I/O addressing. This bit always reflects the value of the IOCAP field in the IOBASE register.
3:1	Reserved	RO	0x0	Reserved field.
7:4	IOLIMIT	RW	0x0	<b>I/O Limit.</b> The IOBASE and IOLIMIT registers are used to control the forwarding of I/O transactions between the primary and secondary interfaces of the bridge. This field contains A[15:12] of the highest I/O address, with A[11:0] assumed to be 0xFFF, that is below the primary interface of the bridge.

## Notes

**SECSTS - Secondary Status Register (0x01E)**

Bit Field	Field Name	Type	Default Value	Description
7:0	Reserved	RO	0x0	Reserved field.
8	MDPED	RO	0x0	<b>Master Data Parity Error.</b> Not applicable.
10:9	DVSEL	RO	0x0	Not applicable.
11	STAS	RO	0x0	<b>Signalled Target Abort Status.</b> Not applicable.
12	RTAS	RO	0x0	<b>Received Target Abort Status.</b> Not applicable.
13	RMAS	RO	0x0	<b>Received Master Abort Status.</b> Not applicable.
14	RSE	RW1C	0x0	<b>Received System Error.</b> This bit is controlled by the SERR enable bit in the Bridge Control (BCTL) register. If the SERRE bit is cleared in BCTL, then this bit is never set. Otherwise, this bit is set if the secondary side of the bridge receives an ERR_FATAL or ERR_NONFATAL message.
15	DPE	RW1C	0x0	<b>Detected Parity Error.</b> This bit is set by the bridge whenever it receives a poisoned TLP on the secondary side regardless of the state of the PERRE bit in the PCI Command register

**MBASE - Memory Base Register (0x020)**

Bit Field	Field Name	Type	Default Value	Description
3:0	Reserved	RO	0x0	Reserved field.
15:4	MBASE	RW	0xFFFF	<b>Memory Address Base.</b> The MBASE and MLIMIT registers are used to control the forwarding of non-prefetchable transactions between the primary and secondary interfaces of the bridge. This field contains A[31:20] of the lowest address aligned on a 1MB boundary that is below the primary interface of the bridge.

**MLIMIT - Memory Limit Register (0x022)**

Bit Field	Field Name	Type	Default Value	Description
3:0	Reserved	RO	0x0	Reserved field.
15:4	MLIMIT	RW	0x0	<b>Memory Address Limit.</b> The MBASE and MLIMIT registers are used to control the forwarding of non-prefetchable transactions between the primary and secondary interfaces of the bridge. This field contains A[31:20] of the highest address, with A[19:0] assumed to be 0xF_FFFF, that is below the primary interface of the bridge.

## Notes

**PMBASE - Prefetchable Memory Base Register (0x024)**

Bit Field	Field Name	Type	Default Value	Description
0	PMCAP	RWL	0x1	<b>Prefetchable Memory Capability.</b> Indicates if the bridge supports 32-bit or 64-bit prefetchable memory addressing. 0x0 - (prefmem32) 32-bit prefetchable memory addressing. 0x1 - (prefmem64) 64-bit prefetchable memory addressing.
3:1	Reserved	RO	0x0	Reserved field.
15:4	PMBASE	RW	0xFFF	<b>Prefetchable Memory Address Base.</b> The PMBASE, PMBASEU, PMLIMIT and PMLIMITU registers are used to control the forwarding of prefetchable transactions between the primary and secondary interfaces of the bridge. This field contains A[31:20] of the lowest memory address aligned on a 1MB boundary that is below the primary interface of the bridge. PMBASEU specifies the remaining bits.

**PMLIMIT - Prefetchable Memory Limit Register (0x026)**

Bit Field	Field Name	Type	Default Value	Description
0	PMCAP	RO	0x1	<b>Prefetchable Memory Capability.</b> Indicates if the bridge supports 32-bit or 64-bit prefetchable memory addressing. This bit always reflects the value in the PMCAP field in the PMBASE register.
3:1	Reserved	RO	0x0	Reserved field.
15:4	PMLIMIT	RW	0x0	<b>Prefetchable Memory Address Limit.</b> The PMBASE, PMBASEU, PMLIMIT and PMLIMITU registers are used to control the forwarding of prefetchable transactions between the primary and secondary interfaces of the bridge. This field contains A[31:20] of the highest memory address, with A[19:0] assumed to be 0xF_FFFF, that is below the primary interface of the bridge. PMLIMITU specifies the remaining bits

**PMBASEU - Prefetchable Memory Base Upper Register (0x028)**

Bit Field	Field Name	Type	Default Value	Description
31:0	PMBASEU	RW	0xFFFF_FF FF	<b>Prefetchable Memory Address Base Upper.</b> This field specifies the upper 32-bits of PMBASE when 64-bit addressing is used. When the PMCAP field in the PMBASE register is cleared, this field becomes read-only with a value of zero.

## Notes

**PMLIMITU - Prefetchable Memory Limit Upper Register (0x02C)**

Bit Field	Field Name	Type	Default Value	Description
31:0	PMLIMITU	RW	0x0	<b>Prefetchable Memory Address Limit Upper.</b> This field specifies the upper 32-bits of PMLIMIT. When the PMCAP field in the PMBASE register is cleared, this field becomes read-only with a value of zero.

**IOBASEU - I/O Base Upper Register (0x030)**

Bit Field	Field Name	Type	Default Value	Description
15:0	IOBASEU	RW	0xFFFF	<b>I/O Address Base Upper.</b> This field specifies the upper 16-bits of IOBASE. When the IOCAP field in the IOBASE register is cleared, this field becomes read-only with a value of zero.

**IOLIMITU - I/O Limit Upper Register (0x032)**

Bit Field	Field Name	Type	Default Value	Description
15:0	IOLIMITU	RW	0x0	<b>Prefetchable IO Limit Upper.</b> This field specifies the upper 16-bits of IOLIMIT. When the IOCAP field in the IOBASE register is cleared, this field becomes read-only with a value of zero.

**CAPPTR - Capabilities Pointer Register (0x034)**

Bit Field	Field Name	Type	Default Value	Description
7:0	CAPPTR	RWL	0x40	<b>Capabilities Pointer.</b> This field specifies a pointer to the head of the capabilities structure.

**EROMBASE - Expansion ROM Base Address Register (0x038)**

Bit Field	Field Name	Type	Default Value	Description
31:0	EROMBASE	RO	0x0	<b>Expansion ROM Base Address.</b> The bridge does not implement an expansion ROM. Thus, this field is hardwired to zero.

## Notes

**INTRLINE - Interrupt Line Register (0x03C)**

Bit Field	Field Name	Type	Default Value	Description
7:0	INTRLINE	RW	0x0	<b>Interrupt Line.</b> This register communicates interrupt line routing information. Values in this register are programmed by system software and are system architecture specific. The bridge does not use the value in this register. Legacy interrupts may be implemented by downstream ports.

**INTRPIN - Interrupt PIN Register (0x03D)**

Bit Field	Field Name	Type	Default Value	Description
7:0	INTRPIN	RWL	0x0	<b>Interrupt Pin.</b> Interrupt pin or legacy interrupt messages are not used by the bridge by default. However, they can be used for hot-plug by the downstream ports. This field should only be configured with values of 0x0 through 0x4. 0x0 - (none) Bridge does not generate any interrupts. 0x1 - (INTA) Bridge generates INTA interrupts. 0x2 - (INTB) Bridge generates INTB interrupts. 0x3 - (INTC) Bridge generates INTC interrupts. 0x4 - (INTD) Bridge generates INTD interrupts.

**BCTL - Bridge Control Register (0x03E)**

Bit Field	Field Name	Type	Default Value	Description
0	PERRE	RW	0x0	<b>Parity Error Response Enable.</b> Not applicable.
1	SERRE	RW	0x0	<b>System Error Enable.</b> This bit controls forwarding of ERR_COR, ERR_NONFATAL, ERR_FATAL from the secondary interface of the bridge to the primary interface. Note that error reporting must be enabled in the Command register or PCI Express Capability structure, Device Control register for errors to be reported on the primary interface. 0x0 - (ignore) Do not forward errors from the secondary to the primary interface. 0x1 - (report) Enable forwarding of errors from secondary to the primary interface.
2	ISAEN	RW	0x0	<b>ISA Enable.</b> This bit controls the routing of ISA I/O transactions. 0 - (disable) Forward downstream all I/O addresses in the address range defined by the I/O base and I/O limit registers 1 - (enable) Forward upstream ISA I/O addresses in the address range defined by the I/O base and I/O limit registers that are in the first 64 KB of PCI I/O address space (top 768 bytes of each 1-KB block)



## Notes

Bit Field	Field Name	Type	Default Value	Description
3	VGAEN	RW	0x0	<b>VGA Enable.</b> Controls the routing of processor-initiated transactions targeting VGA. 0 - (block) Do not forward VGA compatible addresses from the primary interface to the secondary interface 1 - (forward) Forward VGA compatible addresses from the primary to the secondary interface.
4	VGA16EN	RW	0x0	<b>VGA 16-bit Enable.</b> This bit only has an effect when the VGAEN bit is set in this register. This read/write bit enables system configuration software to select between 10-bit and 16-bit I/O space decoding for VGA transactions. 0 - (bit10) Perform 10-bit decoding. I/O space aliasing occurs in this mode. 1 - (bit16) Perform 16-bit decoding. No I/O space aliasing occurs in this mode.
5	Reserved	RO	0x0	Reserved field.
6	SRESET	RW	0x0	<b>Secondary Bus Reset.</b> Setting this bit triggers a secondary bus reset. In the upstream port, setting this bit initiates a Upstream Secondary Bus Reset. In a downstream port, setting this bit initiates a Downstream Secondary Bus Reset. Port Configuration Registers must not be changed except as required to update port status.
15:7	Reserved	RO	0x0	Reserved field.

## PCI Express Capability Structure

## PCIECAP - PCI Express Capability (0x040)

Bit Field	Field Name	Type	Default Value	Description
7:0	CAPID	RO	0x10	<b>Capability ID.</b> The value of 0x10 identifies this capability as a PCI Express capability structure.
15:8	NXTPTR	RWL	0xC0	<b>Next Pointer.</b> This field contains a pointer to the next capability structure.
19:16	VER	RWL	0x2	<b>PCI Express Capability Version.</b> This field indicates the PCI-SIG defined PCI Express capability structure version number. The PES16T4G2 is compliant with the Express Capabilities Register Expansion ECN.
23:20	TYPE	RO	Upstream: 0x5 Downstream: 0x6	<b>Port Type.</b> This field identifies the type of switch port (upstream or downstream).

## Notes

Bit Field	Field Name	Type	Default Value	Description
24	SLOT	RWL	0x0	<b>Slot Implemented.</b> This bit is set when the PCI Express link associated with this Port is connected to a slot. This field does not apply to an upstream port and should be set to zero.
29:25	IMN	RO	0x0	<b>Interrupt Message Number.</b> The function is allocated none (upstream ports) or only one (downstream ports) MSI. Therefore, this field is set to zero.
31:30	Reserved	RO	0x0	Reserved field.

## PCIEDCAP - PCI Express Device Capabilities (0x044)

Bit Field	Field Name	Type	Default Value	Description
2:0	MPAYLOAD	RWL	HWINIT	<b>Maximum Payload Size Supported.</b> This field indicates the maximum payload size that the device can support for TLPs. For all bond options the default value is 0x4 which corresponds to 2048 bytes.
4:3	PFS	RO	0x0	<b>Phantom Functions Supported.</b> This field indicates the support for unclaimed function number to extend the number of outstanding transactions allowed by logically combining unclaimed function numbers. The value is hardwired to 0x0 to indicate that no function number bits are used for phantom functions.
5	ETAG	RWL	0x1	<b>Extended Tag Field Support.</b> This field indicates the maximum supported size of the Tag field as a requester.
8:6	E0AL	RO	0x0	<b>Endpoint L0s Acceptable Latency.</b> This field indicates the acceptable total latency that an endpoint can withstand due to transition from the L0s state to the L0 state. The value is hardwired to 0x0 as this field does not apply to a switch.
11:9	E1AL	RO	0x0	<b>Endpoint L1 Acceptable Latency.</b> This field indicates the acceptable total latency that an endpoint can withstand due to transition from the L1 state to the L0 state. The value is hardwired to 0x0 as this field does not apply to a switch.
12	ABP	RO	0x0	<b>Attention Button Present.</b> In PCIe base 1.0a when set, this bit indicates that an Attention Button is implemented on the card/module. The value of this field is undefined in PCIe base 1.1
13	AIP	RO	0x0	<b>Attention Indicator Present.</b> In PCIe base 1.0a when set, this bit indicates that an Attention Indicator is implemented on the card/module. The value of this field is undefined in PCIe base 1.1
14	PIP	RO	0x0	<b>Power Indicator Present.</b> In PCIe base 1.0a when set, this bit indicates that a Power Indicator is implemented on the card/module. The value of this field is undefined in PCIe base 1.1
15	RBERR	RO	0x1	<b>Role Based Error Reporting.</b> This bit is set to indicate that the PES16T4G2 supports error reporting as defined in the PCIe base 1.1 specification.
17:16	Reserved	RO	0x0	Reserved field.

## Notes

Bit Field	Field Name	Type	Default Value	Description
25:18	CSPLV	RO	0x0	<b>Captured Slot Power Limit Value.</b> This field in combination with the Slot Power Limit Scale value, specifies the upper limit on power supplied by the slot. Power limit (in Watts) calculated by multiplying the value in this field by the value in the Slot Power Limit Scale field. The value of this field is set by a Set_Slot_Power_Limit Message and is only applicable for the upstream port. This field is always zero in downstream ports.
27:26	CSPLS	RO	0x0	<b>Captured Slot Power Limit Scale.</b> This field specifies the scale used for the Slot Power Limit Value. The value of this field is set by a Set_Slot_Power_Limit Message and is only applicable for the upstream port. This field is always zero in downstream ports. 0 - (v1) 1.0x 1 - (v1p1) 0.1x 2 - (v0p01) 0.01x 3 - (v0p001x) 0.001x
31:28	Reserved	RO	0x0	Reserved field.

**PCIEDCTL - PCI Express Device Control (0x048)**

Bit Field	Field Name	Type	Default Value	Description
0	CEREN	RW	0x0	<b>Correctable Error Reporting Enable.</b> This bit controls reporting of correctable errors.
1	NFEREN	RW	0x0	<b>Non-Fatal Error Reporting Enable.</b> This bit controls reporting of non-fatal errors.
2	FEREN	RW	0x0	<b>Fatal Error Reporting Enable.</b> This bit controls reporting of fatal errors.
3	URREN	RW	0x0	<b>Unsupported Request Reporting Enable.</b> This bit controls reporting of unsupported requests.
4	ERO	RO	0x0	<b>Enable Relaxed Ordering.</b> When set, this bit enables relaxed ordering. This bit is not applicable to the switch, since the switch never sets the relaxed ordering bit in transactions it initiates as a requester. Therefore, this bit is hardwired to 0x0.
7:5	MPS	RW	0x0	<b>Max Payload Size.</b> This field sets maximum TLP payload size for the device. 0x0 - (s128) 128 bytes max payload size 0x1 - (s256) 256 bytes max payload size 0x2 - (s512) 512 bytes max payload size 0x3 - (s1024) 1024 bytes max payload size 0x4 - (s2048) 2048 bytes max payload size 0x5 - reserved (treated as 128 bytes) 0x6 - reserved (treated as 128 bytes) 0x7 - reserved (treated as 128 bytes)

## Notes

Bit Field	Field Name	Type	Default Value	Description
8	ETFEN	RW	0x0	<b>Extended Tag Field Enable.</b> Since the bridge never generates a transaction that requires a completion, this bit has no functional effect on the device during normal operation. To aid in debug, when the SEQTAG field is set in the TLCTL register, this field controls whether tags are generated in the range from 0 through 31 or from 0 through 255.
9	PFEN	RO	0x0	<b>Phantom Function Enable.</b> The bridge does not support phantom function numbers. Therefore, this field is hardwired to zero.
10	AUXPMEN	RO	0x0	<b>Auxiliary Power PM Enable.</b> The device does not implement this capability.
11	ENS	RO	0x0	<b>Enable No Snoop.</b> The bridge does not generate transactions with the No Snoop bit set and passes transactions through the bridge with the No Snoop bit unmodified.
14:12	MRRS	RO	0x0	<b>Maximum Read Request Size.</b> The bridge does not generate transactions larger than 128 bytes and passes transactions through the bridge with the size unmodified. Therefore, this field has no functional effect on the behavior of the bridge.
15	Reserved	RO	0x0	Reserved field.

**PCIEDSTS - PCI Express Device Status (0x04A)**

Bit Field	Field Name	Type	Default Value	Description
0	CED	RW1C	0x0	<b>Correctable Error Detected.</b> This bit indicates the status of correctable errors. Errors are logged in this register regardless of whether error reporting is enabled or not.
1	NFED	RW1C	0x0	<b>Non-Fatal Error Detected.</b> This bit indicates the status of correctable errors. Errors are logged in this register regardless of whether error reporting is enabled or not.
2	FED	RW1C	0x0	<b>Fatal Error Detected.</b> This bit indicates the status of Fatal errors. Errors are logged in this registers regardless of whether error reporting is enabled or not.
3	URD	RW1C	0x0	<b>Unsupported Request Detected.</b> This bit indicates the device received an Unsupported Request. Errors are logged in this register regardless of whether error reporting is enabled or not.
4	AUXPD	RO	0x0	<b>Aux Power Detected.</b> Devices that require AUX power, set this bit when AUX power is detected. This device does not require AUX power, hence the value is hardwired to zero.
5	TP	RO	0x0	<b>Transactions Pending.</b> The bridge does not issue Non-Posted Requests on its own behalf. Therefore, this field is hardwired to zero.
15:6	Reserved	RO	0x0	Reserved field.

## Notes

## PCIELCAP - PCI Express Link Capabilities (0x04C)

Bit Field	Field Name	Type	Default Value	Description
3:0	MAXLNKSPD	RO	0x2	<b>Maximum Link Speed.</b> This field indicates the supported link speeds of the port. 1 - (gen1) 2.5 Gbps 2 - (gen2) 5 Gbps others-reserved The initial value of this field is always 0x2 for the upstream and downstream ports.
9:4	MAXLNKWDTH	RWL	HWINIT	<b>Maximum Link Width.</b> This field indicates the maximum link width of the given PCI Express link. This field may be overridden to allow the link width to be forced to a smaller value. Setting this field to an invalid or reserved value is allowed, and results in the port operating at its default (i.e., initial) value. The value written to this field is never modified by hardware. See section Port Configuration on page 1-10 for more information. 0 - reserved 1 - (x1) x1 link width 2 - (x2) x2 link width 4 - (x4) x4 link width others-reserved
11:10	ASPMS	RO	0x3	<b>Active State Power Management (ASPM) Support.</b> This field is hardwired to 0x3 to indicate L0s and L1 Support.
14:12	LOSEL	RWL	HWINIT	<b>L0s Exit Latency.</b> This field indicates the L0s exit latency for the given PCI Express link. The default value of 0x5 corresponds to a L0s exit latency of 1 $\mu$ s to 2 $\mu$ s.
17:15	L1EL	RWL	0x2	<b>L1 Exit Latency.</b> This field indicates the L1 exit latency for the given PCI Express link. Transitioning from L1 to L0 always requires 2.3 $\mu$ S. Therefore, a value 2 $\mu$ s to less than 4 $\mu$ s is reported with a default value of 0x2.
18	CPM	RWL	0x0	<b>Clock Power Management.</b> This bit indicates if the component tolerates removal of the reference clock via the "CLKREQ#" mechanism. The PES16T4G2 does not support the removal of reference clocks.
19	SDERR	RWL	Upstream: 0x0 Downstream: 0x1	<b>Surprise Down Error Reporting.</b> The PES16T4G2 downstream ports support surprise down error reporting. This field does not apply to an upstream port and should be hardwired to zero.
20	DLLLA	RWL	Upstream: 0x0 Downstream: 0x1	<b>Data Link Layer Link Active Reporting.</b> The PES16T4G2 downstream ports support the capability of reporting the DL_Active state of the data link control and management state machine. Modification of this bit changes the advertised capability value but does not modify the device behavior (i.e., status is always reported regardless of this field value). This field is not applicable for the upstream port and must be hardwired to zero.

## Notes

Bit Field	Field Name	Type	Default Value	Description
21	LBN	RWL	Upstream: 0x0 Down- stream: 0x1	<b>Link Bandwidth Notification Capability.</b> When set, this bit indicates support for the link bandwidth notification status and interrupt mechanisms. The PES16T4G2 downstream ports support the capability. This field is not applicable for the upstream port and must be zero.
23:22	Reserved	RO	0x0	Reserved field.
31:24	PORTNUM	RO	Port 0: 0x0 Port 2: 0x2 Port 4: 0x4 Port 6: 0x6	<b>Port Number.</b> This field indicates the PCI express port number for the corresponding link.

**PCIELCTL - PCI Express Link Control (0x050)**

Bit Field	Field Name	Type	Default Value	Description
1:0	ASPM	RW	0x0	<b>Active State Power Management (ASPM) Control.</b> This field controls the level of ASPM supported by the link. The initial value corresponds to disabled. The value contained in Serial EEPROM may override this default value 0x0 - (disabled) disabled 0x1 - (I0s) L0s enable entry 0x2 - (I1) L1 enable entry 0x3 - (I0sI1) L0s and L1 enable entry Note that "L0s enable entry" corresponds to the transmitter entering L0s (the receiver supports this function and is not affected by this setting).
2	Reserved	RO	0x0	Reserved field.
3	RCB	RO	0x0	<b>Read Completion Boundary.</b> This field is not applicable and is hardwired to zero.
4	LDIS	RW	0x0	<b>Link Disable.</b> When set in a downstream port, this bit disables the link. This field is not applicable for the upstream port and must be zero.

## Notes

Bit Field	Field Name	Type	Default Value	Description
5	LRET	RW	0x0	<p><b>Link Retrain.</b> Writing a one to this field initiates Link retraining by directing the Physical Layer LTSSM to the Recovery state. This field always returns zero when read.</p> <p>It is permitted to set this bit while simultaneously modifying other fields in this register.</p> <p>When this bit is set and the LTSSM is already in the Recovery or Configuration states, all modifications that affect link retraining are applied in the subsequent retraining. Else, if the LTSSM is not in the Recovery or Configuration states, modifications that affect link retraining are applied immediately.</p> <p>For compliance with the PCIe specification, this bit has no effect on the upstream port when the REGUNLOCK bit is cleared in the SWCTL register. In this mode the field is hardwired to zero. When the REGUNLOCK bit is set, writing a one to the LRET bit initiates link retraining on the upstream port with a delayed effect of 1 ms. The PES16T4G2 always returns a completion to the requester before the effect of this bit is applied.</p>
6	CCLK	RW	0x0	<p><b>Common Clock Configuration.</b> When set, this bit indicates that this component and the component at the opposite end of the link are operating with a distributed common reference clock.</p>
7	ESYNC	RW	0x0	<p><b>Extended Sync.</b> When set this bit forces transmission of additional ordered sets when exiting the L0s state and when in the recovery state.</p>
8	CLKPWRMGT	RO	0x0	<p><b>Enable Clock Power Management.</b> The PES16T4G2 does not support this feature.</p>
9	HAWD	RO	0x0	<p><b>Hardware Autonomous Width Disable.</b> When set, this bit disables hardware from changing the link width for reasons other than attempting to correct for unreliable link operation by reducing the link width.</p> <p>The PES16T4G2 ports do not have a hardware autonomous mechanism to change link width, except due to link reliability issues. Therefore, this bit is not applicable to the PES16T4G2 ports.</p> <p>Note that this bit does not affect link width changes triggered by the link width re-configuration mechanism.</p>
10	LBWINTEN	RW	0x0	<p><b>Link Bandwidth Management Interrupt Enable.</b> When set, this bit enables the generation of an interrupt to indicate that the LBWSTS bit has been set in the PCIELSTS register.</p> <p>If the LBN field in the PCIELCAP register is cleared, this field is hardwired to zero.</p> <p>This field is hardwired to zero in the upstream port.</p>
11	LABWINTEN	RW	0x0	<p><b>Link Autonomous Bandwidth Interrupt Enable.</b> When set, this bit enables the generation of an interrupt to indicate that the LABWSTS bit has been set in the PCIELSTS register.</p> <p>If the LBN field in the PCIELCAP register is cleared, this field is hardwired to zero.</p> <p>This field is hardwired to zero in the upstream port.</p>
15:12	Reserved	RO	0x0	Reserved field.

## Notes

## PCIELSTS - PCI Express Link Status (0x052)

Bit Field	Field Name	Type	Default Value	Description
3:0	CLS	RO	0x1	<b>Current Link Speed.</b> This field indicates the current link speed of the port. 1 - (gen1) 2.5 Gbps 2 - (gen2) 5 Gbps others-reserved
9:4	NLW	RO	HWINIT	<b>Negotiated Link Width.</b> This field indicates the negotiated width of the link. Defined encodings are: 00 0001b - x1 00 0010b - x2 00 0100b - x4 00 1000b - x8 00 1100b - x12 01 0000b - x16 10 0000b - x32 When the MAXLNKWDTH field in the PCIELCAP register selects a width not supported by the port, the value of this field corresponds to the setting of the MAXLNKWDTH field, regardless of the actual negotiated link width. When the MAXLNKWDTH field in the PCIELCAP register selects a width supported by the port, but the link is unable to train, the value in this field is set to 0x0.
10	TERR	RO	0x0	<b>Training Error.</b> In PCIe base 1.0a when set, this bit indicates that a link training error has occurred. The value of this field is undefined in the PCIe base 2.0 specification.
11	LTRAIN	RO	0x0	<b>Link Training.</b> When set, this bit indicates that link training is in progress. Specifically, this bit is set when the Physical Layer LTSSM is in the Configuration or Recovery state, or when a 0x1 was written to the LRET bit in the PCIELCTL register, but Link training has not yet begun. Note that in the upstream port, LRET has a delayed effect of 1 ms. Hardware clears this bit when the LTSSM exits the Configuration/ Recovery state
12	SCLK	RWL	HWINIT	<b>Slot Clock Configuration.</b> When set, this bit indicates that the component uses the same physical reference clock that the platform provides. The initial value of this field is the state of the CCLKUS signal for the upstream port and the CCLKDS signal for downstream ports. The serial EEPROM may override these default values.
13	DLLLA	RO	0x0	<b>Data Link Layer Link Active.</b> This bit indicates the status for the data link control and management state machine. 0x0 - (not_active) Data link layer not active state 0x1 - (active) Data link layer active state This bit must never be set by hardware if the DLLLA bit in the PCIELCAP register is cleared.



## Notes

Bit Field	Field Name	Type	Default Value	Description
14	LBWSTS	RW1C	0x0	<p><b>Link Bandwidth Management Status.</b> This bit is set to indicate that either of the following have occurred without the link transitioning through the DL_Down state.</p> <p>A link retraining initiated by setting the LRET bit in the PCIELCTL register has completed.</p> <p>The PHY has autonomously changed link speed or width to attempt to correct unreliable link operation either through an LTSSM time-out or a higher level process.</p> <p>This bit must be set if the Physical Layer reports a speed or width change was initiated by the downstream component that was not indicated as an autonomous change.</p> <p>If the LBN field in the PCIELCAP register is cleared, this field is hardwired to zero.</p> <p>This field is hardwired to zero in the upstream port.</p>
15	LABWSTS	RW1C	0x0	<p><b>Link Autonomous Bandwidth Status.</b> This bit is set to indicate that either that the PHY has autonomously changed link speed or width for reasons other than to attempt to correct unreliable link operation.</p> <p>This bit must be set if the Physical Layer reports a speed or width change was initiated by the downstream component that was indicated as an autonomous change.</p> <p>If the LBN field in the PCIELCAP register is cleared, this field is hardwired to zero.</p> <p>This field is hardwired to zero in the upstream port.</p>

**PCIESCAP - PCI Express Slot Capabilities (0x054)**

Bit Field	Field Name	Type	Default Value	Description
0	ABP	RWL	0x0	<p><b>Attention Button Present.</b> This bit is set when the Attention Button is implemented for the port.</p> <p>This bit is read-only and has a value of zero when the SLOT bit in the PCIECAP register is cleared.</p>
1	PCP	RWL	0x0	<p><b>Power Control Present.</b> This bit is set when a Power Controller is implemented for the port.</p> <p>This bit is read-only and has a value of zero when the SLOT bit in the PCIECAP register is cleared.</p>
2	MRLP	RWL	0x0	<p><b>MRL Sensor Present.</b> This bit is set when an MRL Sensor is implemented for the port.</p> <p>This bit is read-only and has a value of zero when the SLOT bit in the PCIECAP register is cleared.</p>
3	ATTIP	RWL	0x0	<p><b>Attention Indicator Present.</b> This bit is set when an Attention Indicator is implemented for the port.</p> <p>This bit is read-only and has a value of zero when the SLOT bit in the PCIECAP register is cleared.</p>
4	PWRIP	RWL	0x0	<p><b>Power Indicator Present.</b> This bit is set when an Power Indicator is implemented for the port.</p> <p>This bit is read-only and has a value of zero when the SLOT bit in the PCIECAP register is cleared.</p>

## Notes

Bit Field	Field Name	Type	Default Value	Description
5	HPS	RWL	0x0	<b>Hot Plug Surprise.</b> When set, this bit indicates that a device present in the slot may be removed from the system without notice. This bit is read-only and has a value of zero when the SLOT bit in the PCIECAP register is cleared.
6	HPC	RWL	0x0	<b>Hot Plug Capable.</b> This bit is set if the slot corresponding to the port is capable of supporting hot-plug operations. This bit is read-only and has a value of zero when the SLOT bit in the PCIECAP register is cleared.
14:7	SPLV	RW	0x0	<b>Slot Power Limit Value.</b> In combination with the Slot Power Limit Scale, this field specifies the upper limit on power supplied by the slot. A Set_Slot_Power_Limit message is generated using this field whenever this register is written or when the link transitions from a non DL_Up status to a DL_Up status. This bit is read-only and has a value of zero when the SLOT bit in the PCIECAP register is cleared.
16:15	SPLS	RW	0x0	<b>Slot Power Limit Scale.</b> This field specifies the scale used for the Slot Power Limit Value (SPLV). 0x0 - (x1) 1.0x 0x1 - (xp1) 0.1x 0x2 - (xp01) 0.01x 0x3 - (xp001) 0.001x A Set_Slot_Power_Limit message is generated using this field whenever this register is written or when the link transitions from a non DL_Up status to a DL_Up status. This bit is read-only and has a value of zero when the SLOT bit in the PCIECAP register is cleared.
17	EIP	RWL	0x0	<b>Electromechanical Interlock Present.</b> This bit is set if an electromechanical interlock is implemented on the chassis for this slot. This bit is read-only and has a value of zero when the SLOT bit in the PCIECAP register is cleared.
18	NCCS	RO	0x0	<b>No Command Completed Support.</b> Software notification is always generated when an issued command is completed by the hot-plug controller. Therefore, this field is hardwired to zero.
31:19	PSLOTNUM	RWL	0x0	<b>Physical Slot Number.</b> This field indicates the physical slot number attached to this port. For devices interconnected on the system board, this field should be initialized to zero. This bit is read-only and has a value of zero when the SLOT bit in the PCIECAP register is cleared.

## Notes

## PCIESCTL - PCI Express Slot Control (0x058)

Bit Field	Field Name	Type	Default Value	Description
0	ABPE	RW	0x0	<b>Attention Button Pressed Enable.</b> This bit when set enables generation of a Hot-Plug interrupt or wake-up event on an attention button pressed event. This bit is read-only and has a value of zero when the corresponding capability is not enabled in the PCIESCAP register.
1	PFDE	RW	0x0	<b>Power Fault Detected Enable.</b> This bit when set enables the generation of a Hot-Plug interrupt or wake-up event on a power fault event. This bit is read-only and has a value of zero when the corresponding capability is not enabled in the PCIESCAP register.
2	MRLSCE	RW	0x0	<b>MRL Sensor Change Enable.</b> This bit when set enables the generation of a Hot-Plug interrupt or wake-up event on a MRL sensor change event. This bit is read-only and has a value of zero when the corresponding capability is not enabled in the PCIESCAP register.
3	PDCE	RW	0x0	<b>Presence Detected Changed Enable.</b> This bit when set enables the generation of a Hot-Plug interrupt or wake-up event on a presence detect change event. This bit is read-only and has a value of zero when the corresponding capability is not enabled in the PCIESCAP register.
4	CCIE	RW	0x0	<b>Command Complete Interrupt Enable.</b> This bit when set enables the generation of a Hot-Plug interrupt when a command is completed by the Hot-Plug Controller. This bit is read-only and has a value of zero when the corresponding capability is not enabled in the PCIESCAP register.
5	HPIE	RW	0x0	<b>Hot Plug Interrupt Enable.</b> This bit when set enables generation of a Hot-Plug interrupt on enabled Hot-Plug events. This bit is read-only and has a value of zero when the corresponding capability is not enabled in the PCIESCAP register.
7:6	AIC	RW	0x3	<b>Attention Indicator Control.</b> When read, this register returns the current state of the Attention Indicator. Writing to this register sets the indicator. This bit is read-only and has a value of zero when the corresponding capability is not enabled in the PCIESCAP register. This field is always zero if the ATTIP bit is cleared in the PCIESCAP register. 0x0 - (reserved) Reserved 0x1 - (on) On 0x2 - (blink) Blink 0x3 - (off) Off

## Notes

Bit Field	Field Name	Type	Default Value	Description
9:8	PIC	RW	0x1	<p><b>Power Indicator Control.</b> When read, this register returns the current state of the Power Indicator. Writing to this register sets the indicator.</p> <p>This bit is read-only and has a value of zero when the corresponding capability is not enabled in the PCIESCAP register.</p> <p>This field is always zero if the PWRIP bit is cleared in the PCIESCAP register.</p> <p>0x0 - (reserved) Reserved            0x1 - (on) On            0x2 - (blink) Blink            0x3 - (off) Off</p> <p>This field has no effect on the upstream port.</p>
10	PCC	RW	0x0	<p><b>Power Controller Control.</b> When read, this register returns the current state of the power applied to the slot. Writing to this register sets the power state of the slot.</p> <p>This bit is read-only and has a value of zero when the corresponding capability is not enabled in the PCIESCAP register.</p> <p>0x0 - (on) Power on            0x1 - (off) Power off</p>
11	EIC	RW	0x0	<p><b>Electromechanical Interlock Control.</b> This field always returns a value of zero when read. If an electromechanical interlock is implemented, a write of a one to this field causes the state of the interlock to toggle and a write of a zero has no effect.</p> <p>This bit is read-only and has a value of zero when the corresponding capability is not enabled in the PCIESCAP register.</p>
12	DLLASCE	RW	0x0	<p><b>Data Link Layer Link Active State Change Enable.</b> This bit when set enables generation of a Hot-Plug interrupt or wake-up event on a data link layer active field state change.</p>
15:13	Reserved	RO	0x0	Reserved field.

**PCIESSTS - PCI Express Slot Status (0x05A)**

Bit Field	Field Name	Type	Default Value	Description
0	ABP	RW1C	0x0	<b>Attention Button Pressed.</b> Set when the attention button is pressed.
1	PFD	RW1C	0x0	<b>Power Fault Detected.</b> Set when the Power Controller detects a power fault.
2	MRLSC	RW1C	0x0	<b>MRL Sensor Changed.</b> Set when an MRL Sensor state change is detected.
3	PDC	RW1C	0x0	<b>Presence Detected Changed.</b> Set when a Presence Detected change is detected.

## Notes

Bit Field	Field Name	Type	Default Value	Description
4	CC	RW1C	0x0	<b>Command Completed.</b> This bit is set when the Hot-Plug Controller completes an issued command. If the bit is already set, then it remains set. A single write to the PCI Express Slot Control (PCIESCTL) register is considered to be a single command even if it affects more than one field in that register. This command completed bit is not set until processing of all actions associated with all fields in the PCIESCTL register have completed (i.e., all associated SMBus I/O expander transactions have completed).
5	MRLSS	RO	0x0	<b>MRL Sensor State.</b> This field enclosed the current state of the MRL sensor. 0x0 - (closed) MRL closed 0x1 - (open) MRL open
6	PDS	RO	0x1	<b>Presence Detect State.</b> This bit indicates the presence of a card in the slot corresponding to the port and reflects the state of the Presence Detect status. 0x0 - (empty) Slot empty 0x1 - (present) Card present
7	EIS	RO	0x0	<b>Electromechanical Interlock Status.</b> When an electromechanical interlock is implemented, this bit indicates the current status of the interlock. 0x0 - (disengaged) Electromechanical interlock disengaged 0x1 - (engaged) Electromechanical interlock engaged
8	DLLASC	RW1C	0x0	<b>Data Link Layer Link Active State Change.</b> This bit is set when the state of the data link layer active field in the link status register changes state. 0x0 - (nochange) No DLLLA state change 0x1 - (changed) DLLLA state change
15:9	Reserved	RO	0x0	Reserved field.

**PCIEDCAP2 - PCI Express Device Capabilities 2 (0x064)**

Bit Field	Field Name	Type	Default Value	Description
31:0	Reserved	RO	0x0	Reserved field.

**PCIEDCTL2 - PCI Express Device Control 2 (0x068)**

Bit Field	Field Name	Type	Default Value	Description
15:0	Reserved	RO	0x0	Reserved field.

## Notes

**PCIEDSTS2 - PCI Express Device Status 2 (0x06A)**

Bit Field	Field Name	Type	Default Value	Description
15:0	Reserved	RO	0x0	Reserved field.

**PCIELCAP2 - PCI Express Link Capabilities 2 (0x06C)**

Bit Field	Field Name	Type	Default Value	Description
31:0	Reserved	RO	0x0	Reserved field.

**PCIELCTL2 - PCI Express Link Control 2 (0x070)**

Bit Field	Field Name	Type	Default Value	Description
3:0	TLS	RW	0x2 Sticky	<b>Target Link Speed.</b> For downstream ports, this field sets an upper limit on the link operational speed by restricting the values advertised by the upstream component in its training sequences. For both upstream and downstream ports, this field is used to set the target compliance mode speed when software is using the ECOMP bit in this register to force a link into compliance mode. The PES16T4G2 supports 2.5 Gbps and 5.0 Gbps operation. Setting this field to an unsupported value produces undefined results. 0x1 - (gen1) 2.5 Gbps 0x2 - (gen2) 5.0 Gbps others- reserved
4	ECOMP	RW	0x0 Sticky	<b>Enter Compliance.</b> Software is permitted to force a link into compliance mode at the speed indicated by the TLS field by setting this bit in both components on a link and then initiating a hot reset on the link.
5	HASD	RO	0x0	<b>Hardware Autonomous Speed Disable.</b> When set, this bit prevents hardware from changing the link speed for device specific reasons other than to correct unreliable link operation by reducing the link speed. Initial transition to the highest supported common link speed is not blocked by this bit. The PES16T4G2 ports do not have an autonomous mechanism to regulate link speed, except due to link reliability issues. Therefore, this bit is not applicable to the PES16T4G2 ports. Note that this bit does not affect link speed changes triggered by software setting the target link speed and link-retrain bits. Refer to section Link Speed Negotiation in the PES16T4G2 on page 3-4 for further details.

## Notes

Bit Field	Field Name	Type	Default Value	Description
6	SDE	RWL	0x0	<p><b>Selectable De-emphasis.</b> For switch downstream ports, this bit sets the de-emphasis level when the link operates at 5.0 Gbps. For the upstream port, this bit selects the de-emphasis preference advertised via training sets (the actual de-emphasis on the link is selected by the link partner).</p> <p>0x0 - De-emphasis level = -6.0 dB 0x1 - De-emphasis level = -3.5 dB</p> <p>This bit has no effect when the link operates at 2.5 Gbps, or when the link operates in low-swing mode.</p> <p>When this field is modified, the newly selected de-emphasis is not applied until the PHY LTSSM transitions through the states in which it is allowed to modify the de-emphasis setting on the line (i.e., Recovery.Speed). Therefore, after modifying this field, it is recommended that the link be fully retrained by setting the FLRET bit in the PHYSTATE0 register.</p>
9:7	TM	RW	0x0 Sticky	<p><b>Transmit Margin.</b> This field controls the value of the non de-emphasized voltage level at the transmitter pins. This field is reset to 0x0 on entry to the LTSSM Polling.Configuration substate.</p> <p>0x0 - Normal operating range 0x1 - 900 mV for full swing and 500 mV for low-swing 0x2 - 700 mV for full swing and 400 mV for low-swing 0x3 - 500 mV for full swing and 300 mV for low-swing 0x4 - 300 mV for full swing and 200 mv for low-swing 0x5 - 200 mV for full swing and 100 mv for low-swing 0x6-0x7 - Reserved</p> <p>This register is intended for debug, compliance testing purpose only. System firmware and software is allowed to modify this register only during debug or compliance testing. In all other cases, the system must ensure that this register is set to the default value.</p>
10	EMC	RW	0x0 Sticky	<p><b>Enter Modified Compliance.</b> When this bit is set to 1b, the port transmits the modified compliance pattern if the LTSSM enters Polling.Compliance state.</p> <p>This register is intended for debug, compliance testing purposes only. System firmware and software is allowed to modify this register only during debug or compliance testing. In all other cases, the system must ensure that this register is set to the default value.</p>
11	CSOS	RW	0x0 Sticky	<p><b>Compliance SOS.</b> When set to 1b, the LTSSM is required to send SOS periodically in between the modified compliance patterns.</p>
12	CDE	RW	0x0 Sticky	<p><b>Compliance De-emphasis.</b> This bit selects the de-emphasis value in the Polling.Compliance state when this state was entered as a result of setting the Enter Compliance (ECOMP) bit in this register.</p> <p>0x0 - 6.0 dB 0x1 - 3.5 dB</p> <p>This bit is intended for debug, compliance testing purposes. System firmware and software is allowed to modify this bit only during debug or compliance testing.</p>
15:12	Reserved	RO	0x0	Reserved field.

## Notes

**PCIELSTS2 - PCI Express Link Status 2 (0x072)**

Bit Field	Field Name	Type	Default Value	Description
0	CDE	RO	0x0	Current De-emphasis. The value of this bit indicates the current de-emphasis level when the link operates in 5.0 Gbps. 0x0 - De-emphasis level = -6.0 dB 0x1 - De-emphasis level = -3.5 dB The value of this bit is undefined when the link operates at 2.5 Gbps.
15:1	Reserved	RO	0x0	Reserved field.

**PCIESCAP2 - PCI Express Slot Capabilities 2 (0x074)**

Bit Field	Field Name	Type	Default Value	Description
31:0	Reserved	RO	0x0	Reserved field.

**PCIESCTL2 - PCI Express Slot Control 2 (0x078)**

Bit Field	Field Name	Type	Default Value	Description
15:0	Reserved	RO	0x0	Reserved field.

**PCIESTS2 - PCI Express Slot Status 2 (0x07A)**

Bit Field	Field Name	Type	Default Value	Description
15:0	Reserved	RO	0x0	Reserved field.

## Power Management Capability Structure

**PMCAP - PCI Power Management Capabilities (0x0C0)**

Bit Field	Field Name	Type	Default Value	Description
7:0	CAPID	RO	0x1	<b>Capability ID.</b> The value of 0x1 identifies this capability as a PCI power management capability structure.
15:8	NXTPTR	RWL	Upstream: 0x0 Downstream: 0xD0	<b>Next Pointer.</b> This field contains a pointer to the next capability structure. For the upstream port the value of this field is 0x0 indicating that it is the last capability. For ports downstream ports, this field is 0xD0 and points to the MSI capability structure.



## Notes

Bit Field	Field Name	Type	Default Value	Description
18:16	VER	RO	0x3	<b>Power Management Capability Version.</b> This field indicates compliance with version two of the specification. Complies with version the PCI Bus Power Management Interface Specification, Revision 1.2.
19	PMECLK	RO	0x0	<b>PME Clock.</b> Does not apply to PCI Express.
20	Reserved	RO	0x0	Reserved field.
21	DEVSP	RWL	0x0	<b>Device Specific Initialization.</b> The value of zero indicates that no device specific initialization is required.
24:22	AUXI	RO	0x0	<b>AUX Current.</b> not used
25	D1	RO	0x0	<b>D1 Support.</b> This field indicates that the PES16T4G2 does not support D1.
26	D2	RO	0x0	<b>D2 Support.</b> This field indicates that the PES16T4G2 does not support D2.
31:27	PME	RWL	0b11001	<b>PME Support.</b> This field indicates the power states in which the port may generate a PME. Bits 27, 30 and 31 are set to indicate that the bridge will forward PME messages. The switch does not forward PME messages in D3 <sub>cold</sub> . This functionality may be supported in the system by routing WAKE# around the switch. Modification of this field modifies the advertised capability value but does not modify the device behavior (i.e., PME is generated in the states noted in the default value).

**PMCSR - PCI Power Management Control and Status (0x0C4)**

Bit Field	Field Name	Type	Default Value	Description
1:0	PSTATE	RW	0x0	<b>Power State.</b> This field is used to determine the current power state and to set a new power state. 0x0 - (d0) D0 state 0x1 - (d1) D1 state (not supported by the PES16T4G2 and reserved) 0x2- (d2) D2 state (not supported by the PES16T4G2 and reserved) 0x3 - (d3) D3 <sub>hot</sub> state
2	Reserved	RO	0x0	Reserved field.
3	NOSOFTRST	RWL	0x1	<b>No Soft Reset.</b> This bit indicates if the configuration context is preserved by the bridge when the device transitions from a D3 <sub>hot</sub> to D0 power management state. 0x0 - (reset) State reset 0x1 - (preserved) State preserved
7:4	Reserved	RO	0x0	Reserved field.

## Notes

Bit Field	Field Name	Type	Default Value	Description
8	PMEE	RW	0x0 Sticky	<b>PME Enable.</b> When this bit is set, PME message generation is enabled for the port. If a hot plug wake-up event is desired when exiting the D3 <sub>cold</sub> state, then this bit should be set during serial EEPROM initialization. A hot reset does not result in modification of this field.
12:9	DSEL	RO	0x0	<b>Data Select.</b> The optional data register is not implemented.
14:13	DSCALE	RO	0x0	<b>Data Scale.</b> The optional data register is not implemented.
15	PMES	RW1C	0x0 Sticky	<b>PME Status.</b> This bit is set if a PME is generated by the port even if the PMEE bit is cleared. This bit is not set when the bridge is propagating a PME message but the port is not itself generating a PME. Since the upstream port never generates a PME, this bit will never be set in that port.
21:16	Reserved	RO	0x0	Reserved field.
22	B2B3	RO	0x0	<b>B2/B3 Support.</b> Does not apply to PCI Express.
23	BPCCE	RO	0x0	<b>Bus Power/Clock Control Enable.</b> Does not apply to PCI Express.
31:24	DATA	RO	0x0	<b>Data.</b> This optional field is not implemented.

## Message Signaled Interrupt Capability Structure

## MSICAP - Message Signaled Interrupt Capability and Control (0x0D0)

Bit Field	Field Name	Type	Default Value	Description
7:0	CAPID	RO	0x5	<b>Capability ID.</b> The value of 0x5 identifies this capability as a MSI capability structure.
15:8	NXTPTR	RWL	0x0	<b>Next Pointer.</b> This field contains a pointer to the next capability structure. This field is set to 0x0 indicating that it is the last capability.
16	EN	RW	0x0	<b>Enable.</b> This bit enables MSI. 0x0 - (disable) disabled 0x1 - (enable) enabled
19:17	MMC	RO	0x0	<b>Multiple Message Capable.</b> This field contains the number of requested messages.
22:20	MME	RW	0x0	<b>Multiple Message Enable.</b> Hardwired to one message.
23	A64	RO	0x1	<b>64-bit Address Capable.</b> The bridge is capable of generating messages using a 64-bit address.
31:24	Reserved	RO	0x0	Reserved field.

## Notes

**MSIADDR - Message Signaled Interrupt Address (0x0D4)**

Bit Field	Field Name	Type	Default Value	Description
1:0	Reserved	RO	0x0	Reserved field.
31:2	ADDR	RW	0x0	<b>Message Address.</b> This field specifies the lower portion of the DWORD address of the MSI memory write transaction. The PES16T4G2 assumes that all downstream port generated MSIs are targeted to the root and routes these transactions to the upstream port. Configuring the address contained in a downstream port's MSIADDR and MSIADDRU registers to an address that does not route to the upstream port and generating an MSI produces undefined results.

**MSIUADDR - Message Signaled Interrupt Upper Address (0x0D8)**

Bit Field	Field Name	Type	Default Value	Description
31:0	UADDR	RW	0x0	<b>Upper Message Address.</b> This field specifies the upper portion of the DWORD address of the MSI memory write transaction. If the contents of this field are non-zero, then 64-bit address is used in the MSI memory write transaction. If the contents of this field are zero, then the 32-bit address specified in the MSIADDR field is used. The PES16T4G2 assumes that all downstream port generated MSIs are targeted to the root and routes these transactions to the upstream port. Configuring the address contained in a downstream port's MSIADDR and MSIADDRU registers to an address that does not route to the upstream port and generating an MSI produces undefined results.

**MSIMDATA - Message Signaled Interrupt Message Data (0x0DC)**

Bit Field	Field Name	Type	Default Value	Description
15:0	MDATA	RW	0x0	<b>Message Data.</b> This field contains the lower 16-bits of data that are written when a MSI is signalled.
31:16	Reserved	RO	0x0	Reserved field.

## Subsystem ID and Subsystem Vendor ID

**SSIDSSVIDCAP - Subsystem ID and Subsystem Vendor ID Capability (0x0F0)**

Bit Field	Field Name	Type	Default Value	Description
7:0	CAPID	RO	0xD	<b>Capability ID.</b> The value of 0xD identifies this capability as a SSID/SSVID capability structure.

## Notes

Bit Field	Field Name	Type	Default Value	Description
15:8	NXTPTR	RWL	0x00	<b>Next Pointer.</b> This field contains a pointer to the next capability structure.
31:16	Reserved	RO	0x0	Reserved field.

**SSIDSSVID - Subsystem ID and Subsystem Vendor ID (0x0F4)**

Bit Field	Field Name	Type	Default Value	Description
15:0	SSVID	RWL	0x0	<b>SubSystem Vendor ID.</b> This field identifies the manufacturer of the add-in card or subsystem. SSVID values are assigned by the PCI-SIG to insure uniqueness.
31:16	SSID	RWL	0x0	<b>Subsystem ID.</b> This field identifies the add-in card or subsystem. SSID values are assigned by the vendor.

## Extended Configuration Space Access Registers

**ECFGADDR - Extended Configuration Space Access Address (0x0F8)**

Bit Field	Field Name	Type	Default Value	Description
1:0	Reserved	RO	0x0	Reserved field.
7:2	REG	RW	0x0	<b>Register Number.</b> This field selects the configuration register number as defined by Section 7.2.2 of the PCI Express Base Specification, Rev. 1.0a
11:8	EREG	RW	0x0	<b>Extended Register Number.</b> This field selects the extended configuration register number as defined by Section 7.2.2 of the PCI Express Base Specification, Rev. 1.0a
31:12	Reserved	RO	0x0	Reserved field.

**ECFGDATA - Extended Configuration Space Access Data (0x0FC)**

Bit Field	Field Name	Type	Default Value	Description
31:0	DATA	RW	0x0	<b>Configuration Data.</b> A read from this field will return the configuration space register value pointed to by the ECFGADDR register. A write to this field will update the contents of the configuration space register pointed to by the ECFGADDR register with the value written. For both reads and writes, the byte enables correspond to those used to access this field. When the ECFGADDR register points to the ECFGDATA register, then reads from ECFGDATA return zero and writes are ignored. When the ECFGADDR register points to itself, writes to the ECFGDATA register modify the contents of the ECFGADDR register. SMBus reads of this field return a value of zero and SMBus writes have no effect.

## Notes

## Advanced Error Reporting (AER) Enhanced Capability

## AERCAP - AER Capabilities (0x100)

Bit Field	Field Name	Type	Default Value	Description
15:0	CAPID	RO	0x1	<b>Capability ID.</b> The value of 0x1 indicates an advanced error reporting capability structure.
19:16	CAPVER	RO	0x1	<b>Capability Version.</b> The value of 0x1. indicates compatibility with version 1 of the specification.
31:20	NXTPTR	RWL	0x200	Next Pointer.

## AERUES - AER Uncorrectable Error Status (0x104)

Bit Field	Field Name	Type	Default Value	Description
0	UDEF	RW1C	0x0 Sticky	<b>Undefined.</b> This bit is no longer used in this version of the specification.
3:1	Reserved	RO	0x0	Reserved field.
4	DLPERR	RW1C	0x0 Sticky	<b>Data Link Protocol Error Status.</b> This bit is set when a data link layer protocol error is detected.
5	SDOENERR	RW1C	0x0 Sticky	<b>Surprise Down Error Status.</b> This bit is set when a surprise down error is detected and the SDERR bit in the PCIELCAP register is set.
11:6	Reserved	RO	0x0 Sticky	Reserved field.
12	POISONED	RW1C	0x0 Sticky	<b>Poisoned TLP Status.</b> This bit is set when a poisoned TLP is detected.
13	FCPERR	RW1C	0x0 Sticky	<b>Flow Control Protocol Error Status.</b> This bit is set when a flow control protocol error is detected.
14	COMPTO	RO	0x0	<b>Completion Time-out Status.</b> A switch port does not initiate non-posted requests on its own behalf. Therefore, this field is hardwired to zero.
15	CABORT	RO	0x0	<b>Completer Abort Status.</b> The PES16T4G2 never responds to a non-posted request with a completer abort.
16	UECOMP	RW1C	0x0 Sticky	<b>Unexpected Completion Status.</b> This bit is set when an unexpected completion is detected.
17	RCVOVR	RW1C	0x0 Sticky	<b>Receiver Overflow Status.</b> This bit is set when a receiver overflow is detected.
18	MALFORMED	RW1C	0x0 Sticky	<b>Malformed TLP Status.</b> This bit is set when a malformed TLP is detected.
19	ECRC	RW1C	0x0 Sticky	<b>ECRC Status.</b> This bit is set when an ECRC error is detected.
20	UR	RW1C	0x0 Sticky	<b>UR Status.</b> This bit is set when an unsupported request is detected.

## Notes

Bit Field	Field Name	Type	Default Value	Description
21	ACSV	RW1C	0x0 Sticky	ACS Violation Status. This bit is set when an ACS violation is detected on the port. The PES16T4G2 does not support ACS and therefore this bit is hardwired to 0x0.
31:22	Reserved	RO	0x0	Reserved field.

**AERUEM - AER Uncorrectable Error Mask (0x108)**

Bit Field	Field Name	Type	Default Value	Description
0	UDEF	RW	0x0 Sticky	<b>Undefined.</b> This bit is no longer used in this version of the specification.
3:1	Reserved	RO	0x0	Reserved field.
4	DLPERR	RW	0x0 Sticky	<b>Data Link Protocol Error Mask.</b> When this bit is set, the corresponding bit in the AERUES register is masked. When a bit is masked in the AERUES register, the corresponding event is not logged in the advanced capability structure, the First Error Pointer field (FEPTR) in the AERCTL register is not updated, and an error is not reported to the root complex. This bit does not affect the state of the corresponding bit in the AERUES register.
5	SDOENERR	RW	0x0 Sticky	<b>Surprise Down Error Mask.</b> When this bit is set, the corresponding bit in the AERUES register is masked. When a bit is masked in the AERUES register, the corresponding event is not logged in the advanced capability structure, the First Error Pointer field (FEPTR) in the AERCTL register is not updated, and an error is not reported to the root complex. This bit does not affect the state of the corresponding bit in the AERUES register.
11:6	Reserved	RO	0x0	Reserved field.
12	POISONED	RW	0x0 Sticky	<b>Poisoned TLP Mask.</b> When this bit is set, the corresponding bit in the AERUES register is masked. When a bit is masked in the AERUES register, the corresponding event is not logged in the advanced capability structure, the First Error Pointer field (FEPTR) in the AERCTL register is not updated, and an error is not reported to the root complex. This bit does not affect the state of the corresponding bit in the AERUES register.
13	FCPERR	RW	0x0 Sticky	<b>Flow Control Protocol Error Mask.</b> When this bit is set, the corresponding bit in the AERUES register is masked. When a bit is masked in the AERUES register, the corresponding event is not logged in the advanced capability structure, the First Error Pointer field (FEPTR) in the AERCTL register is not updated, and an error is not reported to the root complex. This bit does not affect the state of the corresponding bit in the AERUES register.
14	COMPTO	RO	0x0	<b>Completion Time-out Mask.</b> A switch port does not initiate non-posted requests on its own behalf. Therefore, this field is hardwired to zero.

## Notes

Bit Field	Field Name	Type	Default Value	Description
15	CABORT	RO	0x0	<b>Completer Abort Mask.</b> The PES16T4G2 never responds to a non-posted request with a completer abort.
16	UECOMP	RW	0x0 Sticky	<b>Unexpected Completion Mask.</b> When this bit is set, the corresponding bit in the AERUES register is masked. When a bit is masked in the AERUES register, the corresponding event is not logged in the advanced capability structure, the First Error Pointer field (FEPTR) in the AERCTL register is not updated, and an error is not reported to the root complex. This bit does not affect the state of the corresponding bit in the AERUES register.
17	RCVOVR	RW	0x0 Sticky	<b>Receiver Overflow Mask.</b> When this bit is set, the corresponding bit in the AERUES register is masked. When a bit is masked in the AERUES register, the corresponding event is not logged in the advanced capability structure, the First Error Pointer field (FEPTR) in the AERCTL register is not updated, and an error is not reported to the root complex. This bit does not affect the state of the corresponding bit in the AERUES register.
18	MALFORMED	RW	0x0 Sticky	<b>Malformed TLP Mask.</b> When this bit is set, the corresponding bit in the AERUES register is masked. When a bit is masked in the AERUES register, the corresponding event is not logged in the advanced capability structure, the First Error Pointer field (FEPTR) in the AERCTL register is not updated, and an error is not reported to the root complex. This bit does not affect the state of the corresponding bit in the AERUES register.
19	ECRC	RW	0x0 Sticky	<b>ECRC Mask.</b> When this bit is set, the corresponding bit in the AERUES register is masked. When a bit is masked in the AERUES register, the corresponding event is not logged in the advanced capability structure, the First Error Pointer field (FEPTR) in the AERCTL register is not updated, and an error is not reported to the root complex. This bit does not affect the state of the corresponding bit in the AERUES register.
20	UR	RW	0x0 Sticky	<b>UR Mask.</b> When this bit is set, the corresponding bit in the AERUES register is masked. When a bit is masked in the AERUES register, the corresponding event is not logged in the advanced capability structure, the First Error Pointer field (FEPTR) in the AERCTL register is not updated, and an error is not reported to the root complex. This bit does not affect the state of the corresponding bit in the AERUES register.
21	ACSV	RW	0x0 Sticky	<b>ACS Violation Mask.</b> When this bit is set, the corresponding bit in the AERUES register is masked. When a bit is masked in the AERUES register, the corresponding event is not logged in the advanced capability structure, the First Error Pointer field (FEPTR) in the AERCTL register is not updated, and an error is not reported to the root complex. This bit does not affect the state of the corresponding bit in the AERUES register.
31:22	Reserved	RO	0x0	Reserved field.

## Notes

## AERUESV - AER Uncorrectable Error Severity (0x10C)

Bit Field	Field Name	Type	Default Value	Description
0	UDEF	RW	0x0 Sticky	<b>Undefined.</b> This bit is no longer used in this version of the specification.
3:1	Reserved	RO	0x0	Reserved field.
4	DLPERR	RW	0x1 Sticky	<b>Data Link Protocol Error Severity.</b> If the corresponding event is not masked in the AERUEM register, then when the event occurs, this bit controls the severity of the reported error. If this bit is set, the event is reported as a fatal error. When this bit is cleared, the event is reported as an uncorrectable error.
5	SDOENERR	RW	0x1 Sticky	<b>Surprise Down Error Severity.</b> If the corresponding event is not masked in the AERUEM register, then when the event occurs, this bit controls the severity of the reported error. If this bit is set, the event is reported as a fatal error. When this bit is cleared, the event is reported as an uncorrectable error.
11:6	Reserved	RO	0x0	Reserved field.
12	POISONED	RW	0x0 Sticky	<b>Poisoned TLP Status Severity.</b> If the corresponding event is not masked in the AERUEM register, then when the event occurs, this bit controls the severity of the reported error. If this bit is set, the event is reported as a fatal error. When this bit is cleared, the event is reported as an uncorrectable error.
13	FCPERR	RW	0x1 Sticky	<b>Flow Control Protocol Error Severity.</b> If the corresponding event is not masked in the AERUEM register, then when the event occurs, this bit controls the severity of the reported error. If this bit is set, the event is reported as a fatal error. When this bit is cleared, the event is reported as an uncorrectable error.
14	COMPTO	RO	0x0	<b>Completion Time-out Severity.</b> A switch port does not initiate non-posted requests on its own behalf. Therefore, this field is hardwired to zero.
15	CABORT	RO	0x0	<b>Completer Abort Severity.</b> The PES16T4G2 never responds to a non-posted request with a completer abort.
16	UECOMP	RW	0x0 Sticky	<b>Unexpected Completion Severity.</b> If the corresponding event is not masked in the AERUEM register, then when the event occurs, this bit controls the severity of the reported error. If this bit is set, the event is reported as a fatal error. When this bit is cleared, the event is reported as an uncorrectable error.
17	RCVOVR	RW	0x1 Sticky	<b>Receiver Overflow Severity.</b> If the corresponding event is not masked in the AERUEM register, then when the event occurs, this bit controls the severity of the reported error. If this bit is set, the event is reported as a fatal error. When this bit is cleared, the event is reported as an uncorrectable error.
18	MALFORMED	RW	0x1 Sticky	<b>Malformed TLP Severity.</b> If the corresponding event is not masked in the AERUEM register, then when the event occurs, this bit controls the severity of the reported error. If this bit is set, the event is reported as a fatal error. When this bit is cleared, the event is reported as an uncorrectable error.



## Notes

Bit Field	Field Name	Type	Default Value	Description
19	ECRC	RW	0x0 Sticky	<b>ECRC Severity.</b> If the corresponding event is not masked in the AERUEM register, then when the event occurs, this bit controls the severity of the reported error. If this bit is set, the event is reported as a fatal error. When this bit is cleared, the event is reported as an uncorrectable error.
20	UR	RW	0x0 Sticky	<b>UR Severity.</b> If the corresponding event is not masked in the AERUEM register, then when the event occurs, this bit controls the severity of the reported error. If this bit is set, the event is reported as a fatal error. When this bit is cleared, the event is reported as an uncorrectable error.
21	ACSV	RW	0x0 Sticky	<b>ACS Violation Severity.</b> If the corresponding event is not masked in the AERUEM register, then when the event occurs, this bit controls the severity of the reported error. If this bit is set, the event is reported as a fatal error. When this bit is cleared, the event is reported as an uncorrectable error.
31:22	Reserved	RO	0x0	Reserved field.

**AERCES - AER Correctable Error Status (0x110)**

Bit Field	Field Name	Type	Default Value	Description
0	RCVERR	RW1C	0x0 Sticky	<b>Receiver Error Status.</b> This bit is set when the physical layer detects a receiver error.
5:1	Reserved	RO	0x0	Reserved field.
6	BADTLP	RW1C	0x0 Sticky	<b>Bad TLP Status.</b> This bit is set when a bad TLP is detected.
7	BADDLLP	RW1C	0x0 Sticky	<b>Bad DLLP Status.</b> This bit is set when a bad DLLP is detected.
8	RPLYROVR	RW1C	0x0 Sticky	<b>Replay Number Rollover Status.</b> This bit is set when a replay number rollover has occurred indicating that the data link layer has abandoned replays and has requested that the link be retrained.
11:9	Reserved	RO	0x0	Reserved field.
12	RPLYTO	RW1C	0x0 Sticky	<b>Replay Timer Time-Out Status.</b> This bit is set when the replay timer in the data link layer times out.
13	ADVISORYNF	RW1C	0x0 Sticky	<b>Advisory Non-Fatal Error Status.</b> This bit is set when an advisory non-fatal error is detected as described in Section 6.2.3.2.4 of the PCIe base 1.1 specification.
31:14	Reserved	RO	0x0	Reserved field.

## Notes

**AERCCEM - AER Correctable Error Mask (0x114)**

Bit Field	Field Name	Type	Default Value	Description
0	RCVERR	RW	0x0 Sticky	<b>Receiver Error Mask.</b> When this bit is set, the corresponding bit in the AERCES register is masked. When a bit is masked in the AERCES register, the corresponding event is not reported to the root complex.
5:1	Reserved	RO	0x0	Reserved field.
6	BADTLP	RW	0x0 Sticky	<b>Bad TLP Mask.</b> When this bit is set, the corresponding bit in the AERCES register is masked. When a bit is masked in the AERCES register, the corresponding event is not reported to the root complex.
7	BADDLLP	RW	0x0 Sticky	<b>Bad DLLP Mask.</b> When this bit is set, the corresponding bit in the AERCES register is masked. When a bit is masked in the AERCES register, the corresponding event is not reported to the root complex.
8	RPLYROVR	RW	0x0 Sticky	<b>Replay Number Rollover Mask.</b> When this bit is set, the corresponding bit in the AERCES register is masked. When a bit is masked in the AERCES register, the corresponding event is not reported to the root complex.
11:9	Reserved	RO	0x0	Reserved field.
12	RPLYTO	RW	0x0 Sticky	<b>Replay Timer Time-Out Mask.</b> When this bit is set, the corresponding bit in the AERCES register is masked. When a bit is masked in the AERCES register, the corresponding event is not reported to the root complex.
13	ADVISO-RYNF	RW	0x1 Sticky	<b>Advisory Non-Fatal Error Mask.</b> When this bit is set, the corresponding bit in the AERCES register is masked. When a bit is masked in the AERCES register, the corresponding event is not reported to the root complex.
31:14	Reserved	RO	0x0	Reserved field.

**AERCTL - AER Control (0x118)**

Bit Field	Field Name	Type	Default Value	Description
4:0	FEPTR	RO	0x0 Sticky	<b>First Error Pointer.</b> This field contains a pointer to the bit in the AERUES register that resulted in the first reported error.
5	ECRCGC	RWL	0x1	<b>ECRC Generation Capable.</b> This bit indicates if the device is capable of generating ECRC.
6	ECRCGE	RW	0x0 Sticky	<b>ECRC Generation Enable.</b> When this bit is set, ECRC generation is enabled.
7	ECRCCC	RWL	0x1	<b>ECRC Check Capable.</b> This bit indicates if the device is capable of checking ECRC.
8	ECRCCE	RW	0x0 Sticky	<b>ECRC Check Enable.</b> When set, this bit enables ECRC checking.
31:9	Reserved	RO	0x0	Reserved field.

## Notes

**AERHL1DW - AER Header Log 1st Doubleword (0x11C)**

Bit Field	Field Name	Type	Default Value	Description
31:0	HL	RO	0x0 Sticky	<b>Header Log.</b> This field contains the 1st doubleword of the TLP header that resulted in the first reported uncorrectable error.

**AERHL2DW - AER Header Log 2nd Doubleword (0x120)**

Bit Field	Field Name	Type	Default Value	Description
31:0	HL	RO	0x0 Sticky	<b>Header Log.</b> This field contains the 2nd doubleword of the TLP header that resulted in the first reported uncorrectable error.

**AERHL3DW - AER Header Log 3rd Doubleword (0x124)**

Bit Field	Field Name	Type	Default Value	Description
31:0	HL	RO	0x0 Sticky	<b>Header Log.</b> This field contains the 3rd doubleword of the TLP header that resulted in the first reported uncorrectable error.

**AERHL4DW - AER Header Log 4th Doubleword (0x128)**

Bit Field	Field Name	Type	Default Value	Description
31:0	HL	RO	0x0 Sticky	<b>Header Log.</b> This field contains the 4th doubleword of the TLP header that resulted in the first reported uncorrectable error.

## Device Serial Number Enhanced Capability

**SNUMCAP - Serial Number Capabilities (0x180)**

Bit Field	Field Name	Type	Default Value	Description
15:0	CAPID	RO	0x3	<b>Capability ID.</b> The value of 0x3 indicates a device serial number capability structure.
19:16	CAPVER	RO	0x1	<b>Capability Version.</b> The value of 0x1. indicates compatibility with version 1 of the specification.
31:20	NXTPTR	RWL	0x0	Next Pointer.

**SNUMLDW - Serial Number Lower Doubleword (0x184)**

Bit Field	Field Name	Type	Default Value	Description
31:0	SNUM	RWL	0x0 Sticky	<b>Lower 32-bits of Device Serial Number.</b> This field contains the lower 32-bits of the IEEE defined 64-bit extended unique identifier (EUI-64) assigned to the device.

## Notes

**SNUMUDW - Serial Number Upper Doubleword (0x188)**

Bit Field	Field Name	Type	Default Value	Description
31:0	SNUM	RWL	0x0 Sticky	<b>Upper 32-bits of Device Serial Number.</b> This field contains the upper 32-bits of the IEEE defined 64-bit extended unique identifier (EUI-64) assigned to the device.

## PCI Express Virtual Channel Capability

**PCIEVCECAP - PCI Express VC Enhanced Capability Header (0x200)**

Bit Field	Field Name	Type	Default Value	Description
15:0	CAPID	RO	0x2	<b>Capability ID.</b> The value of 0x2. indicates a virtual channel capability structure.
19:16	CAPVER	RO	0x1	<b>Capability Version.</b> The value of 0x1. indicates compatibility with version 1 of the specification.
31:20	NXTPTR	RWL	0x0	<b>Next Pointer.</b> The value of 0x0 indicates that there are no extended capabilities.

**PVCCAP1- Port VC Capability 1 (0x204)**

Bit Field	Field Name	Type	Default Value	Description
2:0	EVCCNT	RO	0x0	<b>Extended VC Count.</b> The value 0x0 indicates only implementation of the default VC.
3	Reserved	RO	0x0	Reserved field.
6:4	LPEVCCNT	RO	0x0	<b>Low Priority Extended VC Count.</b> The value of 0x0 indicates only implementation of the default VC.
7	Reserved	RO	0x0	Reserved field.
9:8	REFCLK	RO	0x0	<b>Reference Clock.</b> WRR is not implemented.
11:10	PATBSIZ	RO	Upstream: 0x2 Downstream: 0x0	<b>Port Arbitration Table Entry Size.</b> This field indicates the size of the port arbitration table in the device. For the upstream port, the is set to 0x2 to indicate a table with 4-bit entries. For downstream ports, this value is set to 0x0. 0x0 - (bit1) Port arbitration table is 1-bit 0x1 - (bit2) Port arbitration table is 2-bits 0x2 - ((bit4) Port arbitration table is 4-bits 0x3 - (bit8) Port arbitration table is 8-bits
31:12	Reserved	RO	0x0	Reserved field.

## Notes

**PVCCAP2 - Port VC Capability 2 (0x208)**

Bit Field	Field Name	Type	Default Value	Description
7:0	VCARBCAP	RO	0x0	<b>VC Arbitration Capability.</b> This field indicates the type of VC arbitration that is supported by the port for the low priority VC group. This field is valid for all ports that report a low priority extended VC count greater than zero. Each bit in this field corresponds to a VC arbitration capability. bit 0 - hardware fixed arbitration (i.e., round robin) bit 1 - weighted round robin (WRR) with 32 phases bit 2 - weighted round robin (WRR) with 64 phases bit 3 - weighted round robin (WRR) with 128 phases bits 4 through 7 - reserved
23:8	Reserved	RO	0x0	Reserved field.
31:24	VCATBLOFF	RO	0x0	<b>VC Arbitration Table Offset.</b> This field contains the offset of the VC arbitration table from the base address of the Virtual Channel Capability structure in double quad words (16 bytes). The value of zero indicates that the VC arbitration table is not present.

**PVCCTL - Port VC Control (0x20C)**

Bit Field	Field Name	Type	Default Value	Description
0	LVCAT	RO	0x0	<b>Load VC Arbitration Table.</b> This bit, when set, updates the VC arbitration logic from the VC Arbitration Table for the VC resource. Since the device does not implement a VC arbitration table, this field has no functional effect. This bit always returns 0 when read.
3:1	VCARBSEL	RW	0x0	<b>VC Arbitration Select.</b> This field configures the VC arbitration by selecting one of the supported arbitration schemes indicated by the VC arbitration capability field (i.e., the VCARBCAP field in the PVCCAP2 register). Since the device supports only VC0, this field has no functional effect.
15:4	Reserved	RO	0x0	Reserved field.

**PVCSTS - Port VC Status (0x20E)**

Bit Field	Field Name	Type	Default Value	Description
0	VCATS	RO	0x0	<b>VC Arbitration Table Status.</b> This bit indicates the coherency status of the VC arbitration table. Since the device supports only VC0, this field has no functional effect and is always zero.
15:1	Reserved	RO	0x0	Reserved field.

## Notes

## VCR0CAP- VC Resource 0 Capability (0x210)

Bit Field	Field Name	Type	Default Value	Description
7:0	PARBC	RO	Upstream: 0x3 Downstream: 0x1	<b>Port Arbitration Capability.</b> This field indicates the type of port arbitration supported by the VC. Each bit corresponds to a Port Arbitration capability. When more than one arbitration scheme is supported, multiple bits may be set. The upstream port supports hardware fixed round robin and weighted round robin with 32 phases. Downstream ports support only hardware fixed round robin. bit 0 - hardware fixed round robin bit 1 - weighted round robin with 32 phases bit 2 - weighted round robin with 64 phases bit 3 - weighted round robin with 128 phases bit 4 - time-based weighted round robin with 128 phases bit 5 - weighted round robin with 256 phases
13:8	Reserved	RO	0x0	Reserved field.
14	APS	RO	0x0	<b>Advanced Packet Switching.</b> Not supported.
15	RJST	RO	0x0	<b>Reject Snoop Transactions.</b> No supported for switch ports.
22:16	MAXTS	RO	0x0	<b>Maximum Time Slots.</b> Since this VC does not support time-based WRR, this field is not valid.
23	Reserved	RO	0x0	Reserved field.
31:24	PATBLOFF	RO	Upstream: 0x2 Downstream: 0x0	<b>Port Arbitration Table Offset.</b> This field contains the offset of the port arbitration table from the base address of the Virtual Channel Capability structure in double quad words (16 bytes). The upstream port has a port arbitration table. Downstream ports do not have a port arbitration table.

## VCR0CTL- VC Resource 0 Control (0x214)

Bit Field	Field Name	Type	Default Value	Description
7:0	TCVCMAP	bit 0 RO bits 1 through 7 RW	0xFF	<b>TC/VC Map.</b> This field indicates the TCs that are mapped to the VC resource. Each bit corresponds to a TC. When a bit is set, the corresponding TC is mapped to the VC.
15:8	Reserved	RO	0x0	Reserved field.
16	LPAT	RW	0x0	<b>Load Port Arbitration Table.</b> This bit, when set, updates the Port Arbitration logic from the Port Arbitration Table for the VC resource. In addition, this field is only valid when the Port Arbitration Table is used by the selected Port Arbitration scheme (that is indicated by a set bit in the Port Arbitration Capability field selected by Port Arbitration Select). Software sets this bit to signal hardware to update Port Arbitration logic with new values stored in Port Arbitration Table; clearing this bit has no effect. Software uses the Port Arbitration Table Status bit to confirm whether the new values of Port Arbitration Table are completely latched by the arbitration logic. This bit only has an effect in the upstream port. This bit always returns 0 when read.

## Notes

Bit Field	Field Name	Type	Default Value	Description
19:17	PARBSEL	RW	0x0	<b>Port Arbitration Select.</b> This field configures the VC resource to provide a particular Port Arbitration service. The permissible values of this field is a number that corresponds to one of the asserted bits in the Port Arbitration Capability field of the VC resource.
23:20	Reserved	RO	0x0	Reserved field.
26:24	VCID	RO	0x0	<b>VC ID.</b> This field assigns a VC ID to the VC resource. Since the PES16T4G2 implements only a single VC, this field is hardwired to zero.
30:27	Reserved	RO	0x0	Reserved field.
31	VCEN	RO	0x1	<b>VC Enable.</b> This field, when set, enables a virtual channel. Since the PES16T4G2 implements only a single VC, this field is hardwired to one (enabled).

**VCR0STS - VC Resource 0 Status (0x218)**

Bit Field	Field Name	Type	Default Value	Description
15:0	Reserved	RO	0x0	Reserved field.
16	PATS	RO	0x0	<b>Port Arbitration Table Status.</b> This bit indicates the coherency status of the port arbitration table associated with the VC resource and is valid only when the port arbitration table is used by the selected arbitration algorithm. This bit is set when any entry of the port arbitration table is written by software and remains set until hardware finishes loading the value after software sets the LPAT field in the VCR0CTL register. This field is always zero for downstream ports.
17	VCNEG	RO	0x0	<b>VC Negotiation Pending.</b> Since the PES16T4G2 implements only a single VC (i.e., the default VC) this field indicates the status of the process of flow control initialization. This bit is cleared by hardware after the VC negotiation is complete (on exit from the FC_INIT2 state). The value of this field is defined only when the Link is in the DL_Active state and the Virtual Channel is enabled (its VC Enable bit is Set).
31:18	Reserved	RO	0x0	Reserved field.

## Notes

## VCR0TBL0 - VC Resource 0 Arbitration Table Entry 0 (0x220)

Bit Field	Field Name	Type	Default Value	Description
3:0	PHASE0	RW	0x2	<b>Phase 0.</b> This field contains the port ID for the corresponding port arbitration period. Selecting an invalid port ID results in the entry being skipped without delay. The port arbitration behavior when this field contains an illegal value (i.e., reserved or the egress port ID) is undefined. 0x0 - (port_0) Port 0 (upstream port) 0x1 - Reserved 0x2 - (port_2) Port 2 0x3 - Reserved 0x4 - (port_4) Port 4 0x5 - Reserved 0x6 - (port_6) Port 6 0x7 - Reserved 0x8 through 0xF - Reserved
7:4	PHASE1	RW	0x4	<b>Phase 1.</b> This field contains the port ID for the corresponding port arbitration period.
11:8	PHASE2	RW	0x6	<b>Phase 2.</b> This field contains the port ID for the corresponding port arbitration period.
15:12	PHASE3	RW	0x2	<b>Phase 3.</b> This field contains the port ID for the corresponding port arbitration period.
19:16	PHASE4	RW	0x4	<b>Phase 4.</b> This field contains the port ID for the corresponding port arbitration period.
23:20	PHASE5	RW	0x6	<b>Phase 5.</b> This field contains the port ID for the corresponding port arbitration period.
27:24	PHASE6	RW	0x2	<b>Phase 6.</b> This field contains the port ID for the corresponding port arbitration period.
31:28	PHASE7	RW	0x4	<b>Phase 7.</b> This field contains the port ID for the corresponding port arbitration period.

## VCR0TBL1 - VC Resource 0 Arbitration Table Entry 1 (0x224)

Bit Field	Field Name	Type	Default Value	Description
3:0	PHASE8	RW	0x6	<b>Phase 8.</b> This field contains the port ID for the corresponding port arbitration period.
7:4	PHASE9	RW	0x2	<b>Phase 9.</b> This field contains the port ID for the corresponding port arbitration period.
11:8	PHASE10	RW	0x4	<b>Phase 10.</b> This field contains the port ID for the corresponding port arbitration period.
15:12	PHASE11	RW	0x6	<b>Phase 11.</b> This field contains the port ID for the corresponding port arbitration period.
19:16	PHASE12	RW	0x2	<b>Phase 12.</b> This field contains the port ID for the corresponding port arbitration period.



## Notes

Bit Field	Field Name	Type	Default Value	Description
23:20	PHASE13	RW	0x4	<b>Phase 13.</b> This field contains the port ID for the corresponding port arbitration period.
27:24	PHASE14	RW	0x6	<b>Phase 14.</b> This field contains the port ID for the corresponding port arbitration period.
31:28	PHASE15	RW	0x2	<b>Phase 15.</b> This field contains the port ID for the corresponding port arbitration period.

**VCR0TBL2 - VC Resource 0 Arbitration Table Entry 2 (0x228)**

Bit Field	Field Name	Type	Default Value	Description
3:0	PHASE16	RW	0x4	<b>Phase 16.</b> This field contains the port ID for the corresponding port arbitration period.
7:4	PHASE17	RW	0x6	<b>Phase 17.</b> This field contains the port ID for the corresponding port arbitration period.
11:8	PHASE18	RW	0x2	<b>Phase 18.</b> This field contains the port ID for the corresponding port arbitration period.
15:12	PHASE19	RW	0x4	<b>Phase 19.</b> This field contains the port ID for the corresponding port arbitration period.
19:16	PHASE20	RW	0x6	<b>Phase 20.</b> This field contains the port ID for the corresponding port arbitration period.
23:20	PHASE21	RW	0x2	<b>Phase 21.</b> This field contains the port ID for the corresponding port arbitration period.
27:24	PHASE22	RW	0x4	<b>Phase 22.</b> This field contains the port ID for the corresponding port arbitration period.
31:28	PHASE23	RW	0x6	<b>Phase 23.</b> This field contains the port ID for the corresponding port arbitration period.

**VCR0TBL3 - VC Resource 0 Arbitration Table Entry 3 (0x22C)**

Bit Field	Field Name	Type	Default Value	Description
3:0	PHASE24	RW	0x2	<b>Phase 24.</b> This field contains the port ID for the corresponding port arbitration period.
7:4	PHASE25	RW	0x4	<b>Phase 25.</b> This field contains the port ID for the corresponding port arbitration period.
11:8	PHASE26	RW	0x6	<b>Phase 26.</b> This field contains the port ID for the corresponding port arbitration period.
15:12	PHASE27	RW	0x2	<b>Phase 27.</b> This field contains the port ID for the corresponding port arbitration period.
19:16	PHASE28	RW	0x4	<b>Phase 28.</b> This field contains the port ID for the corresponding port arbitration period.

## Notes

Bit Field	Field Name	Type	Default Value	Description
23:20	PHASE29	RW	0x6	<b>Phase 29.</b> This field contains the port ID for the corresponding port arbitration period.
27:24	PHASE30	RW	0x2	<b>Phase 30.</b> This field contains the port ID for the corresponding port arbitration period.
31:28	PHASE31	RW	0x4	<b>Phase 31.</b> This field contains the port ID for the corresponding port arbitration period.

## Power Budgeting Enhanced Capability

**PWRBCAP - Power Budgeting Capabilities (0x280)**

Bit Field	Field Name	Type	Default Value	Description
15:0	CAPID	RWL	0x0	<b>Capability ID.</b> The value of 0x4 indicates a power budgeting capability structure. If the power budgeting capability is used, then this field should be initialized with data from a serial EEPROM.
19:16	CAPVER	RWL	0x0	<b>Capability Version.</b> The value of 0x1. indicates compatibility with version 1 of the specification. If the power budgeting capability is used, then this field should be initialized with data from a serial EEPROM.
31:20	NXTPTR	RWL	0x0	Next Pointer.

**PWRBDSEL - Power Budgeting Data Select (0x284)**

Bit Field	Field Name	Type	Default Value	Description
7:0	DVSEL	RW	0x0	<b>Data Value Select.</b> This field selects the Power Budgeting Data Value (PWRBDVx) register whose contents are reported in the Data (DATA) field of the Power Budgeting Data (PWRBD) register. Setting this field to a value greater than 7, causes zero to be returned in the DATA field of the PWRBD register.
31:8	Reserved	RO	0x0	Reserved field.

**PWRBD - Power Budgeting Data (0x288)**

Bit Field	Field Name	Type	Default Value	Description
31:0	DATA	RO	0x0	<b>Data.</b> If the Data Value Select (DVSEL) field in the Power Budgeting Data Select register contains a value of zero through 7, then this field returns the contents of the corresponding Power Budgeting Data Value (PWRBDVx) register. Otherwise, this field contains a value of zero.

## Notes

**PWRBPBC - Power Budgeting Power Budget Capability (0x28C)**

Bit Field	Field Name	Type	Default Value	Description
0	SA	RWL	0x0	<b>System Allocated.</b> When this bit is set, it indicates that the power budget for the device is included within the system power budget and that reported power data for this device should be ignored. If the power budgeting capability is used, then this field should be initialized with data from a serial EEPROM.
31:1	Reserved	RO	0x0	Reserved field.

**PWRBDV[7:0] - Power Budgeting Data Value [7:0] (0x300 - 0X31C)**

Bit Field	Field Name	Type	Default Value	Description
31:0	DV	RW	Undefined Sticky	<b>Data Value.</b> This 32-bit field is used to hold power budget data in the format described in Section 7.15.3 in the PCIe 2.0 Base Specification. This field may be read and written when the Power Budgeting Data Value Unlock (PWRBDVUL) bit is set in the Switch Control (SWCTL) register. When the PWRBDVUL bit is cleared, this register is read-only and writes are ignored. If the power budgeting capability is used, then this field should be initialized with data from a serial EEPROM.

## Switch Status and Control Registers

**SWSTS - Switch Status (0x400)**

Bit Field	Field Name	Type	Default Value	Description
2:0	SWMODE	RO	HWINIT	<b>Switch Mode.</b> These configuration pins determine the Whitney switch operating mode. 0x0 - Normal Switch Mode 0x1 - Normal Switch Mode with Serial EEPROM initialization 0x2 - 0x7 Reserved
4:3	Reserved	RO	0x0	Reserved field.
5	CCLKDS	RO	HWINIT	<b>Common Clock Downstream.</b> This bit reflects the value of the CCLKDS signal sampled during Fundamental Reset.
6	CCLKUS	RO	HWINIT	<b>Common Clock Upstream.</b> This bit reflects the value of the CCLKUS signal sampled during Fundamental Reset.
7	MSMB-SMODE	RO	HWINIT	<b>Master SMBus Slow Mode.</b> This bit reflects the value of the MSMBSMODE signal sampled during Fundamental Reset.
8	REFCLKM	RO	HWINIT	<b>PCI Express Reference Clock Mode Select.</b> This bit reflects the value of the REFCLKM signal sampled during Fundamental Reset.
9	RSTHALT	RO	HWINIT	<b>Reset Halt.</b> This bit reflects the value of the RSTHALT signal sampled during Fundamental Reset.

## Notes

Bit Field	Field Name	Type	Default Value	Description
31:10	Reserved	RO	0x0	Reserved field.

**SWCTL - Switch Control (0x404)**

Bit Field	Field Name	Type	Default Value	Description
0	FRST	RW	0x0	<b>Fundamental Reset.</b> Writing a one to this bit initiates a Fundamental Reset. Writing a zero has no effect. This field always returns a value of zero when read. Writing of a one to this bit always results in the action specified by this bit to take effect after 1ms. Whitney always returns a completion to the requester before the effect of this bit is applied. See section Fundamental Reset on page 2-3 for the behavior of this bit.
1	HRST	RW	0x0	<b>Hot Reset.</b> Writing a one to this bit initiates a hot reset. Additionally, the upstream port's PHY initiates a full link retrain. Writing a zero has no effect. This field always returns a value of zero when read. Writing of a one to this bit always results in the action specified by this bit to take effect after 1ms. Whitney always returns a completion to the requester before the effect of this bit is applied. See section Hot Reset on page 2-5 for the behavior of this bit.
2	RSTHALT	RW	HWINIT Sticky	<b>Reset Halt.</b> When this bit is set, all of the switch logic except the SMBus interface remains in a reset state. In this state, registers in the device may be initialized by the slave SMBus interface. When this bit is cleared, normal operation ensues. Setting or clearing this bit has no effect following a reset operation. This bit may be set by asserting the RSTHALT signal during a reset operation or through initialization by the serial EEPROM.
3	REGUNLOCK	RW	0x0 Sticky	<b>Register Unlock.</b> When this bit is set, the contents of registers and fields of type Read and Write when Unlocked (RWL) are modified when written to. When this bit is cleared, all registers and fields denoted as RWL become read-only. While the initial value of this field is cleared, it is set during a reset operation, thus allowing serial EEPROM initialization to modify the contents of RWL fields.
4	PWRB-DVUL	RWL	0x0 Sticky	<b>Power Budgeting Data Value Unlock.</b> When this bit is set, the Power Budgeting Data Value [7:0] (PWRBDV[7:0]) registers in all ports may be read and written. When this bit is cleared, then the PWRBDV registers in all ports are read-only.
5	DLDRST	RW	0x0 Sticky	<b>Disable Link Down Hot Reset.</b> When this bit is set, hot resets due to the data link layer of the upstream port transitioning to the DL_Down state are disabled. All other hot reset conditions are unaffected by this bit.
6	DHRSTSEI	RW	0x0 Sticky	<b>Disable Hot Reset Serial EEPROM Initialization.</b> When this bit is set, step 6 "serial EEPROM initialization" is skipped in the hot reset sequence described in section Hot Reset on page 2-5 regardless of the selected switch operating mode.
31:7	Reserved	RO	0x0	Reserved field.

## Notes

## HPCFGCTL - Hot-Plug Configuration Control (0x408)

Bit Field	Field Name	Type	Default Value	Description
0	IPXAPN	RW	0x0 Sticky	<b>Invert Polarity of PxAPN.</b> When this bit is set, the polarity of the PxAPN input is inverted in all ports.
1	IPXPDN	RW	0x0 Sticky	<b>Invert Polarity of PxPDN.</b> When this bit is set, the polarity of the PxPDN input is inverted in all ports.
2	IPXPFN	RW	0x0 Sticky	<b>Invert Polarity of PxPFN.</b> When this bit is set, the polarity of the PxPFN input is inverted in all ports.
3	IPXMRLN	RW	0x0 Sticky	<b>Invert Polarity of PxMRLN.</b> When this bit is set, the polarity of the PxMRLN input is inverted in all ports.
4	IPXAIN	RW	0x0 Sticky	<b>Invert Polarity of PxAIN.</b> When this bit is set, the polarity of the PxAIN output is inverted in all ports.
5	IPXPIN	RW	0x0 Sticky	<b>Invert Polarity of PxPIN.</b> When this bit is set, the polarity of the PxPIN output is inverted in all ports.
6	IPXPEP	RW	0x0 Sticky	<b>Invert Polarity of PxPEP.</b> When this bit is set, the polarity of the PxPEP output is inverted in all ports.
7	IPXLOCKP	RW	0x0 Sticky	<b>Invert Polarity of PxLOCKP.</b> When this bit is set, the polarity of the PxLOCKP output is inverted in all ports.
8	IPXP-WRGDN	RW	0x0 Sticky	<b>Invert Polarity of PxPWRGDN.</b> When this bit is set, the polarity of the PxPWRGDN input is inverted in all ports.
10:9	Reserved	RO	0x0	Reserved field.
11	MRLP-WROFF	RW	0x1 Sticky	<b>MRL Automatic Power Off.</b> When this bit is set and the Manual Retention Latch Present (MRLP) bit is set in the PCI Express Slot Capability (PCIESCAP) register, then power to the slot is automatically turned off when the MRL sensor indicates that the MRL is open. This occurs regardless of the state of the Power Controller Control (PCC) bit in the PCI Express Slot Control (PCIESCTL) register.
12	RMRL-WEMIL	RW	0x0 Sticky	<b>Replace MRL Status with EMIL Status.</b> When this bit is set, the PxMRLN signal inputs are used as electromechanical lock state inputs.
13	TEMICTL	RW	0x0 Sticky	<b>Toggle Electromechanical Interlock Control.</b> When this bit is cleared, the Electromechanical Interlock (PxLOCKP) output is pulsed for at least 100 ms and at most 150 ms when a one is written to the EIC bit in the PCIESCTL register. When this bit is set, writing a one to the EIC register inverts the state of the PxLOCKP output.
15:14	RSTMODE	RW	0x0 Sticky	<b>Reset Mode.</b> This field controls the manner in which downstream port reset outputs are generated. 0x0 - (pec) Power enable controlled reset output 0x1 - (pgc) Power good controlled reset output 0x2 - Reserved 0x3 - Reserved

## Notes

Bit Field	Field Name	Type	Default Value	Description
23:16	PWR2RST	RW	0x14 Sticky	<b>Slot Power to Reset Negation.</b> This field contains the delay from stable downstream port power to negation of the downstream port reset in units of 10 mS. A value of zero corresponds to no delay. This field may be used to meet the $T_{PCPERL}$ specification. The default value corresponds to 200 mS.
31:24	RST2PWR	RW	0x14 Sticky	<b>Reset Negation.</b> This field contains the delay from negation of a downstream port's reset to disabling of a downstream port's power in units of 10 mS. A value of zero corresponds to no delay. The default value corresponds to 200 mS.

**GPIOFUNC - General Purpose I/O Control Function (0x418)**

Bit Field	Field Name	Type	Default Value	Description
15:0	GPIOFUNC	RW	0x0 Sticky	<b>GPIO Function.</b> Each bit in this field controls the corresponding GPIO pin. When set to a one, the corresponding GPIO pin operates as the alternate function as defined in Table 4.1 of Chapter 4. When a bit is cleared to a zero, the corresponding GPIO pin operates as a general purpose I/O pin.
31:16	Reserved	RO	0x0	Reserved field.

**GPIOCFG - General Purpose I/O Configuration (0x41C)**

Bit Field	Field Name	Type	Default Value	Description
15:0	GPIOCFG	RW	0x0 Sticky	<b>GPIO Configuration.</b> Each bit in this field controls the corresponding GPIO pin. When a bit is configured as a general purpose I/O pin and the corresponding bit in this field is set, then the pin is configured as a GPIO output. When a bit is configured as a general purpose I/O pin and the corresponding bit in this field is zero, then the pin is configured as an input. When the pin is configured as an alternate function, the behavior of the pin is defined by the alternate function.
31:16	Reserved	RO	0x0	Reserved field.

**GPIOD - General Purpose I/O Data (0x420)**

Bit Field	Field Name	Type	Default Value	Description
15:0	GPIOD	RW	HWINIT Sticky	<b>GPIO Data.</b> Each bit in this field controls the corresponding GPIO pin. Reading this field returns the current value of each GPIO pin regardless of GPIO pin mode (i.e., alternate function or GPIO pin). Writing a value to this field causes the corresponding pins which are configured as GPIO outputs to change state to the value written.
31:16	Reserved	RO	0x0	Reserved field.

## Notes

**SMBUSSTS - SMBus Status (0x424)**

Bit Field	Field Name	Type	Default Value	Description
0	Reserved	RO	0x0	Reserved field.
7:1	SSMBADDR	RO	HWINIT	<b>Slave SMBus Address.</b> This field contains the SMBus address assigned to the slave SMBus interface.
8	Reserved	RO	0x0	Reserved field.
15:9	MSMBADDR	RO	HWINIT	<b>Master SMBus Address.</b> This field contains the SMBus address assigned to the master SMBus interface.
23:16	Reserved	RO	0x0	Reserved field.
24	EEPROM-DONE	RO	0x0	<b>Serial EEPROM Initialization Done.</b> When the switch is configured to operate in a mode in which serial EEPROM initialization occurs during a Fundamental Reset, this bit is set when serial EEPROM initialization completes or when an error is detected.
25	NAERR	RW1C	0x0	<b>No Acknowledge Error.</b> This bit is set if an unexpected NACK is observed during a master SMBus transaction. The setting of this bit may indicate the following: that the addressed device does not exist on the SMBus (i.e., addressing error); data is unavailable or the device is busy; an invalid command was detected by the slave; or invalid data was detected by the slave.
26	LAERR	RW1C	0x0	<b>Lost Arbitration Error.</b> When the master SMBus interface loses arbitration for the SMBus, it automatically re-arbitrates for the SMBus. If the master SMBus interface loses 16 consecutive arbitration attempts, then the transaction is aborted and this bit is set.
27	OTHER-ERR	RW1C	0x0	<b>Other Error.</b> This bit is set if a misplaced START or STOP condition is detected by the master SMBus interface.
28	ICSERR	RW1C	0x0	<b>Initialization Checksum Error.</b> This bit is set if an invalid checksum is computed during Serial EEPROM initialization or when a configuration done command is not found in the serial EEPROM.
29	URIA	RW1C	0x0	<b>Unmapped Register Initialization Attempt.</b> This bit is set if an attempt is made to initialize via serial EEPROM a register that is not defined in the corresponding PCI configuration space.
31:30	Reserved	RO	0x0	Reserved field.

**SMBUSCTL - SMBus Control (0x428)**

Bit Field	Field Name	Type	Default Value	Description
15:0	MSMBCP	RW	HWINIT Sticky	<b>Master SMBus Clock Prescaler.</b> This field contains a clock prescaler value used during master SMBus transactions. The prescaler clock period is equal to 32 ns multiplied by the value in this field. When the field is cleared to zero or one, the clock is stopped. The initial value of this field is 0x0139 when the master SMBus is configured to operate in slow mode (i.e., 100 KHz) in the boot configuration and to 0x0053 <sup>1</sup> when it is configured to operate in fast mode (i.e., 400 KHz).

## Notes

Bit Field	Field Name	Type	Default Value	Description
16	MSMBIOM	RW	0x0 Sticky	<b>Master SMBus Ignore Other Masters.</b> When this bit is set, the master SMBus proceeds with transactions regardless of whether it won or lost arbitration.
17	ICHECK-SUM	RW	0x0 Sticky	<b>Ignore Checksum Errors.</b> When this bit is set, serial EEPROM initialization checksum errors are ignored (i.e., the checksum always passes).
21:18	Reserved	RO	0x0	Reserved field.
22	SMBDTO	RW	0x0	<b>SMBus Disable Time-out.</b> When this bit is set, SMBus time-outs are disabled on the master and slave SMBuses.
31:23	Reserved	RO	0x0	Reserved field.

<sup>1</sup> The MSMBCLK low minimum pulse width is equal to half the period programmed in this field. The value of 0x53, which corresponds to ~373 KHz, allows the min low pulse width to be satisfied. In systems where this timing parameter is not critical, the operating frequency may be increased.

**EEPROMINTF - Serial EEPROM Interface (0x42C)**

Bit Field	Field Name	Type	Default Value	Description
15:0	ADDR	RW	0x0	<b>EEPROM Address.</b> This field contains the byte address in the Serial EEPROM to be read or written.
23:16	DATA	RW	0x0	<b>EEPROM Data.</b> A write to this field will initiate a serial EEPROM read or write operation, as selected by the OP field, to the address specified in the ADDR field. When a write operation is selected, the value written to this field is the value written to the serial EEPROM. When a read operation is selected, the value written to this field is ignored and the value read from the serial EEPROM may be read from this field when the DONE bit is set.
24	BUSY	RO	0x0	<b>EEPROM Busy.</b> This bit is set when a serial EEPROM read or write operation is in progress. 0x0 -(idle) serial EEPROM interface idle 0x1 -(busy) serial EEPROM interface operation in progress
25	DONE	RW1C	0x0	<b>EEPROM Operation Completed.</b> This bit is set when a serial EEPROM operation has completed. 0x0 -(notdone) interface is idle or operation in progress 0x1 -(done) operation completed
26	OP	RW	0x0	<b>EEPROM Operation Select.</b> This field selects the type of EEPROM operation to be performed when the DATA field is written 0x0 -(write) serial EEPROM write 0x1 -(read) serial EEPROM read
31:27	Reserved	RO	0x0	Reserved field.



## Notes

**IOEXPADDR0 - SMBus I/O Expander Address 0 (0x434)**

Bit Field	Field Name	Type	Default Value	Description
0	Reserved	RO	0x0	Reserved field.
7:1	IOE0ADDR	RWL	0x0 Sticky	<b>I/O Expander 0 Address.</b> This field contains the SMBus address assigned to I/O expander 0 on the master SMBus interface.
16:8	Reserved	RO	0x0	Reserved field.
23:17	IOE2ADDR	RWL	0x0 Sticky	<b>I/O Expander 2 Address.</b> This field contains the SMBus address assigned to I/O expander 2 on the master SMBus interface.
31:24	Reserved	RO	0x0	Reserved field.

**IOEXPADDR1 - SMBus I/O Expander Address 1 (0x438)**

Bit Field	Field Name	Type	Default Value	Description
0	Reserved	RO	0x0	Reserved field.
7:1	IOE4ADDR	RWL	0x0 Sticky	<b>I/O Expander 4 Address.</b> This field contains the SMBus address assigned to I/O expander 4 on the master SMBus interface.
31:8	Reserved	RO	0x0	Reserved field.

**GPECTL - General Purpose Event Control (0x450)**

Bit Field	Field Name	Type	Default Value	Description
0	IGPE	RW	0x0 Sticky	<b>Invert General Purpose Event Enable Signal Polarity.</b> When this bit is set, the polarity of all General Purpose Event (GPEN) signals is inverted. 0x0 -(normal) GPEN signals are active low 0x1 -(invert) GPEN signals are active high
1	Reserved	RO	0x0	Reserved field.
2	P2GPEE	RW	0x0 Sticky	<b>Port 2 General Purpose Event Enable.</b> When this bit is set, the hot-plug INTx, MSI and PME event notification mechanisms defined by the PCIe base 2.0 specification are disabled for port 2 and are instead signalled through General Purpose Event (GPEN) signal assertions. GPEN is an alternate function of GPIO[7].
3	Reserved	RO	0x0	Reserved field.
4	P4GPEE	RW	0x0 Sticky	<b>Port 4 General Purpose Event Enable.</b> When this bit is set, the hot-plug INTx, MSI and PME event notification mechanisms defined by the PCIe base 2.0 specification are disabled for port 4 and are instead signalled through General Purpose Event (GPEN) signal assertions. GPEN is an alternate function of GPIO[7].
5	Reserved	RO	0x0	Reserved field.

## Notes

Bit Field	Field Name	Type	Default Value	Description
6	P6GPEE	RW	0x0 Sticky	<b>Port 6 General Purpose Event Enable.</b> When this bit is set, the hot-plug INTx, MSI and PME event notification mechanisms defined by the PCIe base 2.0 specification are disabled for port 6 and are instead signalled through General Purpose Event (GPEN) signal assertions. GPEN is an alternate function of GPIO[7].
31:7	Reserved	RO	0x0	Reserved field.

**GPESTS - General Purpose Event Status (0x454)**

Bit Field	Field Name	Type	Default Value	Description
1:0	Reserved	RO	0x0	Reserved field.
2	P2GPES	RO	0x0	<b>Port 2 General Purpose Event Status.</b> When this bit is set, the corresponding port is signalling a general purpose event by asserting the GPEN signal. This bit is never set if the corresponding general purpose event is not enabled in the GPECTL register. GPEN is an alternate function of GPIO[7] and GPIO[7] is asserted only if enabled to operate as an alternate function.
3	Reserved	RO	0x0	Reserved field.
4	P4GPES	RO	0x0	<b>Port 4 General Purpose Event Status.</b> When this bit is set, the corresponding port is signalling a general purpose event by asserting the GPEN signal. This bit is never set if the corresponding general purpose event is not enabled in the GPECTL register. GPEN is an alternate function of GPIO[7] and GPIO[7] is asserted only if enabled to operate as an alternate function.
5	Reserved	RO	0x0	Reserved field.
6	P6GPES	RO	0x0	<b>Port 6 General Purpose Event Status.</b> When this bit is set, the corresponding port is signalling a general purpose event by asserting the GPEN signal. This bit is never set if the corresponding general purpose event is not enabled in the GPECTL register. GPEN is an alternate function of GPIO[7] and GPIO[7] is asserted only if enabled to operate as an alternate function.
31:7	Reserved	RO	0x0	Reserved field.

## Physical Layer Control and Status Registers

**SERDESCTL- SerDes Control (0x500)**

Bit Field	Field Name	Type	Default Value	Description
7:0	Reserved	RO	0x0	Reserved field.

## Notes

Bit Field	Field Name	Type	Default Value	Description
8	LSE	RW	0x0 Sticky	Low-Swing Mode Enable. When set, this bit enables Low-Swing mode operation at the SerDes Transmit logic. Refer to section Low-Swing Transmitter Voltage Mode on page 3-9 for further details. 0x0 - Full-Swing Mode 0x1 - Low-Swing Mode
31:9	Reserved	RO	0x0	Reserved field.

**PHYLSTATE0 - Phy Link State 0 (0x534)**

Bit Field	Field Name	Type	Default Value	Description
30:0	Reserved	RO	0x0	Reserved field.
31	FLRET	RW	0x0	<b>Full Link Retrain.</b> Writing a one to this field initiates full link retraining by directing the PHY LTSSM into the DETECT state. This bit always returns zero when read. For the upstream port, writing of a one to this bit always results in the action specified by this bit to take effect after 1ms. Whitney always returns a completion to the requester before the effect of this bit is applied.

## Power Management Control and Status Registers

**PMETOATIMER - PME\_TO\_Ack Timer (0x708)**

Bit Field	Field Name	Type	Default Value	Description
7:0	PMETOATO	RW	0x0A Sticky	<b>PME_TO_Ack Time-Out.</b> This field contains the amount of time a PES16T4G2 downstream port will wait for a PME_TO_Ack message. If a PME_TO_Ack message is not received within this time-out period, the downstream port will stop waiting for a PME_TO_Ack message and proceed to put the link into L2/L3 Ready. The value in this field is in units of milliseconds. The default value corresponds to a time-out of 10 ms. A value of zero in this field corresponds to an immediate time-out. A value of 0xFF in this field corresponds to no time limit (i.e., wait forever).
31	Reserved	RO	0x0	Reserved field.

Notes



# JTAG Boundary Scan

## Notes

### Introduction

The JTAG Boundary Scan interface provides a way to test the interconnections between integrated circuit pins after they have been assembled onto a circuit board.

There are two pin types present in the PES16T4G2: AC-coupled and DC-coupled (also called AC and DC pins). The Boundary Scan interface in the PES16T4G2 is IEEE 1149.1 compliant to allow testing of the DC pins. The DC pins are those “normal” pins that do not require AC-coupling.

The presence of AC-coupling capacitors on some of the PES16T4G2 pins prevents DC values from being driven between a driver and receiver. An AC Boundary Scan methodology, as described in IEEE 1149.6, is available to provide a time-varying signal to pass through the AC-coupling when in AC test mode; however, IEEE 1149.6 is not supported in the PES16T4G2.

### Test Access Point

The system logic utilizes a 16-state, TAP controller, a six-bit instruction register, and five dedicated pins to perform a variety of functions. The primary use of the JTAG TAP Controller state machine is to allow the five external JTAG control pins to control and access the PES16T4G2's many external signal pins. The JTAG TAP Controller can also be used for identifying the device part number. The JTAG logic of the PES16T4G2 is depicted in Figure 9.1.

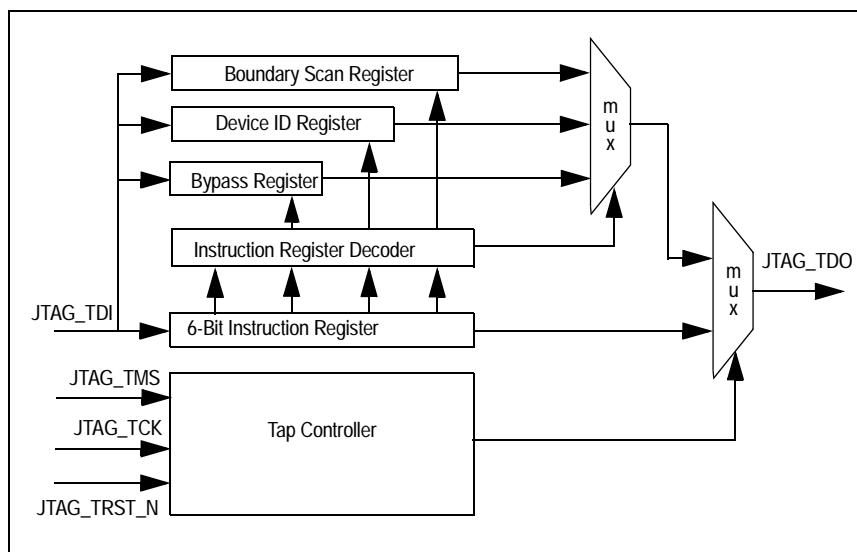

Figure 9.1 Diagram of the JTAG Logic

Refer to the IEEE 1149.1 document for an operational description of the Boundary Scan and TAP controller.

### Signal Definitions

JTAG operations such as reset, state-transition control, and clock sampling are handled through the signals listed in Table 9.1. A functional overview of the TAP Controller and Boundary Scan registers is provided in the sections following the table.

Notes

Pin Name	Type	Description
JTAG_TRST_N	Input	JTAG RESET (active low) Asynchronous reset for JTAG TAP controller (internal pull-up)
JTAG_TCK	Input	JTAG Clock Test logic clock. JTAG_TMS and JTAG_TDI are sampled on the rising edge. JTAG_TDO is output on the falling edge.
JTAG_TMS	Input	JTAG Mode Select. Requires an external pull-up. Controls the state transitions for the TAP controller state machine (internal pull-up)
JTAG_TDI	Input	JTAG Input Serial data input for BSC chain, Instruction Register, IDCODE register, and BYPASS register (internal pull-up)
JTAG_TDO	Output	JTAG Output Serial data out. Tri-stated except when shifting while in Shift-DR and SHIFT-IR TAP controller states.

Table 9.1 JTAG Pin Descriptions

The TAP controller transitions from state to state, according to the value present on JTAG\_TMS, as sampled on the rising edge of JTAG\_TCK. The Test-Logic Reset state can be reached either by asserting JTAG\_TRST\_N or by applying a 1 to JTAG\_TMS for five consecutive cycles of JTAG\_TCK. A state diagram for the TAP controller appears in Figure 9.2. The value next to state represent the value that must be applied to JTAG\_TMS on the next rising edge of JTAG\_TCK, to transition in the direction of the associated arrow.

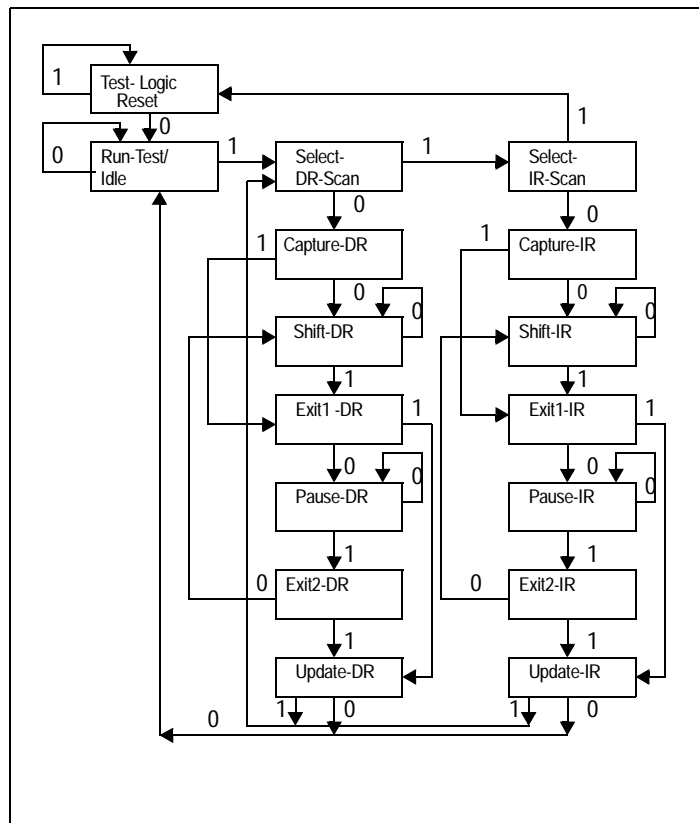

Figure 9.2 State Diagram of PES16T4G2's TAP Controller

## Notes

## Boundary Scan Chain

Function	Pin Name	Type <sup>1</sup>	Boundary Cell <sup>2</sup>
PCI Express Interface	PE0RN[3:0]	I	O
	PE0RP[3:0]	I	O
	PE0TN[3:0]	O	C
	PE0TP[3:0]	O	
	PE2RN[3:0]	I	O
	PE2RP[3:0]	I	O
	PE2TN[3:0]	O	C
	PE2TP[3:0]	O	
	PE4RN[3:0]	I	O
	PE4RP[3:0]	I	O
	PE4TN[3:0]	O	C
	PE4TP[3:0]	O	
	PE6RN[3:0]	I	O
	PE6RP[3:0]	I	O
	PE6TN[3:0]	O	C
	PE6TP[3:0]	O	
	PEREFCLKN[0]	I	—
	PEREFCLKP[0]	I	—
	REFCLKM	I	O
SMBus	MSMBADDR[4:1]	I	O
	MSMBCLK	I/O	O/C
	MSMBDAT	I/O	O/C
	SSMBADDR[5,3:1]	I	O
	SSMBCLK	I/O	O/C
	SSMBDAT	I/O	O/C
General Purpose I/O	GPIO[15:0]	I/O	O/C
System Pins	CCLKDS	I	O
	CCLKUS	I	O
	MSMBSMODE	I	O
	PERSTN	I	O
	RSTHALT	I	O
	SWMODE[2:0]	I	—
EJTAG / JTAG	JTAG_TCK	I	—
	JTAG_TDI	I	—
	JTAG_TDO	O	—
	JTAG_TMS	I	—
	JTAG_TRST_N	I	—

Table 9.2 Boundary Scan Chain

<sup>1</sup> I = Input, O = Output<sup>2</sup> O = Observe, C = Control

## Notes

## Test Data Register (DR)

The Test Data register contains the following:

- ◆ Bypass register
- ◆ Boundary Scan registers
- ◆ Device ID register

These registers are connected in parallel between a common serial input and a common serial data output and are described in the following sections. For more detailed descriptions, refer to IEEE Standard Test Access Port (IEEE Std. 1149.1).

## Boundary Scan Registers

This boundary scan chain is connected between JTAG\_TDI and JTAG\_TDO when EXTEST or SAMPLE/PRELOAD instructions are selected. Once EXTEST is selected and the TAP controller passes through the UPDATE-IR state, whatever value that is currently held in the boundary scan register's output latches is immediately transferred to the corresponding outputs or output enables.

Therefore, the SAMPLE/PRELOAD instruction must first be used to load suitable values into the boundary scan cells, so that inappropriate values are not driven out onto the system pins. All of the boundary scan cells feature a negative edge latch, which guarantees that clock skew cannot cause incorrect data to be latched into a cell. The input cells are sample-only cells. The simplified logic configuration is shown in Figure 9.3.

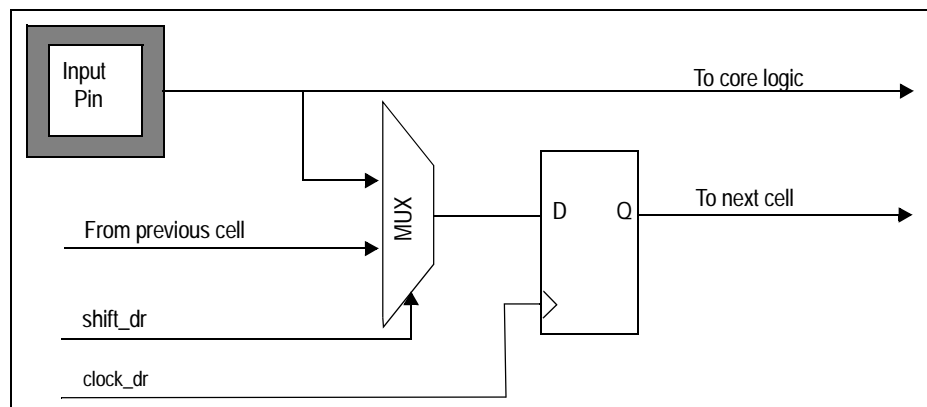

Figure 9.3 Diagram of Observe-only Input Cell

The simplified logic configuration of the output cells is shown in Figure 9.4.



Notes

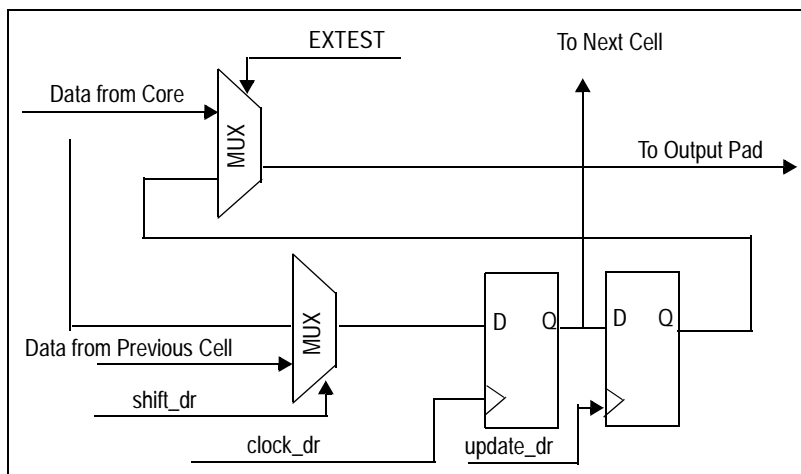

Figure 9.4 Diagram of Output Cell

The output enable cells are also output cells. The simplified logic is shown in Figure 9.5.

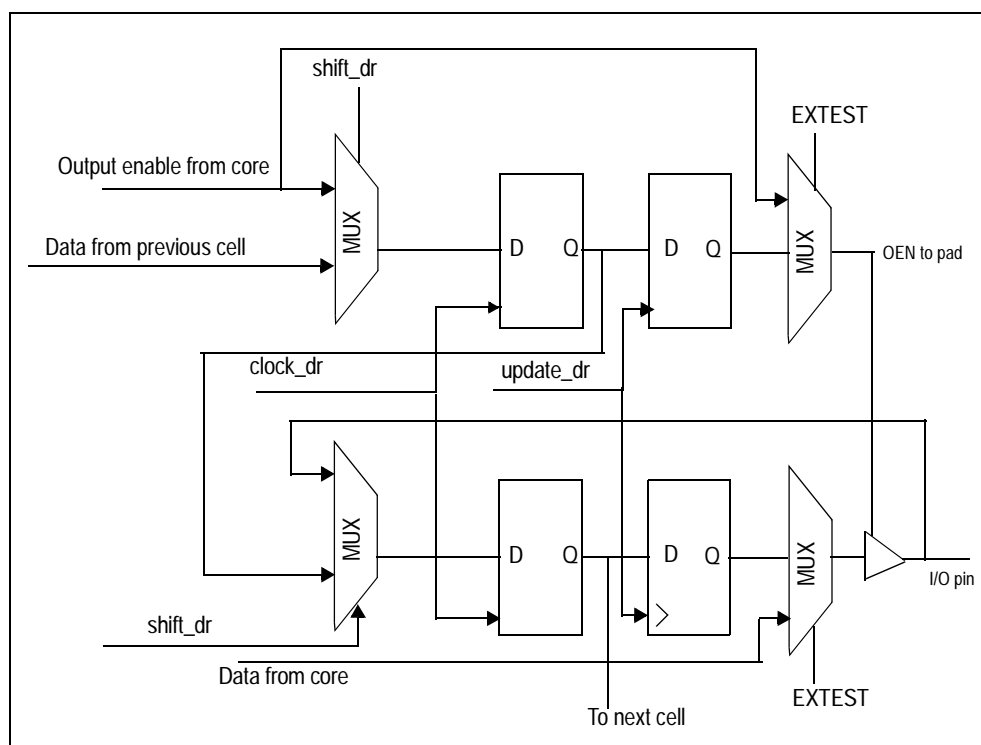

Figure 9.5 Diagram of Bidirectional Cell

The bidirectional cells are composed of only two boundary scan cells. They contain one output enable cell and one capture cell, which contains only one register. The input to this single register is selected via a mux that is selected by the output enable cell when EXTEST is disabled. When the Output Enable Cell is driving a high out to the pad (which enables the pad for output) and EXTEST is disabled, the Capture Cell will be configured to capture output data from the core to the pad.

However, in the case where the Output Enable Cell is low (signifying a tri-state condition at the pad) or EXTEST is enabled, the Capture Cell will capture input data from the pad to the core. The configuration is shown graphically in Figure 9.5.

## Notes

## Instruction Register (IR)

The Instruction register allows an instruction to be shifted serially into the device at the rising edge of JTAG\_TCK. The instruction is then used to select the test to be performed or the test register to be accessed, or both. The instruction shifted into the register is latched at the completion of the shifting process, when the TAP controller is at the Update-IR state.

The Instruction register contains six shift-register-based cells that can hold instruction data. This register is decoded to perform the following functions:

- To select test data registers that may operate while the instruction is current. The other test data registers should not interfere with chip operation and selected data registers.
- To define the serial test data register path used to shift data between JTAG\_TDI and JTAG\_TDO during data register scanning.

The Instruction register is comprised of 6 bits to decode instructions, as shown in Table 9.3.

Instruction	Definition	Opcode
EXTEST	Mandatory instruction allowing the testing of board level interconnections. Data is typically loaded onto the latched parallel outputs of the boundary scan shift register using the SAMPLE/PRELOAD instruction prior to use of the EXTEST instruction. EXTEST will then hold these values on the outputs while being executed. Also see the CLAMP instruction for similar capability.	000000
SAMPLE/ PRELOAD	Mandatory instruction that allows data values to be loaded onto the latched parallel output of the boundary scan shift register prior to selection of the other boundary scan test instruction. The Sample instruction allows a snapshot of data flowing from the system pins to the on-chip logic or vice versa.	000001
IDCODE	Provided to select Device Identification to read out manufacturer's identity, part, and version number.	000010
HIGHZ	Tri-states all output and bidirectional boundary scan cells.	000011
RESERVED		000100 — 101100
VALIDATE	Automatically loaded into the instruction register whenever the TAP controller passes through the CAPTURE-IR state. The lower two bits '01' are mandated by the IEEE Std. 1149.1 specification.	101101
RESERVED		101110 — 111101
CLAMP	Provides JTAG users with the option to bypass the part's JTAG controller while keeping the part outputs controlled similar to EXTEST.	111110
BYPASS	The BYPASS instruction is used to truncate the boundary scan register as a single bit in length.	111111

Table 9.3 Instructions Supported by PES16T4G2's JTAG Boundary Scan

## EXTEST

The external test (EXTEST) instruction is used to control the boundary scan register, once it has been initialized using the SAMPLE/PRELOAD instruction. Using EXTEST, the user can then sample inputs from or load values onto the external pins of the PES16T4G2. Once this instruction is selected, the user then uses the SHIFT-DR TAP controller state to shift values into the boundary scan chain. When the TAP controller passes through the UPDATE-DR state, these values will be latched onto the output pins or into the output enables.

## Notes

## SAMPLE/PRELOAD

The sample/preload instruction has a dual use. The primary use of this instruction is for preloading the boundary scan register prior to enabling the EXTEST instruction. Failure to preload will result in unknown random data being driven onto the output pins when EXTEST is selected. The secondary function of SAMPLE/PRELOAD is for sampling the system state at a particular moment. Using the SAMPLE function, the user can halt the device at a certain state and shift out the status of all of the pins and output enables at that time.

## BYPASS

The BYPASS instruction is used to truncate the boundary scan register to a single bit in length. During system level use of the JTAG, the boundary scan chains of all the devices on the board are connected in series. In order to facilitate rapid testing of a given device, all other devices are put into BYPASS mode. Therefore, instead of having to shift many times to get a value through the PES16T4G2, the user only needs to shift one time to get the value from JTAG\_TDI to JTAG\_TDO. When the TAP controller passes through the CAPTURE-DR state, the value in the BYPASS register is updated to be 0.

## CLAMP

This instruction, listed as optional in the IEEE 1149.1 JTAG Specifications, allows the boundary scan chain outputs to be clamped to fixed values. When the clamp instruction is issued, the bypass register is selected between TDI and TDO and the scan chain passes through this register to devices further downstream.

## IDCODE

The IDCODE instruction is automatically loaded when the TAP controller state machine is reset either by the use of the JTAG\_TRST\_N signal or by the application of a '1' on JTAG\_TMS for five or more cycles of JTAG\_TCK as per the IEEE Std. 1149.1 specification. The least significant bit of this value must always be 1. Therefore, if a device has a Device ID register, it will shift out a 1 on the first shift if it is brought directly to the SHIFT-DR TAP controller state after the TAP controller is reset. The board-level tester can then examine this bit and determine if the device contains a Device ID register (the first bit is a 1), or if the device only contains a BYPASS register (the first bit is 0).

However, even if the device contains a Device ID register, it must also contain a BYPASS register. The only difference is that the BYPASS register will not be the default register selected during the TAP controller reset. When the IDCODE instruction is active and the TAP controller is in the Shift-DR state, the thirty-two bit value that will be shifted out of the Device ID register is shown in Figure 9.6.

Bit(s)	Mnemonic	Description	R/W	Reset
0	Reserved	Reserved	R	0x1
11:1	Manuf_ID	<b>Manufacturer Identity</b> (11 bits) This field identifies the manufacturer as IDT.	R	0x33
27:12	Part_number	<b>Part Number</b> (16 bits) This field identifies the silicon as PES16T4G2.	R	0x8060
31:28	Version	<b>Version</b> (4 bits) This field identifies the silicon revision of the PES16T4G2.	R	silicon-dependent

Table 9.4 System Controller Device Identification Register

Version	Part Number	Mnfg. ID	LSB
xxxx	1000 0000 0110 0000	0000 0011 011	1

Figure 9.6 Device ID Register Format

## Notes

### VALIDATE

The VALIDATE instruction is automatically loaded into the instruction register whenever the TAP controller passes through the CAPTURE-IR state. The lower two bits '01' are mandated by the IEEE Std. 1149.1 specification.

### RESERVED

Reserved instructions implement various test modes used in the device manufacturing process. The user should not enable these instructions.

### Usage Considerations

As previously stated, there are internal pull-ups on JTAG\_TRST\_N, JTAG\_TMS, and JTAG\_TDI. However, JTAG\_TCK also needs to be driven to a known value. It is best to either drive a zero on the JTAG\_TCK pin when it is not being used or to use an external pull-down resistor. In order to guarantee that the JTAG does not interfere with normal system operation, the TAP controller should be forced into the Test-Logic-Reset controller state by continuously holding JTAG\_TRST\_N low and/or JTAG\_TMS high when the chip is in normal operation. If JTAG will not be used, externally pull-down JTAG\_TRST\_N low to disable it.