

NOTES:

1. ALL DIMENSIONS AND TOLERANCES ARE PER ASME Y14.5M-1994.
2. ALL DIMENSIONS ARE IN MILLIMETERS.
3. SEATING PLANE AND PRIMARY DATUM -C- ARE DEFINED BY THE CONTACT POINTS OF THREE OR MORE SOLDER BALLS THAT SUPPORT THE DEVICE WHEN PLACED ON A TOP OF A PLANAR SURFACE.
4. THE BUMP ARRAY IS OFFSET 0.090MM FROM THE DIE CENTER IN THE Y DIRECTION TOWARDS A1 PIN INDICATOR.

REVISIONS			
REV	DESCRIPTION	DATE	APPROVED
00	INITIAL RELEASE	11/16/15	JH
01	MODIFY BUMP HEIGHT & DIAMETER.	12/07/15	JH

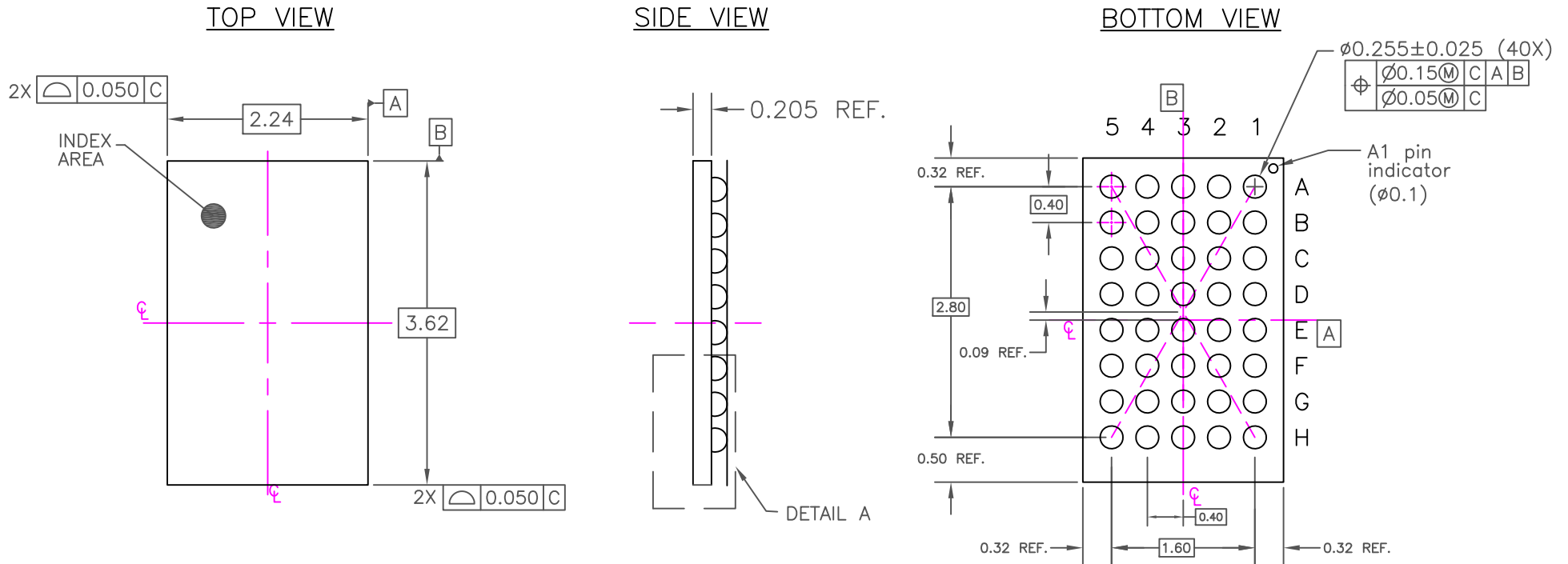

DETAIL A
(ROTATED 90 DEG CW)

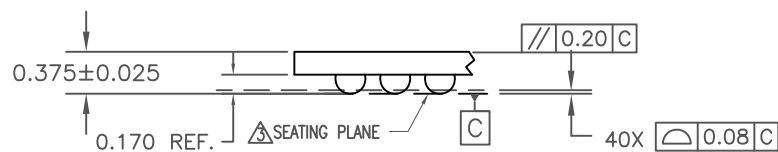

TOLERANCES UNLESS SPECIFIED DECIMAL XX± 0.05 ANGULAR ± XXX± 0.012 XXXX±		 www.IDT.com	6024 SILVER CREEK VALLEY ROAD, SAN JOSE, CA 95138 PHONE: (408) 284-8200 FAX: (408) 284-3572	
APPROVALS	DATE		TITLE	
DRAWN RAC	11/16/15	AWU40 PACKAGE OUTLINE 2.24 x 3.62 mm BODY 0.4mm PITCH DSBGA		
CHECKED		SIZE	DRAWING No.	REV
		C	PSC-4626	01
DO NOT SCALE DRAWING			SHEET 1 OF 2	

REVISIONS			
REV	DESCRIPTION	DATE	APPROVED
00	INITIAL RELEASE	11/16/15	JH
01	MODIFY BUMP HEIGHT & DIAMETER.	12/07/15	JH

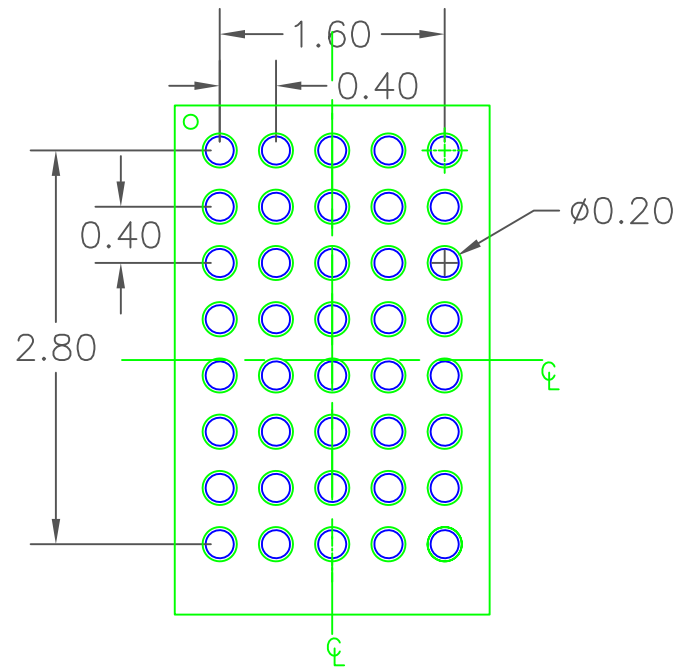

RECOMMENDED LAND PATTERN

NOTES:

1. ALL DIMENSIONS ARE IN MM. ANGLES IN DEGREES.
2. TOP DOWN VIEW, AS VIEWED ON PCB.
3. COMPONENT OUTLINE SHOWS FOR REFERENCE IN GREEN.
4. LAND PATTERN IN BLUE. NSMD PATTERN ASSUMED.
5. LAND PATTERN RECOMMENDATION PER IDT WLCSP APPLICATION NOTE.

TOLERANCES UNLESS SPECIFIED		 IDT™ 6024 SILVER CREEK VALLEY ROAD, SAN JOSE, CA 95138 PHONE: (408) 284-8200 FAX: (408) 284-3572 www.IDT.com	
DECIMAL	ANGULAR		
XX± 0.05	±	TITLE AWU40 PACKAGE OUTLINE 2.24 x 3.62 mm BODY 0.4mm PITCH DSBGA	
XXX± 0.012		APPROVALS DRAWN RAC CHECKED	DATE 11/16/15
XXXX±		SIZE C	DRAWING No. PSC-4626
		DO NOT SCALE DRAWING	REV 01
		SHEET 2 OF 2	