

REVISIONS			
REV	DESCRIPTION	DATE	APPROVED
00	INITIAL RELEASE	01/16/04	TU VU
01	COMBINE POD & LAND PATTERN	05/14/13	RC
02	UPDATE TO REVISION 2 IN DCP	12/5/14	RC

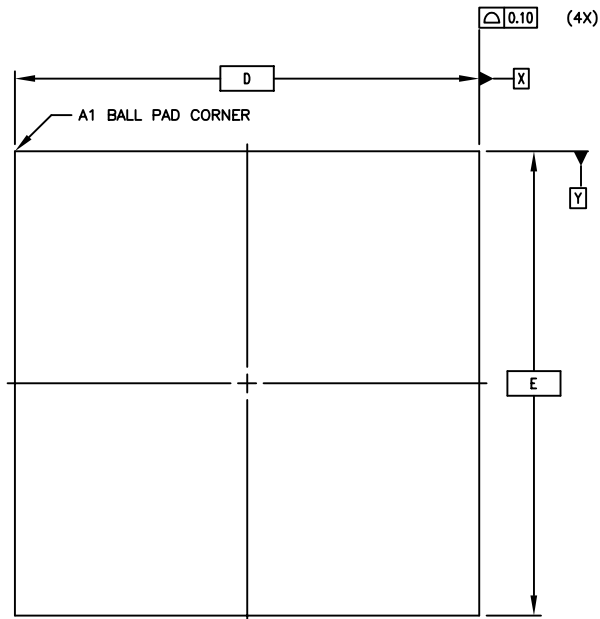

TOP VIEW

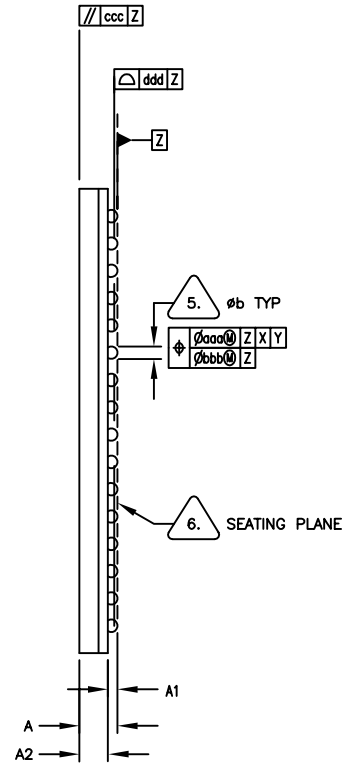

SIDE VIEW

SYMBOL	JEDEC VARIATION			NOTE
	AAF-1			
	MIN	NOM	MAX	
A	1.66	1.76	1.86	
A1	.31	.36	.41	
D	17.00 BSC			
D1	15.00 BSC			
E	17.00 BSC			
E1	15.00 BSC			
MD	16			3
ME	16			3
N	256			4
e	1.00 BSC			
b	.41	.46	.51	5
aaa	-	-	.15	
bbb	-	-	.08	
ccc	-	-	.10	
ddd	-	-	.12	

UNLESS OTHERWISE SPECIFIED  
DIMENSIONS ARE IN MILLIMETERS  
DECIMAL                    ANGULAR  
XX ±0.10                    ±1°  
XXX ±0.05  
XXX ±0.03



6024 SILVER CREEK VALLEY ROAD  
San Jose, CA 95138  
PHONE: (408) 284-8200  
FAX: (408) 284-2775

APPROVALS  
DRAWN *BP*  
CHECKED

DATE

12/15/13

BP/BPG256 PACKAGE OUTLINE  
17.0 x 17.0 mm BODY CABGA

DRAWING No.  
PSC-4126

SIZE  
C

SCALE  
N/A

REV  
02

DO NOT SCALE DRAWING

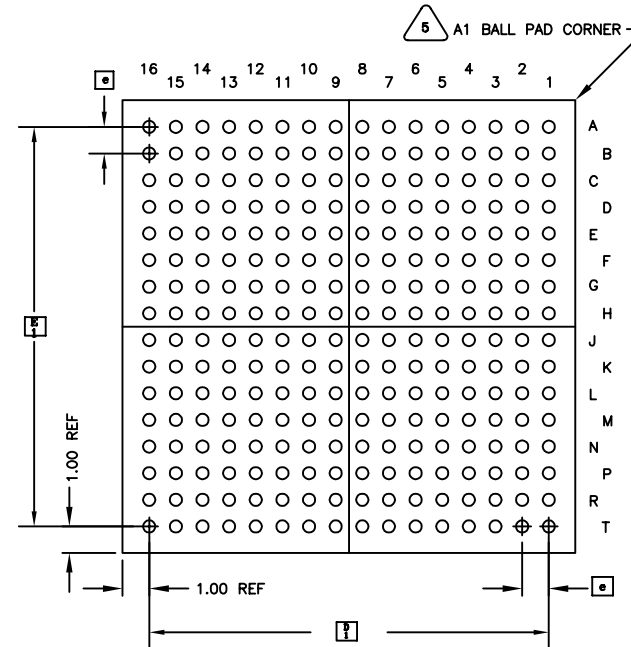
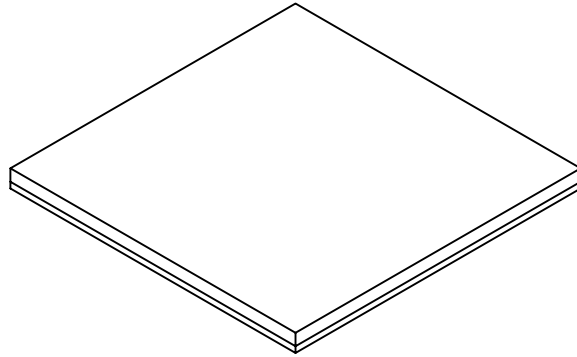

SHEET 1 OF 3

REVISIONS			
REV	DESCRIPTION	DATE	APPROVED
00	INITIAL RELEASE	01/16/04	TU VU
01	COMBINE POD & LAND PATTERN	5/14/13	RC
02	UPDATE TO REVISION 2 IN DCP	12/5/14	RC



BOTTOM VIEW  
256 SOLDER BALLS

NOTES: UNLESS OTHERWISE SPECIFIED

- ALL DIMENSIONS AND TOLERANCES CONFORM TO ASME Y14.5M-1994.
- "e" REPRESENTS THE BASIC SOLDER BALL GRID PITCH.
- "MD" IS THE MAXIMUM SOLDER BALL MATRIX SIZE IN THE "D" DIRECTION.  
"ME" IS THE MAXIMUM SOLDER BALL MATRIX SIZE IN THE "E" DIRECTION.  
"N" IS THE MAXIMUM ALLOWABLE NUMBER OF SOLDER BALLS.
-  DIMENSION "b" IS MEASURED AT THE MAXIMUM SOLDER BALL DIAMETER, PARALLEL TO PRIMARY DATUM Z.
-  PRIMARY DATUM Z AND SEATING PLANE ARE DEFINED BY THE SPHERICAL CROWNS OF THE SOLDER BALLS.
- "A1" ID CORNER MUST BE IDENTIFIED. IDENTIFICATION MAY BE BY MEANS OF CHAMFER, METALLIZED OR INK MARK, INDENTATION OR OTHER FEATURE OF THE PACKAGE BODY.
- ALL DIMENSIONS ARE IN MILLIMETERS.
- THIS DRAWING CONFORMS TO JEDEC PUBLICATION 95 REGISTRATION MO-192 VARIATION DAF-1

UNLESS OTHERWISE SPECIFIED DIMENSIONS ARE IN MILLIMETERS		 <b>IDT.</b> 6024 SILVER CREEK VALLEY ROAD San Jose, CA 95138 PHONE: (408) 284-8200 FAX: (408) 284-2775 www.IDT.com		
DECIMAL	ANGULAR			
XX ±0.10	±1°			
XX ±0.05				
XXX ±0.03				
APPROVALS	DATE	BP/BPG256 PACKAGE OUTLINE 17.0 x 17.0 mm BODY CABGA		
DRAWN <i>BP</i>	12/15/03			
CHECKED				
DRAWING No.		SIZE	SCALE	REV
PSC-4126		C	N/A	02
DO NOT SCALE DRAWING				SHEET 2 OF 3

REVISIONS			
REV	DESCRIPTION	DATE	APPROVED
00	INITIAL RELEASE	01/16/04	TU VU
01	COMBINE POD & LAND PATTERN	05/14/13	RC
02	UPDATE TO REVISION 2 IN DCP	12/5/14	RC

"A1" ID CORNER

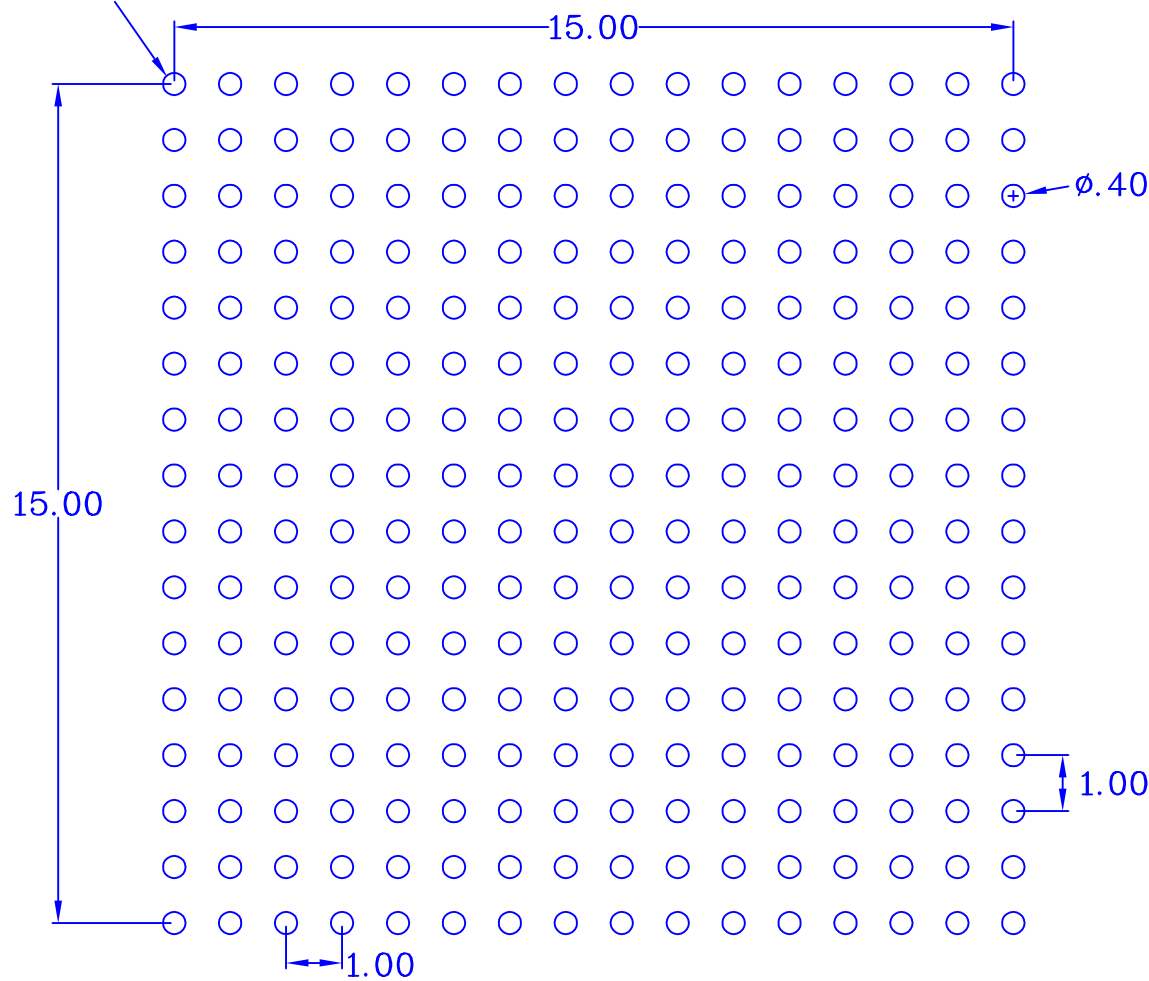

RECOMMENDED LAND PATTERN DIMENSION (mm)

UNLESS OTHERWISE SPECIFIED DIMENSIONS ARE IN MILLIMETERS		IDT 6024 SILVER CREEK VALLEY ROAD San Jose, CA 95138 www.IDT.com		
DECIMAL	ANGULAR	PHONE: (408) 284-8200 FAX: (408) 284-2775		
XX ±0.10	±1°	BP/BPG256 PACKAGE OUTLINE 17.0 x 17.0 mm BODY CABGA		
XXX ±0.05				
XXXX ±0.03				
APPROVALS	DATE	DRAWING No. PSC-4126		
DRAWN <i>BP</i>	12/15/03			
CHECKED				
		SIZE	SCALE	REV
		C	N/A	02
DO NOT SCALE DRAWING			SHEET 3 OF 3	