

DATE CREATED		REVISIONS		
		REV	DESCRIPTION	AUTHOR
11/15/17		00	INITIAL RELEASE	JH

NOTE: REFER TO DCP FOR OFFICIAL RELEASE DATE

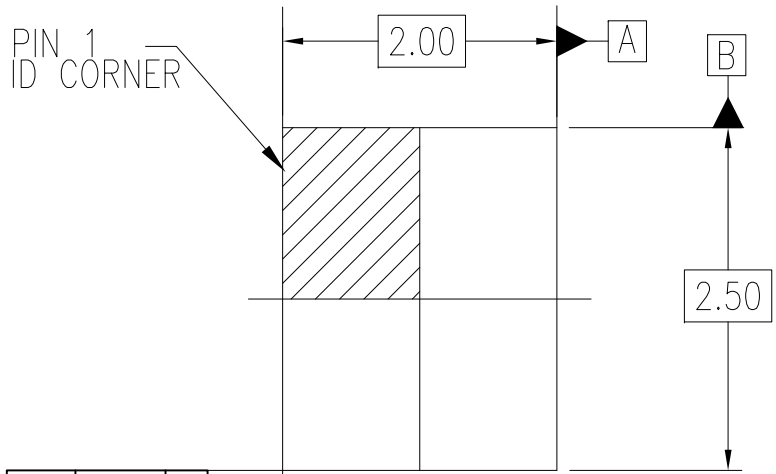

$\text{R}0.10 \text{ C} \ 2\text{X}$

$\text{R}0.10 \text{ C} \ 2\text{X}$

TOP VIEW

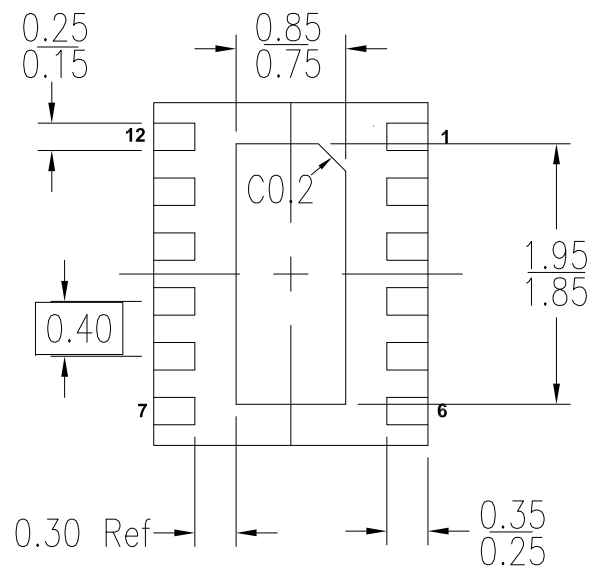

0.30 Ref

BOTTOM VIEW

$\text{R}0.10 \text{ C}$

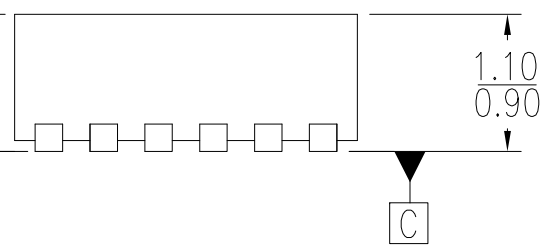

$\text{R}0.08 \text{ C}$

SIDE VIEW (ROTATE 90 Deg.)

NOTE:

1. DIMENSIONING AND TOLERANCING CONFORM TO ASME Y14.5-2009.
2. ALL DIMENSIONS ARE IN MILLIMETERS.

TOLERANCES UNLESS SPECIFIED		 <b>IDT™</b> www.IDT.com	6024 Silver Creek Valley Road San Jose CA 95138 PHONE: (408) 284-8200 FAX: (408) 284-3572	
DECIMAL	ANGULAR			
X± .1	±1°			
XX± .05				
XXX± .030				
TITLE		NJG12 Package Outline Drawing 2.00 x 2.50 x 1.00 mm Body Epad 0.80 x 1.90 mm. 0.40mm Pitch DFN		
SIZE	DRAWING No.	REV		
C	PSC-4736	00		
DO NOT SCALE DRAWING		SHEET 1 OF 2		

DATE CREATED		REVISIONS		AUTHOR
DATE	REV	DESCRIPTION		
11/15/17	00	INITIAL RELEASE		JH
NOTE: REFER TO DCP FOR OFFICIAL RELEASE DATE				

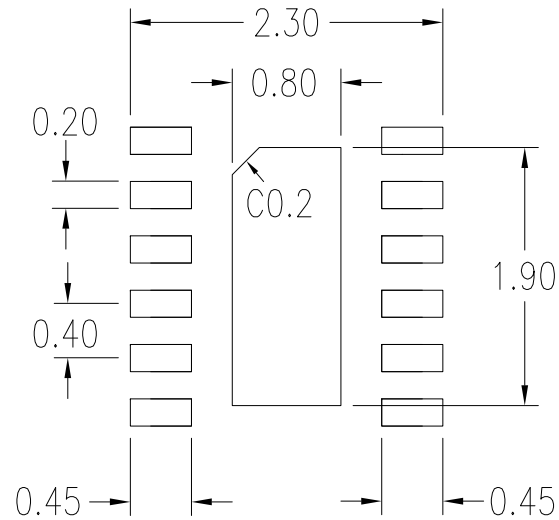

RECOMMENDED LAND PATTERN

NOTES:

1. ALL DIMENSIONS ARE IN mm. ANGLES IN DEGREES.
2. TOP DOWN VIEW. AS VIEWED ON PCB.
3. LAND PATTERN RECOMMENDATION PER IPC-7351B GENERIC REQUIREMENT FOR SURFACE MOUNT DESIGN AND LAND PATTERN.

TOLERANCES UNLESS SPECIFIED		 <b>IDT™</b> www.IDT.com	6024 Silver Creek Valley Road San Jose CA 95138 PHONE: (408) 284-8200 FAX: (408) 284-3572	
DECIMAL	ANGULAR			
X± .1	±1°			
XX± .05				
XXX± .030				
		TITLE NJG12 Package Outline Drawing 2.00 x 2.50 x 1.00 mm Body Epad 0.80 x 1.90 mm. 0.40mm Pitch DFN		
SIZE	DRAWING No.	REV		
C	PSC-4736	00		
DO NOT SCALE DRAWING			SHEET 2 OF 2	