

| REVISIONS | | | |
|-----------|--|---------|----------|
| REV | DESCRIPTION | DATE | APPROVED |
| 00 | INITIAL RELEASE | 5/3/12 | M. ROY |
| 01 | CHANGE PCD & LAND PATTERN CHANGE PACKAGE THICKNESS | 5/13/13 | RC |

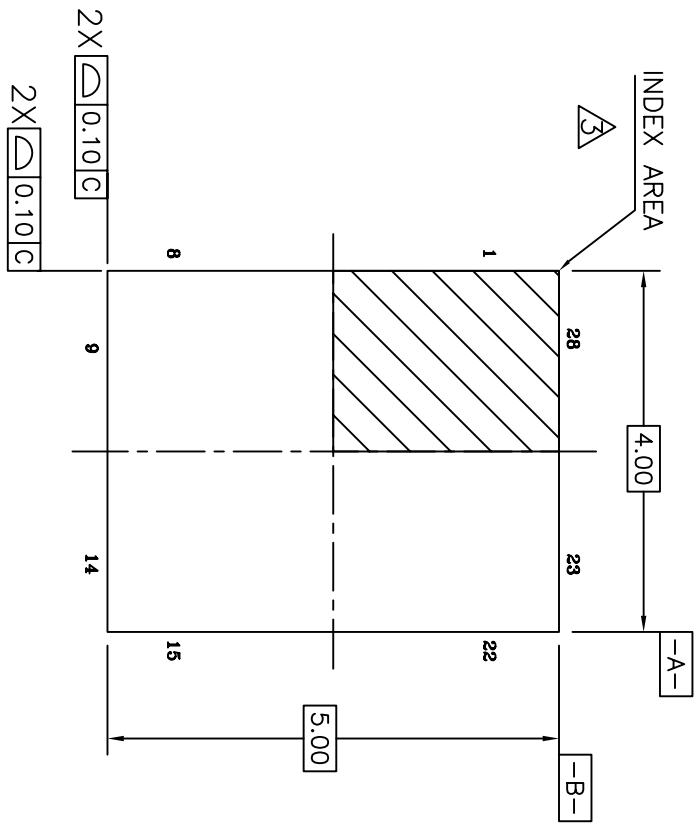

TOP VIEW

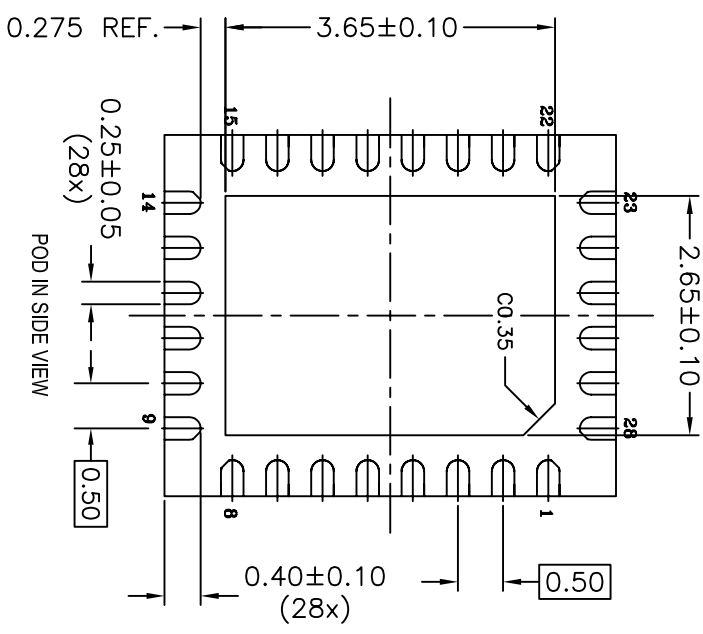

BOTTOM VIEW

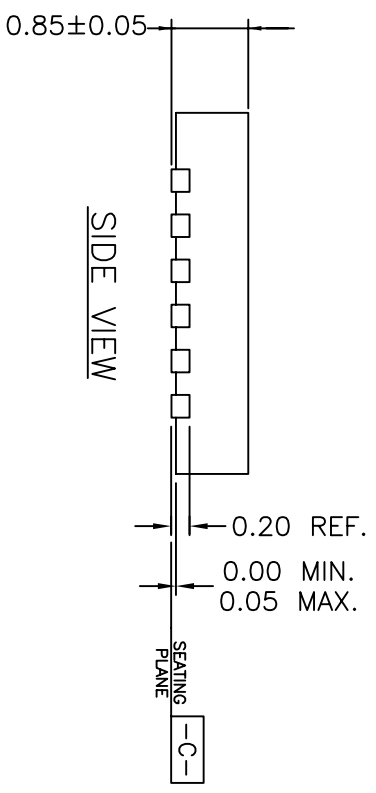

SIDE VIEW

- NOTES:
1. ALL DIMENSIONING AND TOLERANCING CONFORM TO ANSI Y14.5M-1982
 2. ALL DIMENSIONS ARE IN MILLIMETERS.
 3. INDEX AREA (PIN1 IDENTIFIER)

| | | | |
|-----------------------------|----------|---|----------------------|
| TOLERANCES UNLESS SPECIFIED | | www.IDT.com | |
| DECIMAL | ANGULAR | 6024 Silver Creek Valley Road San Jose, CA 95138 | |
| XX± | | PHONE: (408) 284-8200 | |
| XXXX± | | FAX: (408) 284-8591 | |
| APPROVALS | DATE | TITLE NR/NRG28 PACKAGE OUTLINE | |
| DRAWN <i>ymde</i> | 05/03/12 | 4.0 X 5.0 mm BODY - 0.85mm thick | |
| CHECKED | | 0.50 mm Pitch QFN (SAWN Type) | |
| | | SIZE | REV |
| | | C | 01 |
| DRAWING No. PSC-4418 | | | DO NOT SCALE DRAWING |
| | | | SHEET 1 OF 2 |

| REVISIONS | | | |
|-----------|---|----------|----------|
| REV | DESCRIPTION | DATE | APPROVED |
| 00 | INITIAL RELEASE | 02/28/13 | M. ROY |
| 01 | COMBINE POB & LAND PATTERN CHANGE PACKAGE THICKNESS | 5/13/13 | RC |

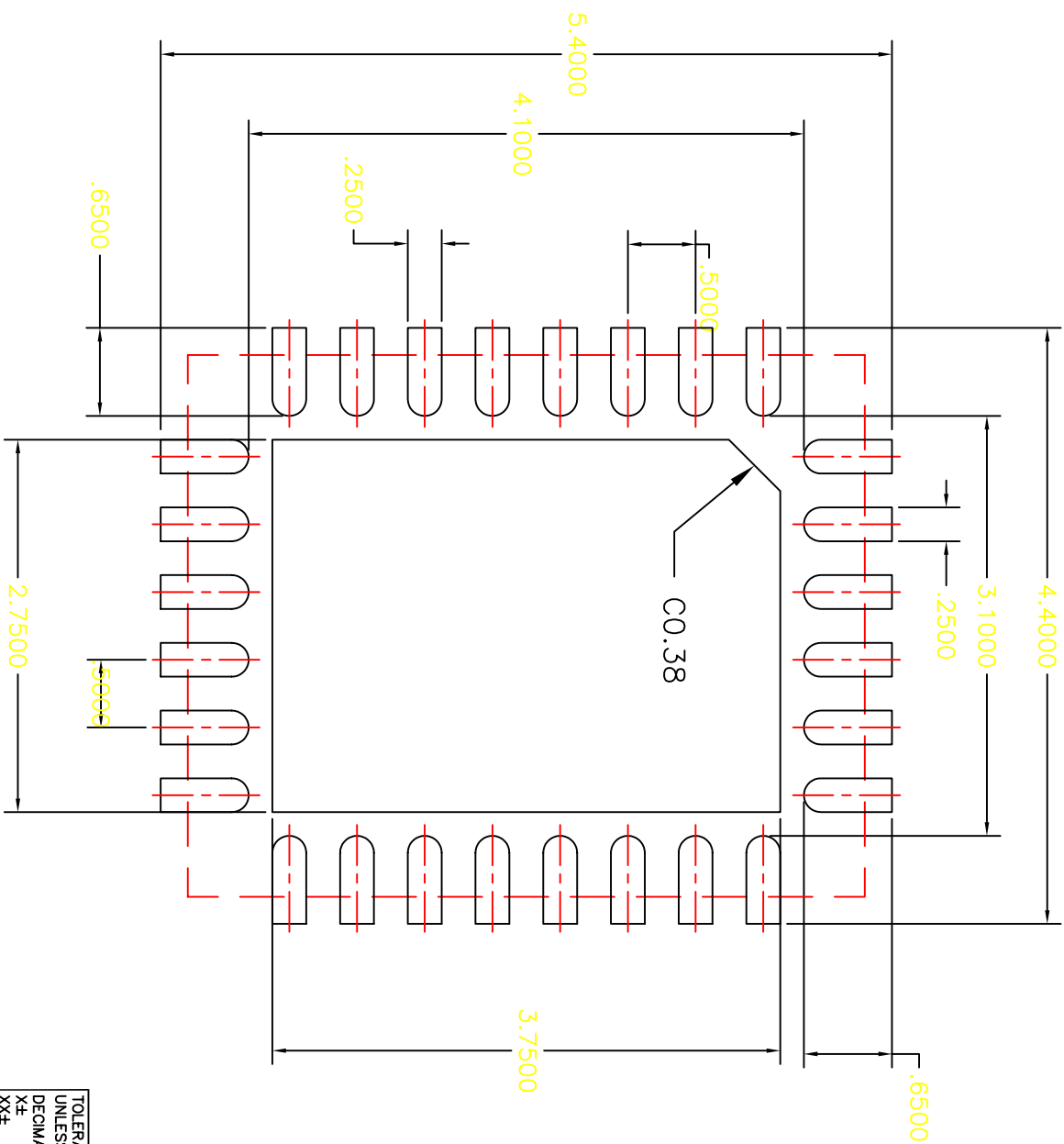

RECOMMENDED LAND PATTERN

| | | | |
|-----------------------------|---------|----------------------------------|--------------|
| TOLERANCES UNLESS SPECIFIED | | TITLE NR/NRG28 PACKAGE OUTLINE | |
| DECIMAL | ANGULAR | 4.0 X 5.0 mm BODY - 0.85mm thick | |
| XX+ | | 0.50 mm Pitch QFN (SAWN Type) | |
| XXX+ | | www.IDT.com | |
| APPROVALS | | DATE | |
| DRAWN | RDG | 02/28/13 | |
| CHECKED | | | |
| SIZE | | DRAWING No. | REV |
| C | | PSC-4418 | 01 |
| DO NOT SCALE DRAWING | | | SHEET 2 OF 2 |



6024 Silver Creek Valley Road
San Jose, CA 95138
PHONE: (408) 284-8200
FAX: (408) 284-8591